

**BROOKS BRIDGE WATER MAIN REPLACEMENT**  
for the  
Okaloosa Island Water Supply  
PROJECT

**BIDDING REQUIREMENTS  
AND  
CONTRACT DOCUMENTS**

Volume 1 of 2



**BID #: ITB WS 66-18**

**BID OPENS: SEPTEMBER 19, 2018 at 3:00 P.M.**

CH2M HILL  
Okaloosa County, FL  
August 2018



**TABLE OF CONTENTS****CONTRACTOR PROCUREMENT FRONT ENDS**

00 00 00	OCWS Contractor Procurement .....	1- 154
----------	-----------------------------------	--------

**TECHNICAL SPECIFICATIONS****DIVISION 1—GENERAL REQUIREMENTS**

01 11 00	Summary of Work.....	1- 1
01 29 00	Payment Procedures.....	1- 3
01 31 13	Project Coordination .....	1- 5
01 33 00	Submittal Procedures .....	1- 8
	Supplement 1, Forms: Transmittal of Contractor’s Submittal.	1- 1
01 42 13	Abbreviations and Acronyms .....	1- 5
01 50 00	Temporary Facilities and Controls.....	1- 10
	Supplement 1, PDCs for In-Water Activities .....	1- 3
	Supplement 2, Standard Manatee Conditions for In-Water Work .....	1- 1
	Supplement 3, Sea Turtle and Sawtooth Construction Conditions.....	1- 1
01 57 13	Temporary Erosion and Sediment Control .....	1- 6
01 77 00	Closeout Procedures.....	1- 4

**DIVISIONS 2 THROUGH 30 (NOT USED)****DIVISION 31—EARTHWORK**

31 23 23.15	Trench Backfill .....	1- 6
-------------	-----------------------	------

**DIVISION 32—EXTERIOR IMPROVEMENTS**

32 12 16	Asphalt Paving .....	1- 7
----------	----------------------	------

**DIVISION 33—UTILITIES**

33 05 01 02	Ductile Iron Pipe and Fitting.....	1- 8
33 05 01 10	High-Density Polyethylene Pressure Pipe and Fittings .....	1- 9
33 05 23.13	Utility Horizontal Directional Drilling .....	1- 4
	Supplement 1, 17-170 Brooks Bridge Report of Subsurface Exploration.....	1- 21
	Supplement 2, Brooks Bridge Water Main Replacement Project .....	1- 5

**DIVISIONS 34 THROUGH 49 (NOT USED)**

**DRAWINGS (BOUND SEPARATELY)**

**END OF SECTION**

# **BROOKS BRIDGE WATER MAIN REPLACEMENT**

for the  
Okaloosa Island Water Supply  
PROJECT

**Contractor Procurement Front Ends**



**BID #: ITB WS 66-18**

**BID OPENS: SEPTEMBER 19, 2018 at 3:00 P.M.**

**THIS PAGE WAS INTENTIONALLY LEFT BLANK**

**CONTENTS**

**Pages**

Invitation to Bid & Respondent’s Acknowledgement	
Notice to Respondents	
Bid Requirements	
General Services Bid Conditions	GSC-1
Drug-Free Workplace Certification	Form A
Conflict of Interest Disclosure Form	Form B
Federal E-Verify Compliance Certification	Form C
(Not Used)	Form D
Indemnification and Hold Harmless	Form E
Lobbying	Form F
Cone of Silence	Form G
Company Data	Form H
System of Awards Management	Form I
Addendum Acknowledgement	Form J
Bid Sheet	Form K
General Grant Funding Special Conditions “Exhibit B”	
Bid Bond	C430-1
Qualifications Statement	C451-1
Agreement	C520-1
Notice to Proceed	C550-1
Performance Bond	C610-1
Payment Bond	C615-1
Certificate of Attorney	00620-1
Contractor’s Application for Payment	C620-1
Certificate of Substantial Completion	C625-1
General Conditions	C700-1
Supplementary Conditions	C800-1
Change Order	C941-1

**THIS PAGE WAS INTENTIONALLY LEFT BLANK**





---

## INVITATION TO BID (ITB) & RESPONDENT'S ACKNOWLEDGEMENT

---

**ITB TITLE:**  
**OKALOOSA ISLAND WATER SUPPLY  
PROJECT - BROOKS BRIDGE WATER MAIN  
REPLACEMENT**

**ITB NUMBER:**  
**ITB WS 66-18**

---

**ISSUE DATE:** August 13, 2018, 3:00 P.M. CT  
**MANDATORY PRE-BID MEETING:** September 5, 2018, 10:00 A.M. CT  
**ITB OPENING DATE & TIME:** September 19, 2018, 3:00 P.M. CT  
**LAST DAY FOR QUESTIONS:** September 10, 2018, 5:00 P.M. CT

---

**NOTE: BIDS RECEIVED AFTER THE BID OPENING DATE & TIME WILL NOT BE CONSIDERED.**

---

Okaloosa County, Florida solicits your company to submit a bid on the above referenced goods or services. All terms, specifications and conditions set forth in this ITB are incorporated into your response. A bid will not be accepted unless all conditions have been met. All bids must have an authorized signature in the space provided below. All bids must be sealed and received by the Okaloosa County Clerk of Court by the "ITB Opening Date & Time" referenced above. The official clock for the purpose of receiving bids is located in the Clerk of Court, Brackin Building Conference & Training Room, #305 located at 302 N. Wilson St, Crestview, FL 32536. All envelopes containing sealed bids must reference the "ITB Title", "ITB Number" and the "ITB Opening Date & Time". Okaloosa County is not responsible for lost or late delivery of bids by the U.S. Postal Service or other delivery services used by the respondent. Neither faxed nor electronically submitted bids will be accepted. Bids may not be withdrawn for a period of ninety (90) days after the bid opening unless otherwise specified

---

**RESPONDENT ACKNOWLEDGEMENT FORM BELOW MUST BE COMPLETED, SIGNED, AND RETURNED AS PART OF YOUR BID. BIDS WILL NOT BE ACCEPTED WITHOUT THIS FORM, SIGNED BY AN AUTHORIZED AGENT OF THE RESPONDENT.**

COMPANY NAME \_\_\_\_\_

MAILING ADDRESS \_\_\_\_\_  
\_\_\_\_\_

CITY, STATE, ZIP \_\_\_\_\_

FEDERAL EMPLOYER'S IDENTIFICATION NUMBER (FEIN): \_\_\_\_\_

TELEPHONE NUMBER: \_\_\_\_\_ EXT: \_\_\_\_\_ FAX: \_\_\_\_\_

EMAIL: \_\_\_\_\_

---

I CERTIFY THAT THIS BID IS MADE WITHOUT PRIOR UNDERSTANDING, AGREEMENT, OR CONNECTION WITH ANY OTHER RESPONDENT SUBMITTING A BID FOR THE SAME MATERIALS, SUPPLIES, EQUIPMENT OR SERVICES, AND IS IN ALL RESPECTS FAIR AND WITHOUT COLLUSION OR FRAUD. I AGREE TO ABIDE BY ALL TERMS AND CONDITIONS OF THIS BID AND CERTIFY THAT I AM AUTHORIZED TO SIGN THIS BID FOR THE RESPONDENT.

AUTHORIZED SIGNATURE: \_\_\_\_\_ TYPED OR PRINTED NAME \_\_\_\_\_

TITLE: \_\_\_\_\_ DATE \_\_\_\_\_

---

**THIS PAGE WAS INTENTIONALLY LEFT BLANK**

**NOTICE TO RESPONDENTS**  
**ITB WS 66-18**

Notice is hereby given that the Board of County Commissioners of Okaloosa County, FL, will accept sealed bids until **September 19, 2018 at 3:00 P.M. CST** for **Okaloosa Island Water Supply Project - Brooks Bridge Water Main Replacement**.

Interested respondents desiring consideration shall provide an original and two (2) copies (total three (3)) of their Invitation to Bids (ITB) response with the respondent's areas of expertise identified. Submissions shall be portrait orientation, unbound, and 8 ½" x 11" where practical. **All originals must have original signatures in blue ink.**

The Notice to Respondents can be viewed at <https://www.bidnetdirect.com/florida> or at <http://www.co.okaloosa.fl.us/purchasing/home> then accessing the link "View Current Solicitations".

**At 10:00 A.M (CST), September 5, 2018, a mandatory pre-bid meeting will be held at Water and Sewer Administration Building, 3<sup>rd</sup> Floor located at 1804 Lewis Turner Blvd., Fort Walton, FL 32547 for all prospective bidders.**

**At 3:00 p.m. (CST), September 19, 2018, all bids will be opened and read aloud. All bids must be in sealed envelopes reflecting on the outside thereof the Respondent's name and "Okaloosa Island Water Supply Project - Brooks Bridge Water Main Replacement".** The Board of County Commissioners will consider all bids properly submitted at its scheduled bid opening in the **Conference & Training Room #305 (old First National Bank Bldg.)** located at 302 N. Wilson St, Crestview, FL 32536. Bids may be submitted in the Conference & Training Room #305 prior to bid opening or delivered to the Clerk of Circuit Court, 302 N. Wilson St., #203, Crestview, FL 32536. **NOTE: Crestview, FL is not a next day guaranteed delivery location by most delivery services.** Respondents using mail or delivery services assume all risks of late or non-delivery.

The County reserves the right to award the bid to the lowest responsive respondent and to waive any irregularity or technicality in bids received. Okaloosa County shall be the sole judge of the bid and the resulting agreement that is in its best interest and its decision shall be final.

Any Respondent failing to mark outside of the envelope as set forth herein may not be entitled to have their bid considered.

All bids should be addressed as follows:

**Okaloosa Island Water Supply Project - Brooks  
Bridge Water Main Replacement.**

Clerk of Circuit Court  
Newman C. Brackin Bldg.  
302 N. Wilson St. # 203  
Crestview, FL 32536

\_\_\_\_\_  
Jeff Hyde  
Purchasing Manager

\_\_\_\_\_  
Date

OKALOOSA COUNTY  
BOARD OF COUNTY COMMISSIONERS

Graham W. Fountain, Chairman

**THIS PAGE WAS INTENTIONALLY LEFT BLANK**

## **BID REQUIREMENTS**

**BID #: ITB WS 66-18**

**BID ITEM: OKALOOSA ISLAND WATER SUPPLY PROJECT for the construction of the Brooks Bridge Water Main Replacement**

### **SCOPE**

This contract includes the material, equipment, and labor services for BROOKS BRIDGE WATER MAIN REPLACEMENT specified herein. All materials shall be manufactured within the continental United States. No substitutions will be accepted unless approved by the Purchasing and the Water & Sewer Department. **Note: Evaluation of bid will be based on “TOTAL BASE BID AMOUNT”, and shall include itemized unit cost for identified items.**

Price shall be guaranteed for 90 days after the bids are read and received. Price shall include delivery of all equipment and appurtenances to the following location:

**1804 LEWIS TURNER BLVD. FORT WALTON BEACH, FL 32547**

OWNER Delivery Contact:

Mark Griffin, Okaloosa County Water & Sewer

850-651-7176 or [mgriffin@myokaloosa.com](mailto:mgriffin@myokaloosa.com)

Contractor is required to coordinate fabrication and shipping with the Vendor once a construction contract has been executed between the Board and a Contractor.

THE FOLLOWING MUST BE SUBMITTED WITH THE BID SOLICITATION:

- A list of any and all exceptions to the Contract Documents.
- Any additional information requested by the OWNER.

# **GENERAL SERVICES BID CONDITIONS**

## **1. PRE-BID ACTIVITY -**

**Addendum** - Except as provided in this section, respondents are prohibited from contacting or lobbying the County, County Administrator, Commissioners, County staff, and Review Committee members, or any other person authorized on behalf of the County related or involved with the solicitation. All inquiries on the scope of work, specifications, additional requirements, attachments, terms and general conditions or instructions, or any issue must be directed in writing, by US mail or email to:

DeRita Mason  
Contracts and Lease Coordinator  
Okaloosa County Purchasing Department  
5479A Old Bethel Road  
Crestview, FL 32536  
(850) 689-5960  
dmason@myokaloosa.com

All questions or inquiries must be received no later than the last day for questions (reference ITB & Respondent's Acknowledgement form). Any addenda or other modification to the bid documents will be issued by the County five (5) days prior to the date and time of bid closing, as written addenda, and will be posted to <http://www.bidnetdirect.com/florida> and the Okaloosa County website at <http://www.co.okaloosa.fl.us/purchasing/current-solicitations>.

Such written addenda or modification shall be part of the bid documents and shall be binding upon each respondent. Each respondent is required to acknowledge receipt of any and all addenda in writing and submit with their bid. No respondent may rely upon any verbal modification or interpretation.

## **2. PREPARATION OF BID** – The bid form is included with the bid documents. Additional copies may be obtained from the County. The respondent shall submit an original and two (2) copies {total three (3)} of the bid documents.

All blanks in the bid documents shall be completed by printing in ink or by typewriter in both words and numbers with the amounts extended, totaled and the bid signed. A bid price shall be indicated for each section, bid item, alternative, adjustment unit price item, and unit price item listed therein, or the words “No Bid”, “No Change”, or “Not Applicable” entered. No changes shall be made to the phraseology of the form or in the items mentioned therein. In case of any discrepancy between the written amount and the numerical figures, the written amount shall govern. Any bid which contains any omissions, erasures, alterations, additions, irregularities of any kind, or items not called for which shall in any manner fail to conform to the conditions of public notice inviting bids may be rejected.

A bid submitted by a partnership shall be executed in the partnership name and signed by a partner (whose title must appear under the signature). The official address of the partnership shall be shown below the signature.

A bid submitted by a limited liability company shall be executed in the name of the firm by a member and accompanied by evidence of authority to sign. The state of formation of the firm and the official address of the firm must be shown below the signature.

A bid submitted by an individual shall show the respondent's name and official address.

A bid submitted by a joint venture shall be executed by each joint venture in the manner indicated on the bid form. The official address of the joint venture must be shown below the signature.

It is preferred that all signatures be in blue ink with the names type or printed below the signature. Okaloosa County does not accept electronic signatures.

The bid shall contain an acknowledgement of receipt of all Addenda, the numbers of which shall be filled in on the form. The address and telephone # for communications regarding the bid shall be shown.

If the respondent is an out-of-state corporation, the bid shall contain evidence of respondent's authority and qualification to do business as an out-of-state corporation in the State of Florida. A state contractor license # for the State of Florida shall also be included on the bid form. Respondent shall be licensed in accordance with the requirements of Chapter 489, Florida Statutes.

- 3. INTEGRITY OF BID DOCUMENTS** - Respondents shall use the original Bid documents provided by the Purchasing Department and enter information only in the spaces where a response is requested. Respondents may use an attachment as an addendum to the Bid documents if sufficient space is not available. Any modifications or alterations to the original bid documents by the respondent, whether intentional or otherwise, will constitute grounds for rejection of a bid. Any such modification or alteration that a respondent wishes to propose must be clearly stated in the respondent's response in the form of an addendum to the original bid documents.
- 4. SUBMITTAL OF BID** – A bid shall be submitted no later than the date and time prescribed and at the place indicated in the advertisement or invitation to bid and shall be enclosed in an opaque sealed envelope plainly marked with the project title (and, if applicable, the designated portion of the project for which the bid is submitted), the name and address of the respondent, and shall be accompanied by the bid security and other required documents. It is the respondent's responsibility to assure that its bid is delivered at the proper time and place. Offers by telegram, facsimile, or telephone will **NOT** be accepted.

**Note: Crestview is not a next day delivery site for overnight carriers.**

- 5. MODIFICATION & WITHDRAWAL OF BID** - A bid may be modified or withdrawn by an appropriate document duly executed in the manner that a bid must be executed and delivered to the place where bids are to be submitted prior to the date and time for the opening of bids.

If within 24 hours after bids are opened any respondent files a duly signed written notice with the County and promptly thereafter demonstrates to the reasonable satisfaction of the County that there was a material substantial mistake in the preparation of its bid, that respondent may withdraw its bid, and the bid security may be returned. Thereafter, if the work is rebid, that respondent will be disqualified from 1) further bidding on the work, and 2) doing any work on the contract, either as a subcontractor or in any other capacity.

- 6. BIDS TO REMAIN SUBJECT TO ACCEPTANCE** – All bids will remain subject to acceptance or rejection for ninety (90) calendar days after the day of the bid opening, but the County may, in its sole discretion, release any bid and return the bid security prior to the end of this period.

**IDENTICAL TIE BIDS** - In case of identical procurement responses, the award shall be determined either by lot or on the basis of factors deemed to serve the interest of the County. In the case of the latter, there must be adequate documentation to support such a decision

- 7. CONDITIONAL & INCOMPLETE BIDS** - Okaloosa County specifically reserves the right to reject any conditional bid and bids which make it impossible to determine the true amount of the bid.
- 8. BID PRICE** – The bid price shall include all equipment, labor, materials, permit(s), freight, taxes, required insurance, Public Liability, Property Damage and Workers' Compensation, etc. to cover the finished work called for.
- 9. ADDITION/DELETION OF ITEM** – The County reserves the right to add or delete any item from this bid or resulting contract when deemed to be in the County's best interest.
- 10. SPECIFICATION EXCEPTIONS** – Specifications are based on the most current literature available. Respondent shall clearly list any change in the manufacturer's specifications which conflict with the bid specifications. Respondent must also explain any deviation from the bid specification in writing, as a foot note on the applicable bid page and enclose a copy of the manufacturer's specifications data detailing the changed item(s) with their bid. Failure of the respondent to comply with these provisions will result in respondents being held responsible for all costs required to bring the equipment in compliance with bid specifications.
- 11. APPLICABLE LAWS & REGULATIONS** – All applicable Federal and State laws, County and municipal ordinances, orders, rules and regulations of all authorities having



jurisdiction over the project shall apply to the bid throughout, and they will be deemed to be included in the contract the same as though they were written in full therein.

**12. DISQUALIFICATION OF RESPONDENTS** - Any of the following reasons may be considered as sufficient for the disqualification of a respondent and the rejection of its bid:

- a. Submission of more than one proposal for the same work from an individual, firm or corporation under the same or different name.
- b. Evidence that the respondent has a financial interest in the firm of another respondent for the same work.
- c. Evidence of collusion among respondents. Participants in such collusion will receive no recognition as respondents for any future work of the County until such participant has been reinstated as a qualified respondent.
- d. Uncompleted work which in the judgment of the County might hinder or prevent the prompt completion of additional work if awarded.
- e. Failure to pay or satisfactorily settle all bills due for labor and material on former contracts in force at the time of advertisement of proposals.
- f. Default under previous contract.
- g. Listing of the respondent by the Federal, Local and State Government on its barred/suspended vendor list.

**13. AWARD OF BID**

- A. **Okaloosa County Review** - Okaloosa County designated Staff will review all bids and will participate in the Recommendation to Award.
- B. The County will award the bid to the lowest respondent, and the County reserves the right to award the bid to the respondent submitting a responsive bid with a resulting negotiated agreement which is most advantageous and in the best interest of the County, and to reject any and all bids or to waive any irregularity or technicality in bids received. Okaloosa County shall be the sole judge of the bid and the resulting negotiated agreement that is in its best interest and its decision shall be final.
- C. Okaloosa County reserves the right to waive any informalities or reject any and all bids, in whole or part, to utilize any applicable state contracts in lieu of or in addition to this bid and to accept the bid that in its judgment will best serve the interest of the County.

- D. Okaloosa County specifically reserves the right to reject any conditional bids and will normally reject those which made it impossible to determine the true amount of the bid. Each item must be bid separately and no attempt is to be made to tie any item or items to any other item or items.
- 14. WARRANTY** – (The warranty will be in the name of Okaloosa County) Warranty work specified herein is for defects in materials and in labor and workmanship. State the manufacturer’s warranty with your bid.
- 15. PAYMENTS** – The respondent shall be paid upon submission of invoices and approval of acceptance by Okaloosa County Board of County Commissioners, Finance Office, 302 N. Wilson St., #203, Crestview FL 32536, for the prices stipulated herein for articles delivered and accepted. Invoices must show Contract #.
- 16. DISCRIMINATION** - An entity or affiliate who has been placed on the discriminatory vendor list may not submit a bid on a contract to provide goods or services to a public entity, may not submit a bid on a contract with a public entity for the construction or repair of a public building or public work, may not submit bids on leases of real property to a public entity, may not award or perform work as a contractor, supplier, subcontractor, or consultant under contract with any public entity, and may not transact business with any public entity.
- 17. PUBLIC ENTITY CRIME INFORMATION** - {PRIVATE }Pursuant to Florida Statute 119.071 (1)(b).2, a respondent may not be awarded or perform work as a contractor, supplier, subcontractor, or consultant under a contract with any public entity; and may not transact business with any public entity in excess of the threshold amount provided in s. [287.017](#) for CATEGORY TWO for a period of 36 months following the date of being placed on the convicted vendor list.
- 18. CONFLICT OF INTEREST** - The award hereunder is subject to the provisions of Chapter 112, Florida Statutes. All respondents must disclose with their bids the name of any officer, director, or agent who is also a public officer or an employee of the Okaloosa Board of County Commissioners, or any of its agencies. Furthermore, all respondents must disclose the name of any County officer or employee who owns, directly or indirectly, an interest of five percent (5%) or more in the firm or any of its branches.
- Note: For respondent’s convenience, this certification form is enclosed and is made a part of the bid package.**
- 19. REORGANIZATION OR BANKRUPTCY PROCEEDINGS** – Bids will not be considered from respondents who are currently involved in official financial reorganization or bankruptcy proceedings.
- 20. INVESTIGATION OF RESPONDENT** – The County may make such investigations, as it deems necessary to determine the stability of the respondent to perform the work and that there is no conflict of interest as it relates to the project. The respondent shall furnish to the

Owner any additional information and financial data for this purpose as the County may request.

- 21. CONE OF SILENCE** - The Okaloosa County Board of County Commissioners has established a solicitation silence policy (**Cone of Silence**) that prohibits oral and written communication regarding all formal solicitations for goods and services (formal proposals, Request for Proposals, Requests for Qualifications) issued by the Board through the County Purchasing Department. The period commences from the date of advertisement until award of contract.

**Note: For respondent's convenience, this certification form is enclosed and is made a part of the bid package.**

- 22. REVIEW OF PROCUREMENT DOCUMENTS** - Per Florida Statute 119.071 (2) 2 sealed bids, proposals, or replies received by the County pursuant to a competitive solicitation are exempt from public disclosure until such time as the County provides notice of an intended decision or until 30 days after opening the bids, proposals, or final replies, whichever is earlier.

- 23. COMPLIANCE WITH FLORIDA STATUTE 119.0701** - The Respondent shall comply with all the provisions of section 119.0701, Florida Statutes relating to the public records which requires, among other things, that the Respondent: (a) Keep and maintain public records; (b) Provide the public with access to public records on the same terms and conditions that the public agency would provide the records; (c) ensure that public records that are exempt or confidential and exempt from public records disclosure requirements are not disclosed except as authorized by law; and (d) Meet all requirements for retaining public records and transfer, at no cost, to the public agency all public records in possession of the respondent upon termination of the contract.

- 24. PROTECTION OF RESIDENT WORKERS** – The Okaloosa County Board of County Commissioners actively supports the Immigration and Nationality Act (INA) which includes provisions addressing employment eligibility, employment verifications, and nondiscrimination. Under the INA, employers may hire only persons who may legally work in the United States (i.e., citizens and nationals of the U.S.) and aliens authorized to work in the U.S. The employer must verify the identity and employment eligibility of anyone to be hired, which includes completing the Employment Eligibility Verifications. The respondent shall establish appropriate procedures and controls so no services or products under the Contract Documents will be performed or manufactured by any worker who is not legally eligible to perform such services or employment. Okaloosa County reserves the right to request documentation showing compliance with the requirements.

Respondents doing construction business with Okaloosa County are required to use the Federal Government Department of Homeland Security's website and use the E-Verify Employment Eligibility Verifications System to confirm eligibility of all employees to work in the United States.

**25. SUSPENSION OR TERMINATION FOR CONVENIENCE** - The County may, at any time, without cause, order Respondent in writing to suspend, delay or interrupt the work in whole or in part for such period of time as the County may determine, or to terminate all or a portion of the Contract for the County's convenience. Upon such termination, the Contract Price earned to the date of termination shall be paid to Respondent, but Respondent waives any claim for damages, including loss of profits arising out of or related to the early termination. Those Contract provisions which by their nature survive final acceptance shall remain in full force and effect. If the County orders a suspension, the Contract price and Contract time may be adjusted for increases in the cost and time caused by suspension, delay or interruption. No adjustment shall be made to the extent that performance is, was or would have been so suspended, delayed or interrupted by reason for which Respondent is responsible; or that an equitable adjustment is made or denied under another provision of this Contract.

**26. FAILURE OF PERFORMANCE/DELIVERY** - In case of default by the respondent, the County after due notice (oral or written) may procure the necessary supplies or services from other sources and hold the respondent responsible for difference in cost incurred. Continuous instances of default shall result in cancellation of the award and removal of the respondent from the bid list for duration of one (1) year, at the option of the County.

**27. AUDIT** - Respondent shall permit the County or an authorized, independent audit agency to inspect all data and records of respondent relating to its performance and its subcontracts under this bid from the date of the award through and until the expiration of contract.

**28. EQUAL EMPLOYMENT OPPORTUNITY; NON DISCRIMINATION** – Respondent will not discriminate against any employee or an applicant for employment because of race, color, religion, gender, sexual orientation, national origin, age, familial status or handicap.

**29. NON-COLLUSION** – Respondent certifies that it has entered into no agreement to commit a fraudulent, deceitful, unlawful or wrongful act, or any act which may result in an unfair advantage over other respondents. See Florida Statute 838.22.

**30. UNAUTHORIZED ALIENS/PATRIOT'S ACT** – The knowing employment by respondent or its subcontractors of any alien not authorized to work by the immigration laws is prohibited and shall be a default of the contract. In the event that the respondent is notified or becomes aware of such default, the respondent shall take steps as are necessary to terminate said employment with 24 hours of notification or actual knowledge that an alien is being employed. Respondent's failure to take such steps as are necessary to terminate the employment of any said alien within 24 hours of notification or actual knowledge that an alien is being employed shall be grounds for immediate termination of the contract. Respondent shall take all commercially reasonable precautions to ensure that it and its subcontractors do not employ persons who are not authorized to work by the immigration laws.

**31. The following documents are to be submitted with the proposal packet:**

- A.** Exhibit “B” General Grant Funding Special Provisions
- B.** Standard Additional Clauses “Exhibit C”
- C.** Drug-Free Workplace Certification Form
- D.** Conflict of Interest
- E.** Federal E-Verify
- F.** Indemnification and Hold Harmless
- G.** Certification Regarding Lobbying Proposal Sheet
- H.** Cone of Silence
- I.** Company Data
- J.** Systems of Award Management
- K.** Addendum Acknowledgement

## EXHIBIT B

### GENERAL GRANT FUNDING SPECIAL PROPOSAL CONDITIONS

Either this solicitation is fully or partially Grant funded. Respondents shall comply with the clauses as enumerated below.

1. **Drug Free Workplace Requirements:** Drug-free workplace requirements in accordance with Drug Free Workplace Act of 1988 (Pub l 100-690, Title V, Subtitle D) All contractors entering into Federal funded contracts over \$100,000 must comply with Federal Drug Free workplace requirements as Drug Free Workplace Act of 1988.
2. **Contractor Compliance:** The contractor shall comply with all uniform administrative requirements, cost principles, and audit requirements for federal awards.
3. **Conflict of Interest:** The contractor must disclose in writing any potential conflict of interest to the County or pass-through entity in accordance with applicable Federal policy.
4. **Mandatory Disclosures:** The contractor must disclose in writing all violations of Federal criminal law involving fraud, bribery, or gratuity violations potentially affecting the Federal award.
5. **Utilization of Minority and Women Firms (M/WBE):** The contractor must take all necessary affirmative steps to assure that minority businesses, women's business enterprises, and labor surplus area firms are used when possible, in accordance with 2CFR 200.321. If subcontracts are to be let, prime contractor will require compliance by all sub-contractors. Prior to contract award, the contractor shall document efforts to utilize M/WBE firms including what firms were solicited as suppliers and/or subcontractors as applicable and submit this information with their bid submittal. Information regarding certified M/WBE firms can be obtained from:  
  
Florida Department of Management Services (Office of Supplier Diversity)  
  
Florida Department of Transportation  
  
Minority Business Development Center in most large cities and  
  
Local Government M/DBE programs in many large counties and cities
6. **Equal Employment Opportunity:** (As per Executive Order 11246) The contractor may not discriminate against any employee or applicant for employment because of age, race, color, creed, sex, disability or national origin. The contractor agrees to take affirmative action to ensure that applicants are employed and that employees are treated during employment without regard to their age, race, color, creed, sex, disability or national origin. Such action shall include but not be limited to the following: employment, upgrading, demotion or transfer, recruitment advertising, layoff or termination, rates of pay or other forms of compensation and selection for training including apprenticeship.
7. **Davis-Bacon Act:** If applicable to this contract, the contractor agrees to comply with all provisions of the Davis Bacon Act as amended (40 U.S.C. 3141-3148). Contractors are required to pay wages to laborers and mechanics at a rate not less than the prevailing wages specified in a wage determination made by the Secretary of Labor. In addition, contractors must be required to pay wages not less than once a week. If the grant award contains Davis Bacon provisions, the County will place a copy of the current prevailing wage determination issued by the Department of Labor in the solicitation document. The decision to award a contract shall be conditioned upon the acceptance of the wage determination.

8. **Copeland Anti Kick Back Act**: If applicable to this contract, contractors shall comply with all the requirements of 18 U.S.C. § 874, 40 U.S.C. § 3145, 29 CFR Part 3 which are incorporated by reference to this contract. Contractors are prohibited from inducing by any means any person employed in the construction, completion or repair of public work to give up any part of the compensation to which he or she is otherwise entitled.
9. **Contract Work Hours and Safety Standards Act** (40 U.S.C. 3701–3708): Where applicable, all contracts awarded in excess of \$100,000 that involve the employment of mechanics or laborers must be in compliance with 40 U.S.C. 3702 and 3704, as supplemented by Department of Labor regulations (29 CFR Part 5). Under 40 U.S.C. 3702 of the Act, each contractor is required to compute the wages of every mechanic and laborer on the basis of a standard work week of 40 hours. Work in excess of the standard work week is permissible provided that the worker is compensated at a rate of not less than one and a half times the basic rate of pay for all hours worked in excess of 40 hours in the work week. The requirements of 40 U.S.C. 3704 are applicable to construction work and provide that no laborer or mechanic must be required to work in surroundings or under working conditions which are unsanitary, hazardous or dangerous. These requirements do not apply to the purchases of supplies or materials or articles ordinarily available on the open market, or contracts for transportation or transmission of intelligence.
10. **Clean Air Act (42 U.S.C. 7401–7671q.)** and the Federal Water Pollution Control Act (33 U.S.C. 1251–1387): as amended—The Contractor agrees to comply with all applicable standards, orders or regulations issued pursuant to the Clean Air Act (42 U.S.C. 7401–7671q) and the Federal Water Pollution Control Act as amended (33 U.S.C. 1251–1387). Violations must be reported to the Federal awarding agency and the Regional Office of the Environmental Protection Agency (EPA).
11. **Debarment and Suspension** (Executive Orders 12549 and 12689): A contract award (see 2 CFR 180.220) must not be made to parties listed on the government wide exclusions in the System for Award Management (SAM), in accordance with the OMB guidelines at 2 CFR 180 that implement Executive Orders 12549 (3 CFR part 1986 Comp., p. 189) and 12689 (3 CFR part 1989 Comp., p. 235), “Debarment and Suspension. SAM Exclusions contains the names of parties debarred, suspended, or otherwise excluded by agencies, as well as parties declared ineligible under statutory or regulatory authority other than Executive Order 12549. The contractor shall certify compliance. The bidder or proposer further agrees to include a provision requiring such compliance in its lower tier covered transactions and subcontracts.
12. **Byrd Anti-Lobbying Amendment** (31 U.S.C. 1352): Contractors that apply or bid for an award exceeding \$100,000 must file the required certification. Each tier certifies to the tier above that it will not and has not used Federal appropriated funds to pay any person or organization for influencing or attempting to influence an officer or employee of any agency, a member of Congress, officer or employee of Congress, or an employee of a member of Congress in connection with obtaining any Federal contract, grant or any other award covered by 31 U.S.C. 1352. Each tier must also disclose any lobbying with non-Federal funds that takes place in connection with obtaining any Federal award. Such disclosures are forwarded from tier to tier up to the non-Federal award. The contractor shall certify compliance.

13. **Rights to Inventions Made Under a Contract or Agreement:** If the Federal award meets the definition of “funding agreement” under 37 CFR § 401.2 (a) and the recipient or subrecipient wishes to enter into a contract with a small business firm or nonprofit organization regarding the substitution of parties, assignment or performance of experimental, developmental, or research work under that “funding agreement,” the recipient or subrecipient must comply with the requirements of 37 CFR Part 401, “ Rights to Inventions Made by Nonprofit Organizations and Small Business Firms Under Government Grants, Contracts and Cooperative Agreements,” and any implementing regulations issued by the awarding agency.

14. **Procurement of Recovered Materials:** Contractors must comply with section 6002 of the Solid Waste Disposal Act, as amended by the Resource Conservation and Recovery Act. The requirements of Section 6002 include procuring only items designated in guidelines of the Environmental Protection Agency (EPA) at 40 CFR part 247 that contain the highest percentage of recovered materials practicable, consistent with maintaining a satisfactory level of competition, where the purchase price of the item exceeds \$10,000 or the value of the quantity acquired during the preceding fiscal year exceeded \$10,000; procuring solid waste management services in a manner that maximizes energy and resource recovery; and establishing an affirmative procurement program for procurement of recovered materials identified in the EPA guidelines.

15. **Access to Records and Reports:**

Contractor will make available to the County’s granting agency, the granting agency’s Office of Inspector General, the Government Accountability Office, the Comptroller General of the United States, Okaloosa County, Okaloosa County Clerk of Court’s Inspector General, or any of their duly authorized representatives any books, documents, papers or other records, including electronic records, of the contractor that are pertinent to the County’s grant award, in order to make audits, investigations, examinations, excerpts, transcripts, and copies of such documents. The right also includes timely and reasonable access to the contractor’s personnel during normal business hours for the purpose of interview and discussion related to such documents. This right of access shall continue as long as records are retained.

16. **Record Retention:**

Contractor will retain of all required records pertinent to this contract for a period of three years, beginning on a date as described in 2 C.F.R. §200.333 and retained in compliance with 2 C.F.R. §200.333.

17. **Federal Changes:** Contractor shall comply with all applicable Federal agency regulations, policies, procedures and directives, including without limitation those listed directly or by reference, as they may be amended or promulgated from time to time during the term of the contract.

18. **Termination for Default (Breach or Cause):**

Contracts in excess of \$10,000 – If Contractor does not deliver supplies in accordance with the contract delivery schedule, or, if the contract is for services, the Contractor fails to perform in the manner called for in the contract, or if the Contractor fails to comply with any other provisions of the contract, the County may terminate the contract for default. Termination shall be effected by serving a notice of termination on the contractor setting forth the manner in which the Contractor is in default. The contractor will only be paid the contract price for supplies delivered and accepted, or services performed in accordance with the manner of performance set forth in the contract.



19. **Safeguarding Personal Identifiable Information**

Contractor will take reasonable measures to safeguard protected personally identifiable information and other information designated as sensitive by the awarding agency or is considered sensitive consistent with applicable Federal, state and/or local laws regarding privacy and obligations of confidentiality.

20. **Prohibition on utilization of cost plus a percentage of cost contracts:** The County will not award contracts containing Federal funding on a cost plus percentage of cost basis.

21. **Prohibition on utilization of time and material type contracts:** The County will not award contracts based on a time and material basis if the contract contains Federal funding.

22. **Disputes:** Any dispute arising under this Agreement which is not settled by Agreement of the parties may be settled by mediation, arbitration, or other appropriate legal proceedings. Pending any decision, appeal or judgment in such proceedings or the settlement of any dispute arising under this Agreement, shall proceed diligently with the performance of this Agreement in accordance with the decision of the County. This Agreement shall be construed under the laws of the State of Florida, and venue for any actions arising out of this Agreement shall be in the Circuit Court of Okaloosa County.

23. **Energy Policy and Conservation Act (43 U.S.C.§6201)**

All contracts except micro-purchases (\$3000 or less, except for construction contracts over \$2000). Contracts shall comply with mandatory standards and policies relating to energy efficiency, stating in the state energy conservation plan issued in compliance with the Energy Policy and Conservation act. (Pub. L. 94-163, 89 Stat. 871) [53 FR 8078, 8087, Mar. 11, 1988, as amended at 60 FR 19639, 19645, Apr. 19, 1995].

---

---

As the person authorized to sign this statement, I certify that this company complies/will comply fully with the above requirements.

DATE: \_\_\_\_\_

SIGNATURE: \_\_\_\_\_

COMPANY: \_\_\_\_\_

NAME: \_\_\_\_\_

ADDRESS: \_\_\_\_\_

TITLE: \_\_\_\_\_

\_\_\_\_\_

\_\_\_\_\_

E-MAIL: \_\_\_\_\_

PHONE NO.: \_\_\_\_\_

Exhibit "C"

Standard Contract Clauses

**Title VI Clauses for Compliance with Nondiscrimination Requirements**

**Compliance with Nondiscrimination Requirements**

During the performance of this contract, the contractor, for itself, its assignees, and successors in interest (hereinafter referred to as the "contractor") agrees as follows:

1. **Compliance with Regulations:** The contractor (hereinafter includes consultants) will comply with the Title VI List of Pertinent Nondiscrimination Acts And Authorities, as they may be amended from time to time, which are herein incorporated by reference and made a part of this contract.
2. **Non-discrimination:** The contractor, with regard to the work performed by it during the contract, will not discriminate on the grounds of race, color, or national origin in the selection and retention of subcontractors, including procurements of materials and leases of equipment. The contractor will not participate directly or indirectly in the discrimination prohibited by the Nondiscrimination Acts and Authorities, including employment practices when the contract covers any activity, project, or program set forth in Appendix B of 49 CFR part 21.
3. **Solicitations for Subcontracts, Including Procurements of Materials and Equipment:** In all solicitations, either by competitive bidding, or negotiation made by the contractor for work to be performed under a subcontract, including procurements of materials, or leases of equipment, each potential subcontractor or supplier will be notified by the contractor of the contractor's obligations under this contract and the Nondiscrimination Acts And Authorities on the grounds of race, color, or national origin.
4. **Information and Reports:** The contractor will provide all information and reports required by the Acts, the Regulations, and directives issued pursuant thereto and will permit access to its books, records, accounts, other sources of information, and its facilities as may be determined by the sponsor or the Federal Aviation Administration to be pertinent to ascertain compliance with such Nondiscrimination Acts And Authorities and instructions. Where any information required of a contractor is in the exclusive possession of another who fails or refuses to furnish the information, the contractor will so certify to the sponsor or the Federal Aviation Administration, as appropriate, and will set forth what efforts it has made to obtain the information.
5. **Sanctions for Noncompliance:** In the event of a contractor's noncompliance with the Non-discrimination provisions of this contract, the sponsor will impose such contract sanctions as it or the Federal Aviation Administration may determine to be appropriate, including, but not limited to:

- a. Withholding payments to the contractor under the contract until the contractor complies; and/or
  - b. Cancelling, terminating, or suspending a contract, in whole or in part.
6. **Incorporation of Provisions:** The contractor will include the provisions of paragraphs one through six in every subcontract, including procurements of materials and leases of equipment, unless exempt by the Acts, the Regulations and directives issued pursuant thereto. The contractor will take action with respect to any subcontract or procurement as the sponsor or the Federal Aviation Administration may direct as a means of enforcing such provisions including sanctions for noncompliance. Provided, that if the contractor becomes involved in, or is threatened with litigation by a subcontractor, or supplier because of such direction, the contractor may request the sponsor to enter into any litigation to protect the interests of the sponsor. In addition, the contractor may request the United States to enter into the litigation to protect the interests of the United States.

## **Title VI List of Pertinent Nondiscrimination Acts and Authorities**

### **Title VI List of Pertinent Nondiscrimination Acts and Authorities**

During the performance of this contract, the contractor, for itself, its assignees, and successors in interest (hereinafter referred to as the “contractor”) agrees to comply with the following non-discrimination statutes and authorities; including but not limited to:

- Title VI of the Civil Rights Act of 1964 (42 U.S.C. § 2000d *et seq.*, 78 stat. 252), (prohibits discrimination on the basis of race, color, national origin);
- 49 CFR part 21 (Non-discrimination In Federally-Assisted Programs of The Department of Transportation—Effectuation of Title VI of The Civil Rights Act of 1964);
- The Uniform Relocation Assistance and Real Property Acquisition Policies Act of 1970, (42 U.S.C. § 4601), (prohibits unfair treatment of persons displaced or whose property has been acquired because of Federal or Federal-aid programs and projects);
- Section 504 of the Rehabilitation Act of 1973, (29 U.S.C. § 794 *et seq.*), as amended, (prohibits discrimination on the basis of disability); and 49 CFR part 27;
- The Age Discrimination Act of 1975, as amended, (42 U.S.C. § 6101 *et seq.*), (prohibits discrimination on the basis of age);
- Airport and Airway Improvement Act of 1982, (49 USC § 471, Section 47123), as amended, (prohibits discrimination based on race, creed, color, national origin, or sex);
- The Civil Rights Restoration Act of 1987, (PL 100-209), (Broadened the scope, coverage and applicability of Title VI of the Civil Rights Act of 1964, The Age Discrimination Act of 1975 and Section 504 of the Rehabilitation Act of 1973, by expanding the definition of

the terms “programs or activities” to include all of the programs or activities of the Federal-aid recipients, sub-recipients and contractors, whether such programs or activities are Federally funded or not);

- Titles II and III of the Americans with Disabilities Act of 1990, which prohibit discrimination on the basis of disability in the operation of public entities, public and private transportation systems, places of public accommodation, and certain testing entities (42 U.S.C. §§ 12131 – 12189) as implemented by Department of Transportation regulations at 49 CFR parts 37 and 38;
- The Federal Aviation Administration’s Non-discrimination statute (49 U.S.C. § 47123) (prohibits discrimination on the basis of race, color, national origin, and sex);
- Executive Order 12898, Federal Actions to Address Environmental Justice in Minority Populations and Low-Income Populations, which ensures non-discrimination against minority populations by discouraging programs, policies, and activities with disproportionately high and adverse human health or environmental effects on minority and low-income populations;
- Executive Order 13166, Improving Access to Services for Persons with Limited English Proficiency, and resulting agency guidance, national origin discrimination includes discrimination because of limited English proficiency (LEP). To ensure compliance with Title VI, you must take reasonable steps to ensure that LEP persons have meaningful access to your programs (70 Fed. Reg. at 74087 to 74100);
- Title IX of the Education Amendments of 1972, as amended, which prohibits you from discriminating because of sex in education programs or activities (20 U.S.C. 1681 et seq).

### **FEDERAL FAIR LABOR STANDARDS ACT (FEDERAL MINIMUM WAGE)**

All contracts and subcontracts that result from this solicitation incorporate by reference the provisions of 29 CFR part 201, the Federal Fair Labor Standards Act (FLSA), with the same force and effect as if given in full text. The FLSA sets minimum wage, overtime pay, recordkeeping, and child labor standards for full and part time workers.

The [*contractor / consultant*] has full responsibility to monitor compliance to the referenced statute or regulation. The [*contractor / consultant*] must address any claims or disputes that arise from this requirement directly with the U.S. Department of Labor – Wage and Hour Division

### **OCCUPATIONAL SAFETY AND HEALTH ACT OF 1970**

All contracts and subcontracts that result from this solicitation incorporate by reference the requirements of 29 CFR Part 1910 with the same force and effect as if given in full text.

Contractor must provide a work environment that is free from recognized hazards that may cause death or serious physical harm to the employee. The Contractor retains full responsibility to monitor its compliance and their subcontractor's compliance with the applicable requirements of the Occupational Safety and Health Act of 1970 (20 CFR Part 1910). Contractor must address any claims or disputes that pertain to a referenced requirement directly with the U.S. Department of Labor – Occupational Safety and Health Administration.

### **E-VERIFY**

Enrollment and verification requirements.

- (1) If the Contractor is not enrolled as a Federal Contractor in E-Verify at time of contract award, the Contractor shall-
  - a. Enroll. Enroll as a Federal Contractor in the E-Verify Program within thirty (30) calendar days of contract award;
  - b. Verify all new employees. Within ninety (90) calendar days of enrollment in the E-Verify program, begin to use E-Verify to initiate verification of employment eligibility of all new hires of the Contractor, who are working in the United States, whether or not assigned to the contract, within three (3) business days after the date of hire (but see paragraph (b)(3) of this section); and,
  - c. Verify employees assigned to the contract. For each employee assigned to the contract, initiate verification within ninety (90) calendar days after date of enrollment or within thirty (30) calendar days of the employee's assignment to the contract, whichever date is later (but see paragraph (b)(4) of this section.)
- (2) If the Contractor is enrolled as a Federal Contractor in E-Verify at time of contract award, the Contractor shall use E-Verify to initiate verification of employment eligibility of
  - a. All new employees.
    - i. Enrolled ninety (90) calendar days or more. The Contractor shall initiate verification of all new hires of the Contractor, who are working in the United States, whether or not assigned to the contract, within three (3) business days after the date of hire (but see paragraph (b)(3) of this section); or
    - b. Enrolled less than ninety (90) calendar days. Within ninety (90) calendar days after enrollment as a Federal Contractor in E-Verify, the Contractor shall initiate verification of all new hires of the contractor, who are working in the United States, whether or not assigned to the contract, within three (3)

business days after the date of hire (but see paragraph (b)(3) of this section;  
or

ii. Employees assigned to the contract. For each employee assigned to the contract, the Contractor shall initiate verification within ninety (90) calendar days after date of contract award or within thirty (30) days after assignment to the contract, whichever date is later (but see paragraph (b)(4) of this section.)

- (3) If the Contractor is an institution of higher education (as defined at 20 U.S.C. 1001(a)); a State of local government or the government of a Federally recognized Indian tribe, or a surety performing under a takeover agreement entered into with a Federal agency pursuant to a performance bond, the Contractor may choose to verify only employees assigned to the contract, whether existing employees or new hires. The Contractor shall follow the applicable verification requirements of (b)(1) or (b)(2), respectively, except that any requirement for verification of new employees applies only to new employees assigned to the contract.
- (4) Option to verify employment eligibility of all employees. The Contractor may elect to verify all existing employees hired after November 6, 1986 (after November 27, 2009, in the Commonwealth of the Northern Mariana Islands), rather than just those employees assigned to the contract. The Contractor shall initiate verification for each existing employee working in the United States who was hired after November 6, 1986 (after November 27, 2009, in the Commonwealth of the Northern Mariana Islands), within one hundred eighty (180) calendar days of-
- i. Enrollment in the E-Verify program; or
  - ii. Notification to E-Verify Operations of the Contractor's decision to exercise this option, using the contract information provided in the E-Verify program Memorandum of Understanding (MOU)
- (5) The Contractor shall comply, for the period of performance of this contract, with the requirements of the E-Verify program MOU.
- i. The Department of Homeland Security (DHS) or the Social Security Administration (SSA) may terminate the Contractor's MOU and deny access to the E-Verify system in accordance with the terms of the MOU. In such case, the Contractor, will be referred to a suspension or debarment official.
  - ii. During the period between termination of the MOU and a decision by the suspension or debarment official whether to suspend or debar, the contractor is excused from its obligations under paragraph (b) of this clause. If the suspension or debarment official determines not to suspend or debar the Contractor, then the Contractor must reenroll in E-Verify.

iii. Web site. Information on registration for and use of the E-Verify program can be obtained via the Internet at the Department of Homeland Security Web site: <http://www.dhs.gov/E-Verify>.

Individuals previously verified. The Contractor is not required by this clause to perform additional employment verification using E-Verify for any employee-

- (a) Whose employment eligibility was previously verified by the Contractor through the E-Verify program;
- (b) Who has been granted and holds an active U.S. Government security clearance for access to confidential, secret, or top secret information in accordance with the National Industrial Security Program Operating Manual; or
- (c) Who has undergone a completed background investigation and been issued credentials pursuant to Homeland Security Presidential Directive (HSPD)-12. Policy for a Common Identification Standard for Federal Employees and Contractors.

Subcontracts. The Contractor shall include the requirements of this clause, including this paragraph (appropriately modified for identification of the parties in each subcontract that-

- (1) Is for-(i) Commercial and noncommercial services (except for commercial services that are part of the purchase of a COTS item (or an item that would be a COTS item, but for minor modifications), performed by the COTS provider, and are normally provided for that COTS item); or
  - (ii) Construction;
- (2) Has a value of more than \$3,500; and
- (3) Includes work performed in the United States.

**THIS PAGE WAS INTENTIONALLY LEFT BLANK**



# **DRUG-FREE WORKPLACE CERTIFICATION**

THE BELOW SIGNED RESPONDENT CERTIFIES that it has implemented a drug-free workplace program. In order to have a drug-free workplace program, a business shall:

1. Publish a statement notifying employees that the unlawful manufacture, distribution, dispensing, possession, or use of a controlled substance is prohibited in the workplace and specifying the actions that will be taken against employees for violations of such prohibition.
2. Inform employees about the dangers of drug abuse in the workplace, the business's policy of maintaining a drug-free workplace, any available drug counseling, rehabilitation and employee assistance programs, and the penalties that may be imposed upon employees for drug abuse violations.
3. Give each employee engaged in providing the commodities or contractual services that are under quote a copy of the statement specified in subsection 1.
4. In the statement specified in subsection 1, notify the employees that, as a condition of working on the commodities or contractual services that are under quote, the employee will abide by the terms of the statement and will notify the employer of any conviction of, or plea of guilty or nolo contendere to, any violation of Chapter 893, Florida Statutes, or of any controlled substance law of the United States or any state, for a violation occurring in the workplace no later than five (5) days after such conviction.
5. Impose a sanction on, or require the satisfactory participation in, drug abuse assistance or rehabilitation program if such is available in employee's community, by any employee who is convicted.
6. Make a good faith effort to continue to maintain a drug-free workplace through implementation of this section.

As the person authorized to sign this statement, I certify that this firm complies fully with the above requirements.

DATE: \_\_\_\_\_

SIGNATURE: \_\_\_\_\_

COMPANY: \_\_\_\_\_

NAME: \_\_\_\_\_  
(Typed or Printed)

ADDRESS: \_\_\_\_\_

TITLE: \_\_\_\_\_

\_\_\_\_\_

E-MAIL: \_\_\_\_\_

\_\_\_\_\_

PHONE NO.: \_\_\_\_\_

**THIS PAGE WAS INTENTIONALLY LEFT BLANK**

# CONFLICT OF INTEREST DISCLOSURE FORM

For purposes of determining any possible conflict of interest, all respondents, must disclose if any Okaloosa Board of County Commissioner, employee(s), elected officials(s), or if any of its agencies is also an owner, corporate officer, agency, employee, etc., of their business.

Indicate either “yes” (a county employee, elected official, or agency is also associated with your business), or “no”. If yes, give person(s) name(s) and position(s) with your business.

YES \_\_\_\_\_

NO \_\_\_\_\_

**NAME(S)**

**POSITION(S)**

---

---

---

---

FIRM NAME: \_\_\_\_\_

BY (PRINTED): \_\_\_\_\_

BY (SIGNATURE): \_\_\_\_\_

TITLE: \_\_\_\_\_

ADDRESS: \_\_\_\_\_

\_\_\_\_\_

PHONE NO. \_\_\_\_\_

E-MAIL \_\_\_\_\_

DATE \_\_\_\_\_

**THIS PAGE WAS INTENTIONALLY LEFT BLANK**

# **FEDERAL E-VERIFY COMPLIANCE CERTIFICATION**

In accordance with Okaloosa County Policy and Executive Order Number 11-116 from the office of the Governor of the State of Florida, Respondent hereby certifies that the U.S. Department of Homeland Security's E-Verify system will be used to verify the employment eligibility of all new employees hired by the respondent during the contract term, and shall expressly require any subcontractors performing work or providing services pursuant to the contact to likewise utilize the U.S. Department of Homeland Securities E-Verify system to verify the employment eligibility of all new employees hired by the subcontractor during the contract term; and shall provide documentation such verification to the COUNTY upon request.

---

---

As the person authorized to sign this statement, I certify that this company complies/will comply fully with the above requirements.

DATE: \_\_\_\_\_

SIGNATURE: \_\_\_\_\_

COMPANY: \_\_\_\_\_

NAME: \_\_\_\_\_

ADDRESS: \_\_\_\_\_

TITLE: \_\_\_\_\_

\_\_\_\_\_

E-MAIL: \_\_\_\_\_

PHONE NO.: \_\_\_\_\_

**THIS PAGE WAS INTENTIONALLY LEFT BLANK**

## INDEMNIFICATION AND HOLD HARMLESS

Respondent shall indemnify and hold harmless the County, its officers and employees from liabilities, damages, losses, and costs including but not limited to reasonable attorney fees, to the extent caused by the negligence, recklessness, or intentional wrongful conduct of the Respondent and other persons employed or utilized by the Respondent in the performance of this Agreement.

\_\_\_\_\_  
Respondent's Company Name

\_\_\_\_\_  
Authorized Signature – Manual

\_\_\_\_\_  
Physical Address

\_\_\_\_\_  
Authorized Signature – Typed

\_\_\_\_\_  
Mailing Address

\_\_\_\_\_  
Title

\_\_\_\_\_  
Phone Number

\_\_\_\_\_  
FAX Number

\_\_\_\_\_  
Cellular Number

\_\_\_\_\_  
After-Hours Number(s)

\_\_\_\_\_  
Date

\_\_\_\_\_  
Email

**THIS PAGE WAS INTENTIONALLY LEFT BLANK**



**LOBBYING - 31 U.S.C. 1352, 49 CFR Part 19, 49 CFR Part 20**

**APPENDIX A, 49 CFR PART 20--CERTIFICATION REGARDING LOBBYING**

**Certification for Contracts, Grants, Loans, and Cooperative Agreements**

*(To be submitted with each bid or offer exceeding \$100,000)*

The undersigned [Contractor] certifies, to the best of his or her knowledge and belief, that:

1. No Federal appropriated funds have been paid or will be paid, by or on behalf of the undersigned, to any person for influencing or attempting to influence an officer or employee of an agency, a Member of Congress, an officer or employee of Congress, or an employee of a Member of Congress in connection with the awarding of any Federal contract, the making of any Federal grant, the making of any Federal loan, the entering into of any cooperative agreement, and the extension, continuation, renewal, amendment, or modification of any Federal contract, grant, loan, or cooperative agreement.
2. If any funds other than Federal appropriated funds have been paid or will be paid to any person for making lobbying contacts to an officer or employee of any agency, a Member of Congress, an officer or employee of Congress, or an employee of a Member of Congress in connection with this Federal contract, grant, loan, or cooperative agreement, the undersigned shall complete and submit Standard Form--LLL, "Disclosure Form to Report Lobbying," in accordance with its instructions [as amended by "Government wide Guidance for New Restrictions on Lobbying," 61 Fed. Reg. 1413 (1/19/96). Note: Language in paragraph (2) herein has been modified in accordance with Section 10 of the Lobbying Disclosure Act of 1995 (P.L. 104-65, to be codified at 2 U.S.C. 1601, *et seq.*)]
3. The undersigned shall require that the language of this certification be included in the award documents for all subawards at all tiers (including subcontracts, subgrants, and contracts under grants, loans, and cooperative agreements) and that all subrecipients shall certify and disclose accordingly.

This certification is a material representation of fact upon which reliance was placed when this transaction was made or entered into. Submission of this certification is a prerequisite for making or entering into this transaction imposed by 31, U.S.C. § 1352 (as amended by the Lobbying Disclosure Act of 1995). Any person who fails to file the required certification shall be subject to a civil penalty of not less than \$10,000 and not more than \$100,000 for each such failure.

[Note: Pursuant to 31 U.S.C. § 1352(c)(1)-(2)(A), any person who makes a prohibited expenditure or fails to file or amend a required certification or disclosure form shall be subject to a civil penalty of not less than \$10,000 and not more than \$100,000 for each such expenditure or failure.]

The Contractor, \_\_\_\_\_, certifies or affirms the truthfulness and accuracy of each statement of its certification and disclosure, if any. In addition, the Contractor understands and agrees that the provisions of 31 U.S.C. A 3801, *et seq.*, apply to this certification and disclosure, if any.

\_\_\_\_\_ Signature of Contractor's Authorized Official

\_\_\_\_\_ Name and Title of Contractor's Authorized Official

\_\_\_\_\_ Date

**THIS PAGE WAS INTENTIONALLY LEFT BLANK**

**CONE OF SILENCE**

The Board of County Commissioners have established a solicitation silence policy (**Cone of Silence**) that prohibits oral and written communication regarding all formal solicitations for goods and services (ITB, RFP, ITQ, ITN, and RFQ) or other competitive solicitation between the bidder (or its agents or representatives) or other entity with the potential for a financial interest in the award (or their respective agents or representatives) regarding such competitive solicitation, and any County Commissioner or County employee, selection committee member or other persons authorized to act on behalf of the Board including the County’s Architect, Engineer or their subconsultants, or anyone designated to provide a recommendation to award a particular contract, other than the Purchasing Department Staff..

The period commences from the time of advertisement until contract award.

Any information thought to affect the committee or staff recommendation submitted after bids are due, should be directed to the Purchasing Manager or an appointed representative. It shall be the Purchasing Manager’s decision whether to consider this information in the decision process.

**Any violation of this policy shall be grounds to disqualify the respondent from consideration during the selection process.**

All respondents must agree to comply with this policy by signing the following statement and including it with their submittal.

I \_\_\_\_\_ representing \_\_\_\_\_  
Signature Company Name

On this \_\_\_\_\_ day of \_\_\_\_\_ 2018 hereby agree to abide by the County’s “**Cone of Silence Clause**” and understand violation of this policy shall result in disqualification of my proposal/submittal.

**THIS PAGE WAS INTENTIONALLY LEFT BLANK**

## **COMPANY DATA**

Respondent's Company Name:

---

Physical Address & Phone #:

---

---

---

---

---

Contact Person (Typed-Printed):

---

Phone #:

---

Cell #:

---

Federal ID or SS #:

---

DUNNS/SAM #:

---

Respondent's License #:

---

Fax #:

---

Emergency #'s After Hours,  
Weekends & Holidays:

---

System for Award Management (Oct 2016)

(a) Definitions. As used in this provision.

“Electronic Funds Transfer (EFT) indicator” means a four-character suffix to the unique entity identifier. The suffix is assigned at the discretion of the commercial, nonprofit, or Government entity to establish additional System for Award Management records for identifying alternative EFT accounts (see [subpart 32.11](#)) for the same entity.

“Registered in the System for Award Management (SAM) database” means that:

(1) The Offeror has entered all mandatory information, including the unique entity identifier and the EFT indicator, if applicable, the Commercial and Government Entity (CAGE) code, as well as data required by the Federal Funding Accountability and Transparency Act of 2006 (see [subpart 4.14](#)) into the SAM database;

(2) The offeror has completed the Core, Assertions, and Representations and Certifications, and Points of Contact sections of the registration in the SAM database;

(3) The Government has validated all mandatory data fields, to include validation of the Taxpayer Identification Number (TIN) with the Internal Revenue Service (IRS). The offeror will be required to provide consent for TIN validation to the Government as a part of the SAM registration process; and

(4) The Government has marked the record “Active”.

“Unique entity identifier” means a number or other identifier used to identify a specific commercial, nonprofit, or Government entity. See [www.sam.gov](http://www.sam.gov) for the designated entity for establishing unique entity identifiers.

(b)(1) By submission of an offer, the offeror acknowledges the requirement that a prospective awardee shall be registered in the SAM database prior to award, during performance, and through final payment of any contract, basic agreement, basic ordering agreement, or blanket purchasing agreement resulting from this solicitation.

(2) The Offeror shall enter, in the block with its name and address on the cover page of its offer, the annotation “Unique Entity Identifier” followed by the unique entity identifier that identifies the Offeror’s name and address exactly as stated in the offer. The Offeror also shall enter its EFT indicator, if applicable. The unique entity identifier will be used by the Contracting Officer to verify that the Offeror is registered in the SAM database.

(c) If the Offeror does not have a unique entity identifier, it should contact the entity designated at [www.sam.gov](http://www.sam.gov) for establishment of the unique entity identifier directly to obtain one. The Offeror should be prepared to provide the following information:

- (1) Company legal business name.
- (2) Tradestyle, doing business, or other name by which your entity is commonly recognized.
- (3) Company Physical Street Address, City, State, and Zip Code.
- (4) Company Mailing Address, City, State and Zip Code (if separate from physical).
- (5) Company telephone number.
- (6) Date the company was started.
- (7) Number of employees at your location.
- (8) Chief executive officer/key manager.
- (9) Line of business (industry).
- (10) Company Headquarters name and address (reporting relationship within your entity).

(d) If the Offeror does not become registered in the SAM database in timely manner, the Contracting Officer may proceed to award to the next otherwise successful registered Offeror.

(e) Processing time, which normally takes 48 hours, should be taken into consideration when registering. Offerors who are not registered should consider applying for registration immediately upon receipt of this solicitation.

(f) Offerors may obtain information on registration at <https://www.acquisition.gov> .

Offerors SAM information:

Entity Name: \_\_\_\_\_

Entity Address: \_\_\_\_\_

Duns Number: \_\_\_\_\_

CAGE Code: \_\_\_\_\_

**ADDENDUM ACKNOWLEDGEMENT**  
**ITB WS 66-18**

Acknowledgment is hereby made of the following addenda (identified by number) received since issuance of solicitation:

<b><u>ADDENDUM NO.</u></b>	<b><u>DATE</u></b>

NOTE: Prior to submitting the response to this solicitation, it is the responsibility of the respondent to confirm if any addenda have been issued. If such addenda have been issued, acknowledge receipt by noting number(s) and date(s) above.

**THIS PAGE WAS INTENTIONALLY LEFT BLANK**



# BID SHEET

**BID #: ITB WS 66-18**

**BASE BID (Items 1-3) – OKALOOSA ISLAND WATER SUPPLY PROJECT - BROOKS BRIDGE WATER MAIN REPLACEMENT**

ITEM	QTY		DESCRIPTION	UNIT PRICE	EXT. PRICE
1	1	LS	Mobilization		
2	1	LS	Erosion Control Measures		
3	1	LS	20-inch Diameter HDPE Directional Drill (Including Drill Pits, Thrust Blocks, and Fittings)		
			<b>TOTAL BASE BID (ITEMS 1-3)</b>	<b>\$</b>	

**BASE BID AMOUNT IS WRITTEN AS:**

\_\_\_\_\_ Dollars and \_\_\_\_\_ Cents,

\$ \_\_\_\_\_, To Be Fully Tested, Shipped and

Delivered to the Project Site within \_\_\_\_\_ Calendar Days from Receipt of Official Purchase Order.

**THIS PAGE WAS INTENTIONALLY LEFT BLANK**

## SECTION C-430

### BID BOND

Any singular reference to Bidder, Surety, Owner or other party shall be considered plural where applicable.

BIDDER (*Name and Address*):

SURETY (*Name, and Address of Principal Place of Business*):

OWNER (*Name and Address*):

Okaloosa County Board of County Commissioners  
5479A Old Bethel Rd.  
Crestview, FL 32536

BID

Bid Due Date:

Project Title - Specification Division:

BOND

Bond Number:

Date:

Penal sum

\$

(Words)

(Figures)

Surety and Bidder, intending to be legally bound hereby, subject to the terms set forth below, do each cause this Bid Bond to be duly executed by an authorized officer, agent, or representative.

**BIDDER**

**SURETY**

(Seal)

(Seal)

Bidder's Name and Corporate Seal

Surety's Name and Corporate Seal

By:

Signature

By:

Signature (Attach Power of Attorney)

Print Name

Print Name

Title

Title

Attest:

Signature

Title

Attest:

Signature

Title

*Note: Addresses are to be used for giving any required notice.*

*Provide execution by any additional parties, such as joint venturers, if necessary.*

1. Bidder and Surety, jointly and severally, bind themselves, their heirs, executors, administrators, successors, and assigns to pay to Owner upon default of Bidder the penal sum set forth on the face of this Bond. Payment of the penal sum is the extent of Bidder's and Surety's liability. Recovery of such penal sum under the terms of this Bond shall be Owner's sole and exclusive remedy upon default of Bidder.

Default of Bidder shall occur upon the failure of Bidder to deliver within the time required by the Bidding Documents (or any extension thereof agreed to in writing by Owner) the executed Agreement required by the Bidding Documents and any performance and payment bonds required by the Bidding Documents.

This obligation shall be null and void if:

Owner accepts Bidder's Bid and Bidder delivers within the time required by the Bidding Documents (or any extension thereof agreed to in writing by Owner) the executed Agreement required by the Bidding Documents and any performance and payment bonds required by the Bidding Documents, or

All Bids are rejected by Owner, or

Owner fails to issue a Notice of Award to Bidder within the time specified in the Bidding Documents (or any extension thereof agreed to in writing by Bidder and, if applicable, consented to by Surety when required by Paragraph 5 hereof).

Payment under this Bond will be due and payable upon default of Bidder and within 30 calendar days after receipt by Bidder and Surety of written notice of default from Owner, which notice will be given with reasonable promptness, identifying this Bond and the Project and including a statement of the amount due.

Surety waives notice of any and all defenses based on or arising out of any time extension to issue Notice of Award agreed to in writing by Owner and Bidder, provided that the total time for issuing Notice of Award including extensions shall not in the aggregate exceed 120 days from the Bid due date without Surety's written consent.

No suit or action shall be commenced under this Bond prior to 30 calendar days after the notice of default required in Paragraph 4 above is received by Bidder and Surety and in no case later than one year after the Bid due date.

Any suit or action under this Bond shall be commenced only in a court of competent jurisdiction located in the state in which the Project is located.

Notices required hereunder shall be in writing and sent to Bidder and Surety at their respective addresses shown on the face of this Bond. Such notices may be sent by personal delivery, commercial courier, or by United States Registered or Certified Mail, return receipt requested, postage pre-paid, and shall be deemed to be effective upon receipt by the party concerned.

Surety shall cause to be attached to this Bond a current and effective Power of Attorney evidencing the authority of the officer, agent, or representative who executed this Bond on behalf of Surety to execute, seal, and deliver such Bond and bind the Surety thereby.

This Bond is intended to conform to all applicable statutory requirements. Any applicable requirement of any applicable statute that has been omitted from this Bond shall be deemed to be included herein as if set forth at length. If any provision of this Bond conflicts with any applicable statute, then the provision of said statute shall govern and the remainder of this Bond that is not in conflict therewith shall continue in full force and effect.

The term "Bid" as used herein includes a Bid, offer, or proposal as applicable.

**SECTION C-451**

**QUALIFICATIONS STATEMENT**

**THE INFORMATION SUPPLIED IN THIS DOCUMENT IS CONFIDENTIAL TO THE EXTENT PERMITTED BY LAWS AND REGULATIONS**

**1. SUBMITTED BY:**

Official Name of Firm: \_\_\_\_\_

Address: \_\_\_\_\_

\_\_\_\_\_

\_\_\_\_\_

**2. SUBMITTED TO:**

\_\_\_\_\_

**3. SUBMITTED FOR:**

\_\_\_\_\_

Owner: \_\_\_\_\_

Project Name: \_\_\_\_\_

\_\_\_\_\_

\_\_\_\_\_

\_\_\_\_\_

**TYPE OF WORK:**

\_\_\_\_\_

\_\_\_\_\_

\_\_\_\_\_

**4. CONTRACTOR'S CONTACT INFORMATION**

Contact Person: \_\_\_\_\_

Title: \_\_\_\_\_

Phone: \_\_\_\_\_

Email: \_\_\_\_\_

**5. AFFILIATED COMPANIES:**

Name: \_\_\_\_\_

Address: \_\_\_\_\_

\_\_\_\_\_

\_\_\_\_\_

**6. TYPE OF ORGANIZATION:**

Top of Form

SOLE PROPRIETORSHIP

Bottom of Form

Name of Owner: \_\_\_\_\_

Doing Business As: \_\_\_\_\_

Date of Organization: \_\_\_\_\_

PARTNERSHIP

Date of Organization: \_\_\_\_\_

Type of Partnership: \_\_\_\_\_

Name of General Partner(s): \_\_\_\_\_

\_\_\_\_\_

\_\_\_\_\_

CORPORATION

State of Organization: \_\_\_\_\_

Date of Organization: \_\_\_\_\_

Executive Officers:

- President: \_\_\_\_\_

- Vice President(s): \_\_\_\_\_

\_\_\_\_\_

- Treasurer:

---

---

- Secretary:

---

LIMITED LIABILITY COMPANY

State of Organization:

---

Date of Organization:

---

Members:

---

---

---

JOINT VENTURE

State of Organization:

---

Date of Organization:

---

Form of Organization:

---

Joint Venture Managing Partner

- Name:

---

- Address:

---

---

Joint Venture Managing Partner

- Name:

---

- Address:

---

---

Joint Venture Managing Partner

- Name:

---

- Address:

---

---

**7. LICENSING**

Jurisdiction: \_\_\_\_\_

Type of License: \_\_\_\_\_

License Number: \_\_\_\_\_

Jurisdiction: \_\_\_\_\_

Type of License: \_\_\_\_\_

License Number: \_\_\_\_\_

**8. CERTIFICATIONS**

CERTIFIED BY:

Disadvantage Business Enterprise: \_\_\_\_\_

Minority Business Enterprise: \_\_\_\_\_

Woman Owned Enterprise: \_\_\_\_\_

Small Business Enterprise: \_\_\_\_\_

Other ( \_\_\_\_\_ ): \_\_\_\_\_

**9. BONDING INFORMATION**

Bonding Company: \_\_\_\_\_

Address: \_\_\_\_\_

Bonding Agent: \_\_\_\_\_

Address: \_\_\_\_\_

Contact Name: \_\_\_\_\_

Phone: \_\_\_\_\_

Aggregate Bonding Capacity: \_\_\_\_\_

Available Bonding Capacity as of date of this submittal: \_\_\_\_\_

**10. FINANCIAL INFORMATION**



Financial Institution: \_\_\_\_\_  
Address: \_\_\_\_\_  
\_\_\_\_\_  
Account Manager: \_\_\_\_\_  
Phone: \_\_\_\_\_

INCLUDE AS AN ATTACHMENT AN AUDITED BALANCE SHEET FOR EACH OF THE  
LAST 3 YEARS

**11. CONSTRUCTION EXPERIENCE:**

Current Experience:

List on **Schedule A** all uncompleted projects currently under contract (If Joint Venture list each participant's projects separately).

Previous Experience:

List on **Schedule B** all projects completed within the last 5 Years (If Joint Venture list each participant's projects separately).

Has firm listed in Section 1 ever failed to complete a construction contract awarded to it?

YES  NO

If YES, attach as an Attachment details including Project Owner's contact information.

Has any Corporate Officer, Partner, Joint Venture participant or Proprietor ever failed to complete a construction contract awarded to them in their name or when acting as a principal of another entity?

YES  NO

If YES, attach as an Attachment details including Project Owner's contact information.

Are there any judgments, claims, disputes or litigation pending or outstanding involving the firm listed in Section 1 or any of its officers (or any of its partners if a partnership or any of the individual entities if a joint venture)?

YES  NO

If YES, attach as an Attachment details including Project Owner's contact information.

**12. SAFETY PROGRAM:**

Name of Contractor's Safety Officer: \_\_\_\_\_

Include the following as attachments:

Provide as an Attachment Contractor's (and Contractor's proposed Subcontractors and Suppliers furnishing or performing Work having a value in excess of 10 percent of the total amount of the Bid) OSHA No. 500- Log & Summary of Occupational Injuries & Illnesses for the past 5 years.

Provide as an Attachment Contractor's (and Contractor's proposed Subcontractors and Suppliers furnishing or performing Work having a value in excess of 10 percent of the total amount of the Bid) list of all OSHA Citations & Notifications of Penalty (monetary or other) received within the last 5 years (indicate disposition as applicable) - IF NONE SO STATE.

Provide as an Attachment Contractor's (and Contractor's proposed Subcontractors and Suppliers furnishing or performing Work having a value in excess of 10 percent of the total amount of the Bid) list of all safety citations or violations under any state all received within the last 5 years (indicate disposition as applicable) - IF NONE SO STATE.

Provide the following for the firm listed in Section V (and for each proposed Subcontractor furnishing or performing Work having a value in excess of 10 percent of the total amount of the Bid) the following (attach additional sheets as necessary):

Workers' compensation Experience Modification Rate (EMR) for the last 5 years:

YEAR	_____	EMR	_____
YEAR	_____	EMR	_____
YEAR	_____	EMR	_____
YEAR	_____	EMR	_____
YEAR	_____	EMR	_____

Total Recordable Frequency Rate (TRFR) for the last 5 years:

YEAR	_____	TRFR	_____
YEAR	_____	TRFR	_____
YEAR	_____	TRFR	_____
YEAR	_____	TRFR	_____
YEAR	_____	TRFR	_____

### 13. EQUIPMENT:

MAJOR EQUIPMENT:

List on **Schedule C** all pieces of major equipment available for use on Owner's Project.

I HEREBY CERTIFY THAT THE INFORMATION SUBMITTED HEREWITH, INCLUDING ANY ATTACHMENTS, IS TRUE TO THE BEST OF MY KNOWLEDGE AND BELIEF.

NAME OF ORGANIZATION: \_\_\_\_\_

BY: \_\_\_\_\_

TITLE: \_\_\_\_\_

DATED: \_\_\_\_\_

NOTARY ATTEST:

SUBSCRIBED AND SWORN TO BEFORE ME

THIS \_\_\_\_\_ DAY OF \_\_\_\_\_, 20\_\_

NOTARY PUBLIC - STATE OF \_\_\_\_\_

MY COMMISSION EXPIRES: \_\_\_\_\_

REQUIRED ATTACHMENTS

1. Schedule A (Current Experience).
2. Schedule B (Previous Experience).
3. Schedule C (Major Equipment).
4. Audited balance sheet for each of the last 3 years for firm named in Section 1.
5. Evidence of authority for individuals listed in Section 7 to bind organization to an agreement.
6. Resumes of officers and key individuals (including Safety Officer) of firm named in Section 1.
7. Required safety program submittals listed in Section 13.
8. Additional items as pertinent.

## SCHEDULE A

### CURRENT EXPERIENCE

Project Name	Owner's Contact Person Name: Address: Telephone:	Design Engineer Name: Company: Telephone:	Contract Date	Type of Work	Status	Cost of Work
	Name: Address: Telephone:	Name: Company: Telephone:				
	Name: Address: Telephone:	Name: Company: Telephone:				
	Name: Address: Telephone:	Name: Company: Telephone:				
	Name: Address: Telephone:	Name: Company: Telephone:				
	Name: Address: Telephone:	Name: Company: Telephone:				
	Name: Address: Telephone:	Name: Company: Telephone:				
	Name: Address: Telephone:	Name: Company: Telephone:				

## SCHEDULE B

### PREVIOUS EXPERIENCE (Include ALL Projects Completed within last 5 years)

Project Name	Owner's Contact Person Name: Address: Telephone:	Design Engineer Name: Company: Telephone:	Contract Date	Type of Work	Status	Cost of Work
	Name: Address: Telephone:	Name: Company: Telephone:				
	Name: Address: Telephone:	Name: Company: Telephone:				
	Name: Address: Telephone:	Name: Company: Telephone:				
	Name: Address: Telephone:	Name: Company: Telephone:				
	Name: Address: Telephone:	Name: Company: Telephone:				
	Name: Address: Telephone:	Name: Company: Telephone:				
	Name: Address: Telephone:	Name: Company: Telephone:				
	Name: Address: Telephone:	Name: Company: Telephone:				

## SCHEDULE B

### PREVIOUS EXPERIENCE (Include ALL Projects Completed within last 5 years)

Project Name	Owner's Contact Person Name: Address: Telephone:	Design Engineer Name: Company: Telephone:	Contract Date	Type of Work	Status	Cost of Work
	Name: Address: Telephone:	Name: Company: Telephone:				
	Name: Address: Telephone:	Name: Company: Telephone:				
	Name: Address: Telephone:	Name: Company: Telephone:				
	Name: Address: Telephone:	Name: Company: Telephone:				
	Name: Address: Telephone:	Name: Company: Telephone:				
	Name: Address: Telephone:	Name: Company: Telephone:				
	Name: Address: Telephone:	Name: Company: Telephone:				

SCHEDULE C - LIST OF MAJOR EQUIPMENT AVAILABLE

ITEM	PURCHASE DATE	CONDITION	ACQUIRED VALUE

## DRAFT CONTRACT

**Please note: this contract is a draft for bidder to view and understand the County's standard terms and conditions, it is subject to revisions. By submitting a bid/proposal bidder/respondent understands and acknowledges that the draft contract is not an offer. Bidders/respondents are not to sign this draft contract.**

### SECTION C-520

#### AGREEMENT BETWEEN OWNER AND CONTRACTOR FOR CONSTRUCTION CONTRACT (STIPULATED PRICE)

THIS AGREEMENT is by and between Okaloosa County Board of County Commissioners ("Owner") and \_\_\_\_\_ ("Contractor").

Owner and Contractor hereby agree as follows:

#### ARTICLE 1 – WORK

1.01 *Contractor shall complete all Work as specified or indicated in the Contract Documents. The Work is generally described as follows:*

#### ARTICLE 2 – THE PROJECT

2.01 *The Project, of which the Work under the Contract Documents is a part, is generally described as follows: Project Title – Specification Division.*

#### ARTICLE 3 – ENGINEER

3.01 *The part of the Project that pertains to the Work has been designed by Consultant.*

3.02 *The Owner has retained ("Engineer") to act as Owner's representative, assume all duties and responsibilities, and have the rights and authority assigned to Engineer in the Contract Documents in connection with the completion of the Work in accordance with the Contract Documents.*

#### ARTICLE 4 – CONTRACT TIMES

4.01 *Time of the Essence*

All time limits for Milestones, if any, Substantial Completion, and completion and readiness for final payment as stated in the Contract Documents are of the essence of the Contract.

4.02 *Contract Times: Days*

The Work will be substantially completed within 180 days after the date when the Contract Times commence to run as provided in Paragraph 4.01 of the General Conditions, and completed and



ready for final payment in accordance with Paragraph 15.06 of the General Conditions within 45 days after the date when the Contract Times commence to run.

#### 4.03 *Liquidated Damages*

- A. Contractor and Owner recognize that time is of the essence as stated in Paragraph 4.01 above and that Owner will suffer financial and other losses if the Work is not completed and Milestones not achieved within the times specified in Paragraph 4.02 above, plus any extensions thereof allowed in accordance with the Contract. The parties also recognize the delays, expense, and difficulties involved in proving in a legal or arbitration proceeding the actual loss suffered by Owner if the Work is not completed on time. Accordingly, instead of requiring any such proof, Owner and Contractor agree that as liquidated damages for delay (but not as a penalty):
1. Substantial Completion: Contractor shall pay Owner \$500 for each day that expires after the time (as duly adjusted pursuant to the Contract) specified in Paragraph 4.02.A above for Substantial Completion until the Work is substantially complete.

### **ARTICLE 5 – CONTRACT PRICE**

5.01 *Owner shall pay Contractor for completion of the Work in accordance with the Contract Documents the amounts that follow, subject to adjustment under the Contract:*

Total of Lump Sum Price         \$   .

### **ARTICLE 6 – PAYMENT PROCEDURES**

#### 6.01 *Submittal and Processing of Payments*

- A. Contractor shall submit Applications for Payment in accordance with Article 15 of the General Conditions. Applications for Payment will be processed by Engineer as provided in the General Conditions.

#### 6.02 *Progress Payments; Retainage*

- A. Owner shall make progress payments on account of the Contract Price on the basis of Contractor's Applications for Payment during performance of the Work as provided in Paragraph 6.02.A.1 below, provided that such Applications for Payment have been submitted in a timely manner and otherwise meet the requirements of the Contract. All such payments will be measured by the Schedule of Values established as provided in the General Conditions (and in the case of Unit Price Work based on the number of units completed) or, in the event there is no Schedule of Values, as provided elsewhere in the Contract.
1. Prior to Substantial Completion, progress payments will be made in an amount equal to the percentage indicated below but, in each case, less the aggregate of payments previously made and less such amounts as Owner may withhold, including but not limited to liquidated damages, in accordance with the Contract

90 percent of Work completed (with the balance being retainage). If the Work has been 50 percent completed as determined by Engineer, and if the character and progress of the Work have been satisfactory to Owner and Engineer, then as long as the character and progress of the Work remain satisfactory to Owner and Engineer, there will be no additional retainage; and

90 percent of cost of materials and equipment not incorporated in the Work (with the balance being retainage).

- B. Upon Substantial Completion, Owner shall pay an amount sufficient to increase total payments to Contractor to 100 percent of the Work completed, less such amounts set off by Owner pursuant to

Paragraph 15.01.E of the General Conditions, and less 200 percent of Engineer's estimate of the value of Work to be completed or corrected as shown on the punch list of items to be completed or corrected prior to final payment.

6.03 *Final Payment*

Upon final completion and acceptance of the Work in accordance with Paragraph 15.06 of the General Conditions, Owner shall pay the remainder of the Contract Price as recommended by Engineer as provided in said Paragraph 15.06.

**ARTICLE 7 – INTEREST**

7.01 *All amounts not paid when due shall bear interest at the rate of 10 percent per annum.*

**ARTICLE 8 – CONTRACTOR'S REPRESENTATIONS**

8.01 *In order to induce Owner to enter into this Contract, Contractor makes the following representations:*

- A. Contractor has examined and carefully studied the Contract Documents, and any data and reference items identified in the Contract Documents.
- B. Contractor has visited the Site, conducted a thorough, alert visual examination of the Site and adjacent areas, and become familiar with and is satisfied as to the general, local, and Site conditions that may affect cost, progress, and performance of the Work.
- C. Contractor is familiar with and is satisfied as to all Laws and Regulations that may affect cost, progress, and performance of the Work.
- D. Contractor has considered the information known to Contractor itself; information commonly known to contractors doing business in the locality of the Site; information and observations obtained from visits to the Site; the Contract Documents; and the Site-related drawings identified in the Contract Documents, with respect to the effect of such information, observations, and documents on (1) the cost, progress, and performance of the Work; (2) the means, methods, techniques, sequences, and procedures of construction to be employed by Contractor; and (3) Contractor's safety precautions and programs.
- E. Based on the information and observations referred to in the preceding paragraph, Contractor agrees that no further examinations, investigations, explorations, tests, studies, or data are necessary for the performance of the Work at the Contract Price, within the Contract Times, and in accordance with the other terms and conditions of the Contract.
- F. Contractor is aware of the general nature of work to be performed by Owner and others at the Site that relates to the Work as indicated in the Contract Documents.
- G. Contractor has given Engineer written notice of all conflicts, errors, ambiguities, or discrepancies that Contractor has discovered in the Contract Documents, and the written resolution thereof by Engineer is acceptable to Contractor.
- H. The Contract Documents are generally sufficient to indicate and convey understanding of all terms and conditions for performance and furnishing of the Work.
- I. Contractor's entry into this Contract constitutes an incontrovertible representation by Contractor that without exception all prices in the Agreement are premised upon performing and furnishing the Work required by the Contract Documents.

## ARTICLE 9 – CONTRACT DOCUMENTS

### 9.01 *Contents*

A. The Contract Documents consist of the following:

1. This Agreement (pages 1 to █, inclusive).
2. Performance bond (pages █ to █, inclusive).
3. Payment bond (pages █ to █, inclusive).
4. General Conditions (pages █ to █, inclusive).
5. Supplementary Conditions (pages █ to █, inclusive).
6. Specifications as listed in the table of contents of the Project Manual.
7. Drawings (not attached but incorporated by reference) consisting of █ sheets with each sheet bearing the following general title: Specification Division for the Project Title.
8. Addenda (numbers █ to █, inclusive).
9. Exhibits to this Agreement (enumerated as follows):

Contractor's Bid (pages █ to █, inclusive).

10. The following which may be delivered or issued on or after the Effective Date of the Contract and are not attached hereto:

Notice to Proceed.

Work Change Directives.

Change Orders.

Field Orders.

- B. The documents listed in Paragraph 9.01.A are attached to this Agreement (except as expressly noted otherwise above).
- C. There are no Contract Documents other than those listed above in this Article 9.
- D. The Contract Documents may only be amended, modified, or supplemented as provided in the General Conditions.

## ARTICLE 10 – MISCELLANEOUS

### 10.01 *Terms*

Terms used in this Agreement will have the meanings stated in the General Conditions and the Supplementary Conditions.

### 10.02 *Assignment of Contract*

Unless expressly agreed to elsewhere in the Contract, no assignment by a party hereto of any rights under or interests in the Contract will be binding on another party hereto without the written consent of the party sought to be bound; and, specifically but without limitation, money that may become due and money that is due may not be assigned without such consent (except to the extent that the effect of this restriction may be limited by law), and unless specifically stated to the contrary in any written consent to an assignment, no assignment will release or discharge the assignor from any duty or responsibility under the Contract Documents.

10.03 *Successors and Assigns*

Owner and Contractor each binds itself, its successors, assigns, and legal representatives to the other party hereto, its successors, assigns, and legal representatives in respect to all covenants, agreements, and obligations contained in the Contract Documents.

10.04 *Severability*

Any provision or part of the Contract Documents held to be void or unenforceable under any Law or Regulation shall be deemed stricken, and all remaining provisions shall continue to be valid and binding upon Owner and Contractor, who agree that the Contract Documents shall be reformed to replace such stricken provision or part thereof with a valid and enforceable provision that comes as close as possible to expressing the intention of the stricken provision.

10.05 *Contractor’s Certifications*

- A. Contractor certifies that it has not engaged in corrupt, fraudulent, collusive, or coercive practices in competing for or in executing the Contract. For the purposes of this Paragraph 10.05:
  1. “corrupt practice” means the offering, giving, receiving, or soliciting of any thing of value likely to influence the action of a public official in the bidding process or in the Contract execution;
  2. “fraudulent practice” means an intentional misrepresentation of facts made (a) to influence the bidding process or the execution of the Contract to the detriment of Owner, (b) to establish Bid or Contract prices at artificial non-competitive levels, or (c) to deprive Owner of the benefits of free and open competition;
  3. “collusive practice” means a scheme or arrangement between two or more Bidders, with or without the knowledge of Owner, a purpose of which is to establish Bid prices at artificial, non-competitive levels; and
  4. “coercive practice” means harming or threatening to harm, directly or indirectly, persons or their property to influence their participation in the bidding process or affect the execution of the Contract.

10.06 *Other Provisions*

- A. Owner stipulates that if the General Conditions that are made a part of this Contract are based on EJCDC® C-700, Standard General Conditions for the Construction Contract, published by the Engineers Joint Contract Documents Committee®, and if Owner is the party that has furnished said General Conditions, then Owner has plainly shown all modifications to the standard wording of such published document to the Contractor, through a process such as highlighting or “track changes” (redline/strikeout), or in the Supplementary Conditions.

IN WITNESS WHEREOF, Owner and Contractor have signed this Agreement.

This Agreement will be effective on \_\_\_\_\_ (which is the Effective Date of the Contract).

OWNER:

CONTRACTOR:

Okaloosa County Board of County Commissioners

By: \_\_\_\_\_

Title: \_\_\_\_\_

Attest: \_\_\_\_\_

Title: \_\_\_\_\_

Address for giving notices:

\_\_\_\_\_  
\_\_\_\_\_  
\_\_\_\_\_

By: \_\_\_\_\_

Title: \_\_\_\_\_

*(If Contractor is a corporation, a partnership, or a joint venture, attach evidence of authority to sign.)*

Attest: \_\_\_\_\_

Title: \_\_\_\_\_

Address for giving notices:

\_\_\_\_\_  
\_\_\_\_\_  
\_\_\_\_\_

License No.: \_\_\_\_\_

*(where applicable)*

*(If Owner is a corporation, attach evidence of authority to sign. If Owner is a public body, attach evidence of authority to sign and resolution or other documents authorizing execution of this Agreement.)*

*NOTE TO USER: Use in those states or other jurisdictions where applicable or required.*

**SECTION C-550  
NOTICE TO PROCEED**

---

Owner: Okaloosa County Board of County Commissioners  
Owner's Contract No.:

Contractor: Contractor's Project No.:

Engineer: Engineer's Project No.:

Project: Contract Name:

Effective Date of Contract:

---

**TO CONTRACTOR:**

Owner hereby notifies Contractor that the Contract Times under the above Contract will commence to run on [REDACTED], 20[REDACTED].

On that date, Contractor shall start performing its obligations under the Contract Documents. No Work shall be done at the Site prior to such date. In accordance with the Agreement, the number of days to achieve Substantial Completion is 180, and the number of days to achieve readiness for final payment is 45.

---

Owner:

Authorized Signature

By:

Title:

Date Issued:

Copy: Engineer

**SECTION C-610**  
**PERFORMANCE BOND**

CONTRACTOR *(name and address):*

SURETY *(name and address of principal place of business):*

OWNER *(name and address):*

Okaloosa County Board County of Commissioners  
5479A Old Bethel Rd  
Crestview, FL 32536

**CONSTRUCTION CONTRACT**

Effective Date of the Agreement:

Amount:

Description:

**BOND**

Bond Number:

Date *(not earlier than the Effective Date of the Agreement of the Construction Contract):*

Amount:

Modifications to this Bond Form:  None  See Paragraph 16

Surety and Contractor, intending to be legally bound hereby, subject to the terms set forth below, do each cause this Performance Bond to be duly executed by an authorized officer, agent, or representative.

**CONTRACTOR AS PRINCIPAL**

**SURETY**

\_\_\_\_\_  
Contractor's Name and Corporate Seal *(seal)*

\_\_\_\_\_  
Surety's Name and Corporate Seal *(seal)*

By: \_\_\_\_\_  
Signature

By: \_\_\_\_\_  
Signature *(attach power of attorney)*

\_\_\_\_\_  
Print Name

\_\_\_\_\_  
Print Name

\_\_\_\_\_  
Title

\_\_\_\_\_  
Title

Attest: \_\_\_\_\_  
Signature

Attest: \_\_\_\_\_  
Signature

\_\_\_\_\_  
Title

\_\_\_\_\_  
Title

**Notes: (1) Provide supplemental execution by any additional parties, such as joint venturers. (2) Any singular reference to Contractor, Surety, Owner, or other party shall be considered plural where applicable.**

1. The Contractor and Surety, jointly and severally, bind themselves, their heirs, executors, administrators, successors, and assigns to the Owner for the performance of the Construction Contract, which is incorporated herein by reference.
2. If the Contractor performs the Construction Contract, the Surety and the Contractor shall have no obligation under this Bond, except when applicable to participate in a conference as provided in Paragraph 3.
3. If there is no Owner Default under the Construction Contract, the Surety's obligation under this Bond shall arise after:
  - 3.1 The Owner first provides notice to the Contractor and the Surety that the Owner is considering declaring a Contractor Default. Such notice shall indicate whether the Owner is requesting a conference among the Owner, Contractor, and Surety to discuss the Contractor's performance. If the Owner does not request a conference, the Surety may, within five (5) business days after receipt of the Owner's notice, request such a conference. If the Surety timely requests a conference, the Owner shall attend. Unless the Owner agrees otherwise, any conference requested under this Paragraph 3.1 shall be held within ten (10) business days of the Surety's receipt of the Owner's notice. If the Owner, the Contractor, and the Surety agree, the Contractor shall be allowed a reasonable time to perform the Construction Contract, but such an agreement shall not waive the Owner's right, if any, subsequently to declare a Contractor Default;
  - 3.2 The Owner declares a Contractor Default, terminates the Construction Contract and notifies the Surety; and
  - 3.3 The Owner has agreed to pay the Balance of the Contract Price in accordance with the terms of the Construction Contract to the Surety or to a contractor selected to perform the Construction Contract.
4. Failure on the part of the Owner to comply with the notice requirement in Paragraph 3.1 shall not constitute a failure to comply with a condition precedent to the Surety's obligations, or release the Surety from its obligations, except to the extent the Surety demonstrates actual prejudice.
5. When the Owner has satisfied the conditions of Paragraph 3, the Surety shall promptly and at the Surety's expense take one of the following actions:
  - 5.1 Arrange for the Contractor, with the consent of the Owner, to perform and complete the Construction Contract;
  - 5.2 Undertake to perform and complete the Construction Contract itself, through its agents or independent contractors;
  - 5.3 Obtain bids or negotiated proposals from qualified contractors acceptable to the Owner for a contract for performance and completion of the Construction Contract, arrange for a contract to be prepared for execution by the Owner and a contractor selected with the Owners concurrence, to be secured with performance and payment bonds executed by a qualified surety equivalent to the bonds issued on the Construction Contract, and pay to the Owner the amount of damages as described in Paragraph 7 in excess of the Balance of the Contract Price incurred by the Owner as a result of the Contractor Default; or
  - 5.4 Waive its right to perform and complete, arrange for completion, or obtain a new contractor, and with reasonable promptness under the circumstances:
    - 5.4.1 After investigation, determine the amount for which it may be liable to the Owner and, as soon as practicable after the amount is determined, make payment to the Owner; or
    - 5.4.2 Deny liability in whole or in part and notify the Owner, citing the reasons for denial.
6. If the Surety does not proceed as provided in Paragraph 5 with reasonable promptness, the Surety shall be deemed to be in default on this Bond seven days after receipt of an additional written notice from the Owner to the Surety demanding that the Surety perform its obligations under this Bond, and the Owner shall be entitled to enforce any remedy available to the Owner. If the Surety proceeds as provided in Paragraph 5.4, and the Owner refuses the payment or the Surety has denied liability, in whole or in part, without further notice the Owner shall be entitled to enforce any remedy available to the Owner.
7. If the Surety elects to act under Paragraph 5.1, 5.2, or 5.3, then the responsibilities of the Surety to the Owner shall not be greater than those of the Contractor under the Construction Contract, and the responsibilities of the Owner to the Surety shall not be greater than those of the Owner under the Construction Contract. Subject to the commitment by the Owner to pay the Balance of the Contract Price, the Surety is obligated, without duplication for:
  - 7.1 the responsibilities of the Contractor for correction of defective work and completion of the Construction Contract;
  - 7.2 additional legal, design professional, and delay costs resulting from the Contractor's Default, and resulting from the actions or failure to act of the Surety under Paragraph 5; and
  - 7.3 liquidated damages, or if no liquidated damages are specified in the Construction Contract, actual damages caused by delayed performance or non-performance of the Contractor.
8. If the Surety elects to act under Paragraph 5.1, 5.3, or 5.4, the Surety's liability is limited to the amount of this Bond.
9. The Surety shall not be liable to the Owner or others for obligations of the Contractor that are unrelated to the Construction



Contract, and the Balance of the Contract Price shall not be reduced or set off on account of any such unrelated obligations. No right of action shall accrue on this Bond to any person or entity other than the Owner or its heirs, executors, administrators, successors, and assigns.

10. The Surety hereby waives notice of any change, including changes of time, to the Construction Contract or to related subcontracts, purchase orders, and other obligations.

11. Any proceeding, legal or equitable, under this Bond may be instituted in any court of competent jurisdiction in the location in which the work or part of the work is located and shall be instituted within two years after a declaration of Contractor Default or within two years after the Contractor ceased working or within two years after the Surety refuses or fails to perform its obligations under this Bond, whichever occurs first. If the provisions of this paragraph are void or prohibited by law, the minimum periods of limitations available to sureties as a defense in the jurisdiction of the suit shall be applicable.

12. Notice to the Surety, the Owner, or the Contractor shall be mailed or delivered to the address shown on the page on which their signature appears.

13. When this Bond has been furnished to comply with a statutory or other legal requirement in the location where the construction was to be performed, any provision in this Bond conflicting with said statutory or legal requirement shall be deemed deleted herefrom and provisions conforming to such statutory or other legal requirement shall be deemed incorporated herein. When so furnished, the intent is that this Bond shall be construed as a statutory bond and not as a common law bond.

#### 14. Definitions

14.1 Balance of the Contract Price: The total amount payable by the Owner to the Contractor under the Construction Contract

after all proper adjustments have been made including allowance for the Contractor for any amounts received or to be received by the Owner in settlement of insurance or other claims for damages to which the Contractor is entitled, reduced by all valid and proper payments made to or on behalf of the Contractor under the Construction Contract.

14.2 Construction Contract: The agreement between the Owner and Contractor identified on the cover page, including all Contract Documents and changes made to the agreement and the Contract Documents.

14.3 Contractor Default: Failure of the Contractor, which has not been remedied or waived, to perform or otherwise to comply with a material term of the Construction Contract.

14.4 Owner Default: Failure of the Owner, which has not been remedied or waived, to pay the Contractor as required under the Construction Contract or to perform and complete or comply with the other material terms of the Construction Contract.

14.5 Contract Documents: All the documents that comprise the agreement between the Owner and Contractor.

15. If this Bond is issued for an agreement between a contractor and subcontractor, the term Contractor in this Bond shall be deemed to be Subcontractor and the term Owner shall be deemed to be Contractor.

16. Modifications to this Bond are as follows:

## SECTION C-615

### PAYMENT BOND

CONTRACTOR *(name and address)*:

SURETY *(name and address of principal place of business)*:

OWNER: Okaloosa County Board County of Commissioners  
5479A Old Bethel Rd  
Crestview, FL 32536

#### CONSTRUCTION CONTRACT

Effective Date of the Agreement:

Amount:

Description:

#### BOND

Bond Number:

Date *(not earlier than the Effective Date of the Agreement of the Construction Contract)*:

Amount:

Modifications to this Bond Form:  None  See Paragraph 18

Surety and Contractor, intending to be legally bound hereby, subject to the terms set forth below, do each cause this Payment Bond to be duly executed by an authorized officer, agent, or representative.

#### CONTRACTOR AS PRINCIPAL

#### SURETY

\_\_\_\_\_  
Contractor's Name and Corporate Seal *(seal)*

\_\_\_\_\_  
Surety's Name and Corporate Seal *(seal)*

By: \_\_\_\_\_  
Signature

By: \_\_\_\_\_  
Signature *(attach power of attorney)*

\_\_\_\_\_  
Print Name

\_\_\_\_\_  
Print Name

\_\_\_\_\_  
Title

\_\_\_\_\_  
Title

Attest: \_\_\_\_\_  
Signature

Attest: \_\_\_\_\_  
Signature

\_\_\_\_\_  
Title

\_\_\_\_\_  
Title

**Notes: (1) Provide supplemental execution by any additional parties, such as joint venturers. (2) Any singular reference to Contractor, Surety, Owner, or other party shall be considered plural where applicable.**

1. The Contractor and Surety, jointly and severally, bind themselves, their heirs, executors, administrators, successors, and assigns to the Owner to pay for labor, materials, and equipment furnished for use in the performance of the Construction Contract, which is incorporated herein by reference, subject to the following terms.
2. If the Contractor promptly makes payment of all sums due to Claimants, and defends, indemnifies, and holds harmless the Owner from claims, demands, liens, or suits by any person or entity seeking payment for labor, materials, or equipment furnished for use in the performance of the Construction Contract, then the Surety and the Contractor shall have no obligation under this Bond.
3. If there is no Owner Default under the Construction Contract, the Surety's obligation to the Owner under this Bond shall arise after the Owner has promptly notified the Contractor and the Surety (at the address described in Paragraph 13) of claims, demands, liens, or suits against the Owner or the Owner's property by any person or entity seeking payment for labor, materials, or equipment furnished for use in the performance of the Construction Contract, and tendered defense of such claims, demands, liens, or suits to the Contractor and the Surety.
4. When the Owner has satisfied the conditions in Paragraph 3, the Surety shall promptly and at the Surety's expense defend, indemnify, and hold harmless the Owner against a duly tendered claim, demand, lien, or suit.
5. The Surety's obligations to a Claimant under this Bond shall arise after the following:
  - 5.1 Claimants who do not have a direct contract with the Contractor,
    - 5.1.1 have furnished a written notice of non-payment to the Contractor, stating with substantial accuracy the amount claimed and the name of the party to whom the materials were, or equipment was, furnished or supplied or for whom the labor was done or performed, within ninety (90) days after having last performed labor or last furnished materials or equipment included in the Claim; and
    - 5.1.2 have sent a Claim to the Surety (at the address described in Paragraph 13).
  - 5.2 Claimants who are employed by or have a direct contract with the Contractor have sent a Claim to the Surety (at the address described in Paragraph 13).
6. If a notice of non-payment required by Paragraph 5.1.1 is given by the Owner to the Contractor, that is sufficient to satisfy a Claimant's obligation to furnish a written notice of non-payment under Paragraph 5.1.1.
7. When a Claimant has satisfied the conditions of Paragraph 5.1 or 5.2, whichever is applicable, the Surety shall promptly and at the Surety's expense take the following actions:
  - 7.1 Send an answer to the Claimant, with a copy to the Owner, within sixty (60) days after receipt of the Claim, stating the amounts that are undisputed and the basis for challenging any amounts that are disputed; and
  - 7.2 Pay or arrange for payment of any undisputed amounts.
  - 7.3 The Surety's failure to discharge its obligations under Paragraph 7.1 or 7.2 shall not be deemed to constitute a waiver of defenses the Surety or Contractor may have or acquire as to a Claim, except as to undisputed amounts for which the Surety and Claimant have reached agreement. If, however, the Surety fails to discharge its obligations under Paragraph 7.1 or 7.2, the Surety shall indemnify the Claimant for the reasonable attorney's fees the Claimant incurs thereafter to recover any sums found to be due and owing to the Claimant.
8. The Surety's total obligation shall not exceed the amount of this Bond, plus the amount of reasonable attorney's fees provided under Paragraph 7.3, and the amount of this Bond shall be credited for any payments made in good faith by the Surety.
9. Amounts owed by the Owner to the Contractor under the Construction Contract shall be used for the performance of the Construction Contract and to satisfy claims, if any, under any construction performance bond. By the Contractor furnishing and the Owner accepting this Bond, they agree that all funds earned by the Contractor in the performance of the Construction Contract are dedicated to satisfy obligations of the Contractor and Surety under this Bond, subject to the Owner's priority to use the funds for the completion of the work.
10. The Surety shall not be liable to the Owner, Claimants, or others for obligations of the Contractor that are unrelated to the Construction Contract. The Owner shall not be liable for the payment of any costs or expenses of any Claimant under this Bond, and shall have under this Bond no obligation to make payments to or give notice on behalf of Claimants, or otherwise have any obligations to Claimants under this Bond.

11. The Surety hereby waives notice of any change, including changes of time, to the Construction Contract or to related subcontracts, purchase orders, and other obligations.
  12. No suit or action shall be commenced by a Claimant under this Bond other than in a court of competent jurisdiction in the state in which the project that is the subject of the Construction Contract is located or after the expiration of one year from the date (1) on which the Claimant sent a Claim to the Surety pursuant to Paragraph 5.1.2 or 5.2, or (2) on which the last labor or service was performed by anyone or the last materials or equipment were furnished by anyone under the Construction Contract, whichever of (1) or (2) first occurs. If the provisions of this paragraph are void or prohibited by law, the minimum period of limitation available to sureties as a defense in the jurisdiction of the suit shall be applicable.
  13. Notice and Claims to the Surety, the Owner, or the Contractor shall be mailed or delivered to the address shown on the page on which their signature appears. Actual receipt of notice or Claims, however accomplished, shall be sufficient compliance as of the date received.
  14. When this Bond has been furnished to comply with a statutory or other legal requirement in the location where the construction was to be performed, any provision in this Bond conflicting with said statutory or legal requirement shall be deemed deleted herefrom and provisions conforming to such statutory or other legal requirement shall be deemed incorporated herein. When so furnished, the intent is that this Bond shall be construed as a statutory bond and not as a common law bond.
  15. Upon requests by any person or entity appearing to be a potential beneficiary of this Bond, the Contractor and Owner shall promptly furnish a copy of this Bond or shall permit a copy to be made.
  16. **Definitions**
    - 16.1 **Claim:** A written statement by the Claimant including at a minimum:
      1. The name of the Claimant;
      2. The name of the person for whom the labor was done, or materials or equipment furnished;
      3. A copy of the agreement or purchase order pursuant to which labor, materials, or equipment was furnished for use in the performance of the Construction Contract;
      4. A brief description of the labor, materials, or equipment furnished;
      5. The date on which the Claimant last performed labor or last furnished materials or equipmentfor use in the performance of the Construction Contract;
    6. The total amount earned by the Claimant for labor, materials, or equipment furnished as of the date of the Claim;
    7. The total amount of previous payments received by the Claimant; and
    8. The total amount due and unpaid to the Claimant for labor, materials, or equipment furnished as of the date of the Claim.
  - 16.2 **Claimant:** An individual or entity having a direct contract with the Contractor or with a subcontractor of the Contractor to furnish labor, materials, or equipment for use in the performance of the Construction Contract. The term Claimant also includes any individual or entity that has rightfully asserted a claim under an applicable mechanic's lien or similar statute against the real property upon which the Project is located. The intent of this Bond shall be to include without limitation in the terms of "labor, materials, or equipment" that part of the water, gas, power, light, heat, oil, gasoline, telephone service, or rental equipment used in the Construction Contract, architectural and engineering services required for performance of the work of the Contractor and the Contractor's subcontractors, and all other items for which a mechanic's lien may be asserted in the jurisdiction where the labor, materials, or equipment were furnished.
  - 16.3 **Construction Contract:** The agreement between the Owner and Contractor identified on the cover page, including all Contract Documents and all changes made to the agreement and the Contract Documents.
  - 16.4 **Owner Default:** Failure of the Owner, which has not been remedied or waived, to pay the Contractor as required under the Construction Contract or to perform and complete or comply with the other material terms of the Construction Contract.
  - 16.5 **Contract Documents:** All the documents that comprise the agreement between the Owner and Contractor.
17. If this Bond is issued for an agreement between a contractor and subcontractor, the term Contractor in this Bond shall be deemed to be Subcontractor and the term Owner shall be deemed to be Contractor.
18. Modifications to this Bond are as follows:

**SECTION C-625  
CERTIFICATE OF SUBSTANTIAL COMPLETION**

Owner: Okaloosa County Board of County Commissioners	Owner's Contract No.:
Contractor:	Contractor's Project No.:
Engineer:	Engineer's Project No.:
Project:	Contract Name:

**This [preliminary] [final] Certificate of Substantial Completion applies to:**

- All Work  The following specified portions of the Work:

**Date of Substantial Completion**

The Work to which this Certificate applies has been inspected by authorized representatives of Owner, Contractor, and Engineer, and found to be substantially complete. The Date of Substantial Completion of the Work or portion thereof designated above is hereby established, subject to the provisions of the Contract pertaining to Substantial Completion. The date of Substantial Completion in the final Certificate of Substantial Completion marks the commencement of the contractual correction period and applicable warranties required by the Contract.

A punch list of items to be completed or corrected is attached to this Certificate. This list may not be all-inclusive, and the failure to include any items on such list does not alter the responsibility of the Contractor to complete all Work in accordance with the Contract.

The responsibilities between Owner and Contractor for security, operation, safety, maintenance, heat, utilities, insurance, and warranties upon Owner's use or occupancy of the Work shall be as provided in the Contract, except as amended as follows: *[Note: Amendments of contractual responsibilities recorded in this Certificate should be the product of mutual agreement of Owner and Contractor; see Paragraph 15.03.D of the General Conditions.]*

Amendments to Owner's responsibilities:  None  
 As follows

Amendments to Contractor's responsibilities:  None  
 As follows:

The following documents are attached to and made a part of this Certificate: *[punch list; others]*

This Certificate does not constitute an acceptance of Work not in accordance with the Contract Documents, nor is it a release of Contractor's obligation to complete the Work in accordance with the Contract.

<b>EXECUTED BY ENGINEER:</b>	<b>RECEIVED:</b>	<b>RECEIVED:</b>
By: _____ (Authorized signature)	By: _____ Owner (Authorized Signature)	By: _____ Contractor (Authorized Signature)
Title: _____	Title: _____	Title: _____
Date: _____	Date: _____	Date: _____



**SECTION C-700  
STANDARD GENERAL CONDITIONS OF THE  
CONSTRUCTION CONTRACT**

**TABLE OF CONTENTS**

	<b>Page</b>
<a href="#"><u>Article 1 – Definitions and Terminology</u></a> .....	1
<a href="#"><u>1.01 Defined Terms</u></a> .....	1
<a href="#"><u>1.02 Terminology</u></a> .....	5
<a href="#"><u>Article 2 – Preliminary Matters</u></a> .....	6
<a href="#"><u>2.01 Delivery of Bonds and Evidence of Insurance</u></a> .....	6
<a href="#"><u>2.02 Copies of Documents</u></a> .....	6
<a href="#"><u>2.03 Before Starting Construction</u></a> .....	6
<a href="#"><u>2.04 Preconstruction Conference; Designation of Authorized Representatives</u></a> .....	7
<a href="#"><u>2.05 Initial Acceptance of Schedules</u></a> .....	7
<a href="#"><u>2.06 Electronic Transmittals</u></a> .....	7
<a href="#"><u>Article 3 – Documents: Intent, Requirements, Reuse</u></a> .....	8
<a href="#"><u>3.01 Intent</u></a> .....	8
<a href="#"><u>3.02 Reference Standards</u></a> .....	8
<a href="#"><u>3.03 Reporting and Resolving Discrepancies</u></a> .....	8
<a href="#"><u>3.04 Requirements of the Contract Documents</u></a> .....	9
<a href="#"><u>3.05 Reuse of Documents</u></a> .....	10
<a href="#"><u>Article 4 – Commencement and Progress of the Work</u></a> .....	10
<a href="#"><u>4.01 Commencement of Contract Times; Notice to Proceed</u></a> .....	10
<a href="#"><u>4.02 Starting the Work</u></a> .....	10
<a href="#"><u>4.03 Reference Points</u></a> .....	10
<a href="#"><u>4.04 Progress Schedule</u></a> .....	11
<a href="#"><u>4.05 Delays in Contractor’s Progress</u></a> .....	11
<a href="#"><u>Article 5 – Availability of Lands; Subsurface and Physical Conditions; Hazardous Environmental Conditions</u></a> .....	12
<a href="#"><u>5.01 Availability of Lands</u></a> .....	12
<a href="#"><u>5.02 Use of Site and Other Areas</u></a> .....	12
<a href="#"><u>5.03 Subsurface and Physical Conditions</u></a> .....	13

5.04	<a href="#">Differing Subsurface or Physical Conditions</a>	14
5.05	<a href="#">Underground Facilities</a>	15
5.06	<a href="#">Hazardous Environmental Conditions at Site</a>	17
<a href="#">Article 6 – Bonds and Insurance</a>		19
6.01	<a href="#">Performance, Payment, and Other Bonds</a>	19
6.02	<a href="#">Insurance—General Provisions</a>	19
6.03	<a href="#">Contractor’s Insurance</a>	20
6.04	<a href="#">Owner’s Liability Insurance</a>	23
6.05	<a href="#">Property Insurance</a>	23
6.06	<a href="#">Waiver of Rights</a>	25
6.07	<a href="#">Receipt and Application of Property Insurance Proceeds</a>	26
<a href="#">Article 7 – Contractor’s Responsibilities</a>		26
7.01	<a href="#">Supervision and Superintendence</a>	26
7.02	<a href="#">Labor; Working Hours</a>	26
7.03	<a href="#">Services, Materials, and Equipment</a>	26
7.04	<a href="#">“Or Equals”</a>	27
7.05	<a href="#">Substitutes</a>	28
7.06	<a href="#">Concerning Subcontractors, Suppliers, and Others</a>	29
7.07	<a href="#">Patent Fees and Royalties</a>	31
7.08	<a href="#">Permits</a>	31
7.09	<a href="#">Taxes</a>	32
7.10	<a href="#">Laws and Regulations</a>	32
7.11	<a href="#">Record Documents</a>	32
7.12	<a href="#">Safety and Protection</a>	32
7.13	<a href="#">Safety Representative</a>	33
7.14	<a href="#">Hazard Communication Programs</a>	34
7.15	<a href="#">Emergencies</a>	34
7.16	<a href="#">Shop Drawings, Samples, and Other Submittals</a>	34
7.17	<a href="#">Contractor’s General Warranty and Guarantee</a>	36
7.18	<a href="#">Indemnification</a>	37
7.19	<a href="#">Delegation of Professional Design Services</a>	37



[Article 8 – Other Work at the Site](#) ..... 38

[8.01 Other Work](#) ..... 38

[8.02 Coordination](#) ..... 39

[8.03 Legal Relationships](#)..... 39

[Article 9 – Owner’s Responsibilities](#)..... 40

[9.01 Communications to Contractor](#)..... 40

[9.02 Replacement of Engineer](#)..... 40

[9.03 Furnish Data](#) ..... 40

[9.04 Pay When Due](#)..... 40

[9.05 Lands and Easements; Reports, Tests, and Drawings](#)..... 40

[9.06 Insurance](#)..... 40

[9.07 Change Orders](#)..... 41

[9.08 Inspections, Tests, and Approvals](#)..... 41

[9.09 Limitations on Owner’s Responsibilities](#) ..... 41

[9.10 Undisclosed Hazardous Environmental Condition](#)..... 41

[9.11 Evidence of Financial Arrangements](#)..... 41

[9.12 Safety Programs](#) ..... 41

[Article 10 – Engineer’s Status During Construction](#)..... 41

[10.01 Owner’s Representative](#)..... 41

[10.02 Visits to Site](#)..... 41

[10.03 Project Representative](#)..... 42

[10.04 Rejecting Defective Work](#)..... 42

[10.05 Shop Drawings, Change Orders and Payments](#)..... 42

[10.06 Determinations for Unit Price Work](#) ..... 42

[10.07 Decisions on Requirements of Contract Documents and Acceptability of Work](#) ..... 42

[10.08 Limitations on Engineer’s Authority and Responsibilities](#)..... 42

[10.09 Compliance with Safety Program](#)..... 43

[Article 11 – Amending the Contract Documents; Changes in the Work](#) ..... 43

[11.01 Amending and Supplementing Contract Documents](#) ..... 43

[11.02 Owner-Authorized Changes in the Work](#) ..... 44

[11.03 Unauthorized Changes in the Work](#) ..... 44

[11.04 Change of Contract Price](#) ..... 44

<u>11.05</u>	<u>Change of Contract Times</u> .....	45
<u>11.06</u>	<u>Change Proposals</u> .....	46
<u>11.07</u>	<u>Execution of Change Orders</u> .....	46
<u>11.08</u>	<u>Notification to Surety</u> .....	47
<u>Article 12 – Claims</u> .....		47
<u>12.01</u>	<u>Claims</u> .....	47
<u>Article 13 – Cost of the Work; Allowances; Unit Price Work</u> .....		48
<u>13.01</u>	<u>Cost of the Work</u> .....	48
<u>13.02</u>	<u>Allowances</u> .....	51
<u>13.03</u>	<u>Unit Price Work</u> .....	51
<u>Article 14 – Tests and Inspections; Correction, Removal or Acceptance of Defective Work</u> .....		52
<u>14.01</u>	<u>Access to Work</u> .....	52
<u>14.02</u>	<u>Tests, Inspections, and Approvals</u> .....	52
<u>14.03</u>	<u>Defective Work</u> .....	53
<u>14.04</u>	<u>Acceptance of Defective Work</u> .....	54
<u>14.05</u>	<u>Uncovering Work</u> .....	54
<u>14.06</u>	<u>Owner May Stop the Work</u> .....	54
<u>14.07</u>	<u>Owner May Correct Defective Work</u> .....	55
<u>Article 15 – Payments to Contractor; Set-Offs; Completion; Correction Period</u> .....		55
<u>15.01</u>	<u>Progress Payments</u> .....	55
<u>15.02</u>	<u>Contractor’s Warranty of Title</u> .....	58
<u>15.03</u>	<u>Substantial Completion</u> .....	58
<u>15.04</u>	<u>Partial Use or Occupancy</u> .....	59
<u>15.05</u>	<u>Final Inspection</u> .....	60
<u>15.06</u>	<u>Final Payment</u> .....	60
<u>15.07</u>	<u>Waiver of Claims</u> .....	61
<u>15.08</u>	<u>Correction Period</u> .....	61
<u>Article 16 – Suspension of Work and Termination</u> .....		62
<u>16.01</u>	<u>Owner May Suspend Work</u> .....	62
<u>16.02</u>	<u>Owner May Terminate for Cause</u> .....	62
<u>16.03</u>	<u>Owner May Terminate For Convenience</u> .....	63
<u>16.04</u>	<u>Contractor May Stop Work or Terminate</u> .....	64

<a href="#">Article 17 – Final Resolution of Disputes</a> .....	64
<a href="#">17.01 Methods and Procedures</a> .....	64
<a href="#">Article 18 – Miscellaneous</a> .....	65
<a href="#">18.01 Giving Notice</a> .....	65
<a href="#">18.02 Computation of Times</a> .....	65
<a href="#">18.03 Cumulative Remedies</a> .....	65
<a href="#">18.04 Limitation of Damages</a> .....	65
<a href="#">18.05 No Waiver</a> .....	65
<a href="#">18.06 Survival of Obligations</a> .....	65
<a href="#">18.07 Controlling Law</a> .....	65
<a href="#">18.08 Headings</a> .....	65

## ARTICLE 1 – DEFINITIONS AND TERMINOLOGY

### 1.01 *Defined Terms*

- A. Wherever used in the Bidding Requirements or Contract Documents, a term printed with initial capital letters, including the term's singular and plural forms, will have the meaning indicated in the definitions below. In addition to terms specifically defined, terms with initial capital letters in the Contract Documents include references to identified articles and paragraphs, and the titles of other documents or forms.
1. *Addenda*—Written or graphic instruments issued prior to the opening of Bids which clarify, correct, or change the Bidding Requirements or the proposed Contract Documents.
  2. *Agreement*—The written instrument, executed by Owner and Contractor, that sets forth the Contract Price and Contract Times, identifies the parties and the Engineer, and designates the specific items that are Contract Documents.
  3. *Application for Payment*—The form acceptable to Engineer which is to be used by Contractor during the course of the Work in requesting progress or final payments and which is to be accompanied by such supporting documentation as is required by the Contract Documents.
  4. *Bid*—The offer of a Bidder submitted on the prescribed form setting forth the prices for the Work to be performed.
  5. *Bidder*—An individual or entity that submits a Bid to Owner.
  6. *Bidding Documents*—The Bidding Requirements, the proposed Contract Documents, and all Addenda.
  7. *Bidding Requirements*—The advertisement or invitation to bid, Instructions to Bidders, Bid Bond or other Bid security, if any, the Bid Form, and the Bid with any attachments.
  8. *Change Order*—A document which is signed by Contractor and Owner and authorizes an addition, deletion, or revision in the Work or an adjustment in the Contract Price or the Contract Times, or other revision to the Contract, issued on or after the Effective Date of the Contract.
  9. *Change Proposal*—A written request by Contractor, duly submitted in compliance with the procedural requirements set forth herein, seeking an adjustment in Contract Price or Contract Times, or both; contesting an initial decision by Engineer concerning the requirements of the Contract Documents or the acceptability of Work under the Contract Documents; challenging a set-off against payments due; or seeking other relief with respect to the terms of the Contract.
  10. *Claim*—(a) A demand or assertion by Owner directly to Contractor, duly submitted in compliance with the procedural requirements set forth herein: seeking an adjustment of Contract Price or Contract Times, or both; contesting an initial decision by Engineer concerning the requirements of the Contract Documents or the acceptability of Work under the Contract Documents; contesting Engineer's decision regarding a Change Proposal; seeking resolution of a contractual issue that Engineer has declined to address; or seeking other relief with respect to the terms of the Contract; or (b) a demand or assertion by Contractor directly to Owner, duly submitted in compliance with the procedural requirements set forth herein, contesting Engineer's decision regarding a Change Proposal;

or seeking resolution of a contractual issue that Engineer has declined to address. A demand for money or services by a third party is not a Claim.

11. *Constituent of Concern*—Asbestos, petroleum, radioactive materials, polychlorinated biphenyls (PCBs), hazardous waste, and any substance, product, waste, or other material of any nature whatsoever that is or becomes listed, regulated, or addressed pursuant to (a) the Comprehensive Environmental Response, Compensation and Liability Act, 42 U.S.C. §§9601 et seq. (“CERCLA”); (b) the Hazardous Materials Transportation Act, 49 U.S.C. §§5101 et seq.; (c) the Resource Conservation and Recovery Act, 42 U.S.C. §§6901 et seq. (“RCRA”); (d) the Toxic Substances Control Act, 15 U.S.C. §§2601 et seq.; (e) the Clean Water Act, 33 U.S.C. §§1251 et seq.; (f) the Clean Air Act, 42 U.S.C. §§7401 et seq.; or (g) any other federal, state, or local statute, law, rule, regulation, ordinance, resolution, code, order, or decree regulating, relating to, or imposing liability or standards of conduct concerning, any hazardous, toxic, or dangerous waste, substance, or material.
12. *Contract*—The entire and integrated written contract between the Owner and Contractor concerning the Work.
13. *Contract Documents*—Those items so designated in the Agreement, and which together comprise the Contract.
14. *Contract Price*—The money that Owner has agreed to pay Contractor for completion of the Work in accordance with the Contract Documents.
15. *Contract Times*—The number of days or the dates by which Contractor shall: (a) achieve Milestones, if any; (b) achieve Substantial Completion; and (c) complete the Work.
16. *Contractor*—The individual or entity with which Owner has contracted for performance of the Work.
17. *Cost of the Work*—See Paragraph 13.01 for definition.
18. *Drawings*—The part of the Contract that graphically shows the scope, extent, and character of the Work to be performed by Contractor.
19. *Effective Date of the Contract*—The date, indicated in the Agreement, on which the Contract becomes effective.
20. *Engineer*—The individual or entity named as such in the Agreement.
21. *Field Order*—A written order issued by Engineer which requires minor changes in the Work but does not change the Contract Price or the Contract Times.
22. *Hazardous Environmental Condition*—The presence at the Site of Constituents of Concern in such quantities or circumstances that may present a danger to persons or property exposed thereto. The presence at the Site of materials that are necessary for the execution of the Work, or that are to be incorporated in the Work, and that are controlled and contained pursuant to industry practices, Laws and Regulations, and the requirements of the Contract, does not establish a Hazardous Environmental Condition.
23. *Laws and Regulations; Laws or Regulations*—Any and all applicable laws, statutes, rules, regulations, ordinances, codes, and orders of any and all governmental bodies, agencies, authorities, and courts having jurisdiction.
24. *Liens*—Charges, security interests, or encumbrances upon Contract-related funds, real property, or personal property.

25. *Milestone*—A principal event in the performance of the Work that the Contract requires Contractor to achieve by an intermediate completion date or by a time prior to Substantial Completion of all the Work.
26. *Notice of Award*—The written notice by Owner to a Bidder of Owner’s acceptance of the Bid.
27. *Notice to Proceed*—A written notice by Owner to Contractor fixing the date on which the Contract Times will commence to run and on which Contractor shall start to perform the Work.
28. *Owner*—The individual or entity with which Contractor has contracted regarding the Work, and which has agreed to pay Contractor for the performance of the Work, pursuant to the terms of the Contract.
29. *Progress Schedule*—A schedule, prepared and maintained by Contractor, describing the sequence and duration of the activities comprising the Contractor’s plan to accomplish the Work within the Contract Times.
30. *Project*—The total undertaking to be accomplished for Owner by engineers, contractors, and others, including planning, study, design, construction, testing, commissioning, and start-up, and of which the Work to be performed under the Contract Documents is a part.
31. *Project Manual*—The written documents prepared for, or made available for, procuring and constructing the Work, including but not limited to the Bidding Documents or other construction procurement documents, geotechnical and existing conditions information, the Agreement, bond forms, General Conditions, Supplementary Conditions, and Specifications. The contents of the Project Manual may be bound in one or more volumes.
32. *Resident Project Representative*—The authorized representative of Engineer assigned to assist Engineer at the Site. As used herein, the term Resident Project Representative or “RPR” includes any assistants or field staff of Resident Project Representative.
33. *Samples*—Physical examples of materials, equipment, or workmanship that are representative of some portion of the Work and that establish the standards by which such portion of the Work will be judged.
34. *Schedule of Submittals*—A schedule, prepared and maintained by Contractor, of required submittals and the time requirements for Engineer’s review of the submittals and the performance of related construction activities.
35. *Schedule of Values*—A schedule, prepared and maintained by Contractor, allocating portions of the Contract Price to various portions of the Work and used as the basis for reviewing Contractor’s Applications for Payment.
36. *Shop Drawings*—All drawings, diagrams, illustrations, schedules, and other data or information that are specifically prepared or assembled by or for Contractor and submitted by Contractor to illustrate some portion of the Work. Shop Drawings, whether approved or not, are not Drawings and are not Contract Documents.
37. *Site*—Lands or areas indicated in the Contract Documents as being furnished by Owner upon which the Work is to be performed, including rights-of-way and easements, and such other lands furnished by Owner which are designated for the use of Contractor.

38. *Specifications*—The part of the Contract that consists of written requirements for materials, equipment, systems, standards, and workmanship as applied to the Work, and certain administrative requirements and procedural matters applicable to the Work.
39. *Subcontractor*—An individual or entity having a direct contract with Contractor or with any other Subcontractor for the performance of a part of the Work.
40. *Substantial Completion*—The time at which the Work (or a specified part thereof) has progressed to the point where, in the opinion of Engineer, the Work (or a specified part thereof) is sufficiently complete, in accordance with the Contract Documents, so that the Work (or a specified part thereof) can be utilized for the purposes for which it is intended. The terms “substantially complete” and “substantially completed” as applied to all or part of the Work refer to Substantial Completion thereof.
41. *Successful Bidder*—The Bidder whose Bid the Owner accepts, and to which the Owner makes an award of contract, subject to stated conditions.
42. *Supplementary Conditions*—The part of the Contract that amends or supplements these General Conditions.
43. *Supplier*—A manufacturer, fabricator, supplier, distributor, materialman, or vendor having a direct contract with Contractor or with any Subcontractor to furnish materials or equipment to be incorporated in the Work by Contractor or a Subcontractor.
44. *Technical Data*—Those items expressly identified as Technical Data in the Supplementary Conditions, with respect to either (a) subsurface conditions at the Site, or physical conditions relating to existing surface or subsurface structures at the Site (except Underground Facilities) or (b) Hazardous Environmental Conditions at the Site. If no such express identifications of Technical Data have been made with respect to conditions at the Site, then the data contained in boring logs, recorded measurements of subsurface water levels, laboratory test results, and other factual, objective information regarding conditions at the Site that are set forth in any geotechnical or environmental report prepared for the Project and made available to Contractor are hereby defined as Technical Data with respect to conditions at the Site under Paragraphs 5.03, 5.04, and 5.06.
45. *Underground Facilities*—All underground pipelines, conduits, ducts, cables, wires, manholes, vaults, tanks, tunnels, or other such facilities or attachments, and any encasements containing such facilities, including but not limited to those that convey electricity, gases, steam, liquid petroleum products, telephone or other communications, fiber optic transmissions, cable television, water, wastewater, storm water, other liquids or chemicals, or traffic or other control systems.
46. *Unit Price Work*—Work to be paid for on the basis of unit prices.
47. *Work*—The entire construction or the various separately identifiable parts thereof required to be provided under the Contract Documents. Work includes and is the result of performing or providing all labor, services, and documentation necessary to produce such construction; furnishing, installing, and incorporating all materials and equipment into such construction; and may include related services such as testing, start-up, and commissioning, all as required by the Contract Documents.

48. *Work Change Directive*—A written directive to Contractor issued on or after the Effective Date of the Contract, signed by Owner and recommended by Engineer, ordering an addition, deletion, or revision in the Work.

1.02 *Terminology*

- A. The words and terms discussed in the following paragraphs are not defined but, when used in the Bidding Requirements or Contract Documents, have the indicated meaning.
- B. Intent of Certain Terms or Adjectives:
1. The Contract Documents include the terms “as allowed,” “as approved,” “as ordered,” “as directed” or terms of like effect or import to authorize an exercise of professional judgment by Engineer. In addition, the adjectives “reasonable,” “suitable,” “acceptable,” “proper,” “satisfactory,” or adjectives of like effect or import are used to describe an action or determination of Engineer as to the Work. It is intended that such exercise of professional judgment, action, or determination will be solely to evaluate, in general, the Work for compliance with the information in the Contract Documents and with the design concept of the Project as a functioning whole as shown or indicated in the Contract Documents (unless there is a specific statement indicating otherwise). The use of any such term or adjective is not intended to and shall not be effective to assign to Engineer any duty or authority to supervise or direct the performance of the Work, or any duty or authority to undertake responsibility contrary to the provisions of Article 10 or any other provision of the Contract Documents.
- C. Day:
1. The word “day” means a calendar day of 24 hours measured from midnight to the next midnight.
- D. Defective:
1. The word “defective,” when modifying the word “Work,” refers to Work that is unsatisfactory, faulty, or deficient in that it:
    - a. does not conform to the Contract Documents; or
    - b. does not meet the requirements of any applicable inspection, reference standard, test, or approval referred to in the Contract Documents; or
    - c. has been damaged prior to Engineer’s recommendation of final payment (unless responsibility for the protection thereof has been assumed by Owner at Substantial Completion in accordance with Paragraph 15.03 or 15.04).
- E. Furnish, Install, Perform, Provide:
1. The word “furnish,” when used in connection with services, materials, or equipment, shall mean to supply and deliver said services, materials, or equipment to the Site (or some other specified location) ready for use or installation and in usable or operable condition.
  2. The word “install,” when used in connection with services, materials, or equipment, shall mean to put into use or place in final position said services, materials, or equipment complete and ready for intended use.



3. The words “perform” or “provide,” when used in connection with services, materials, or equipment, shall mean to furnish and install said services, materials, or equipment complete and ready for intended use.
4. If the Contract Documents establish an obligation of Contractor with respect to specific services, materials, or equipment, but do not expressly use any of the four words “furnish,” “install,” “perform,” or “provide,” then Contractor shall furnish and install said services, materials, or equipment complete and ready for intended use.
- F. Unless stated otherwise in the Contract Documents, words or phrases that have a well-known technical or construction industry or trade meaning are used in the Contract Documents in accordance with such recognized meaning.

## ARTICLE 2 – PRELIMINARY MATTERS

### 2.01 *Delivery of Bonds and Evidence of Insurance*

- A. *Bonds*: When Contractor delivers the executed counterparts of the Agreement to Owner, Contractor shall also deliver to Owner such bonds as Contractor may be required to furnish.
- B. *Evidence of Contractor’s Insurance*: When Contractor delivers the executed counterparts of the Agreement to Owner, Contractor shall also deliver to Owner, with copies to each named insured and additional insured (as identified in the Supplementary Conditions or elsewhere in the Contract), the certificates and other evidence of insurance required to be provided by Contractor in accordance with Article 6.
- C. *Evidence of Owner’s Insurance*: After receipt of the executed counterparts of the Agreement and all required bonds and insurance documentation, Owner shall promptly deliver to Contractor, with copies to each named insured and additional insured (as identified in the Supplementary Conditions or otherwise), the certificates and other evidence of insurance required to be provided by Owner under Article 6.

### 2.02 *Copies of Documents*

- A. Owner shall furnish to Contractor four printed copies of the Contract (including one fully executed counterpart of the Agreement), and one copy in electronic portable document format (PDF). Additional printed copies will be furnished upon request at the cost of reproduction.
- B. Owner shall maintain and safeguard at least one original printed record version of the Contract, including Drawings and Specifications signed and sealed by Engineer and other design professionals. Owner shall make such original printed record version of the Contract available to Contractor for review. Owner may delegate the responsibilities under this provision to Engineer.

### 2.03 *Before Starting Construction*

- A. *Preliminary Schedules*: Within 10 days after the Effective Date of the Contract (or as otherwise specifically required by the Contract Documents), Contractor shall submit to Engineer for timely review:
  1. a preliminary Progress Schedule indicating the times (numbers of days or dates) for starting and completing the various stages of the Work, including any Milestones specified in the Contract;

2. a preliminary Schedule of Submittals; and
3. a preliminary Schedule of Values for all of the Work which includes quantities and prices of items which when added together equal the Contract Price and subdivides the Work into component parts in sufficient detail to serve as the basis for progress payments during performance of the Work. Such prices will include an appropriate amount of overhead and profit applicable to each item of Work.

**2.04** *Preconstruction Conference; Designation of Authorized Representatives*

- A. Before any Work at the Site is started, a conference attended by Owner, Contractor, Engineer, and others as appropriate will be held to establish a working understanding among the parties as to the Work and to discuss the schedules referred to in Paragraph 2.03.A, procedures for handling Shop Drawings, Samples, and other submittals, processing Applications for Payment, electronic or digital transmittals, and maintaining required records.
- B. At this conference Owner and Contractor each shall designate, in writing, a specific individual to act as its authorized representative with respect to the services and responsibilities under the Contract. Such individuals shall have the authority to transmit and receive information, render decisions relative to the Contract, and otherwise act on behalf of each respective party.

**2.05** *Initial Acceptance of Schedules*

- A. At least 10 days before submission of the first Application for Payment a conference, attended by Contractor, Engineer, and others as appropriate, will be held to review for acceptability to Engineer as provided below the schedules submitted in accordance with Paragraph 2.03.A. Contractor shall have an additional 10 days to make corrections and adjustments and to complete and resubmit the schedules. No progress payment shall be made to Contractor until acceptable schedules are submitted to Engineer.
  1. The Progress Schedule will be acceptable to Engineer if it provides an orderly progression of the Work to completion within the Contract Times. Such acceptance will not impose on Engineer responsibility for the Progress Schedule, for sequencing, scheduling, or progress of the Work, nor interfere with or relieve Contractor from Contractor's full responsibility therefor.
  2. Contractor's Schedule of Submittals will be acceptable to Engineer if it provides a workable arrangement for reviewing and processing the required submittals.
  3. Contractor's Schedule of Values will be acceptable to Engineer as to form and substance if it provides a reasonable allocation of the Contract Price to the component parts of the Work.

**2.06** *Electronic Transmittals*

- A. Except as otherwise stated elsewhere in the Contract, the Owner, Engineer, and Contractor may transmit, and shall accept, Project-related correspondence, text, data, documents, drawings, information, and graphics, including but not limited to Shop Drawings and other submittals, in electronic media or digital format, either directly, or through access to a secure Project website.
- B. If the Contract does not establish protocols for electronic or digital transmittals, then Owner, Engineer, and Contractor shall jointly develop such protocols.

- C. When transmitting items in electronic media or digital format, the transmitting party makes no representations as to long term compatibility, usability, or readability of the items resulting from the recipient's use of software application packages, operating systems, or computer hardware differing from those used in the drafting or transmittal of the items, or from those established in applicable transmittal protocols.

### ARTICLE 3 – DOCUMENTS: INTENT, REQUIREMENTS, REUSE

#### 3.01 *Intent*

- A. The Contract Documents are complementary; what is required by one is as binding as if required by all.
- B. It is the intent of the Contract Documents to describe a functionally complete project (or part thereof) to be constructed in accordance with the Contract Documents.
- C. Unless otherwise stated in the Contract Documents, if there is a discrepancy between the electronic or digital versions of the Contract Documents (including any printed copies derived from such electronic or digital versions) and the printed record version, the printed record version shall govern.
- D. The Contract supersedes prior negotiations, representations, and agreements, whether written or oral.
- E. Engineer will issue clarifications and interpretations of the Contract Documents as provided herein.

#### 3.02 *Reference Standards*

- A. Standards Specifications, Codes, Laws and Regulations
  - 1. Reference in the Contract Documents to standard specifications, manuals, reference standards, or codes of any technical society, organization, or association, or to Laws or Regulations, whether such reference be specific or by implication, shall mean the standard specification, manual, reference standard, code, or Laws or Regulations in effect at the time of opening of Bids (or on the Effective Date of the Contract if there were no Bids), except as may be otherwise specifically stated in the Contract Documents.
  - 2. No provision of any such standard specification, manual, reference standard, or code, or any instruction of a Supplier, shall be effective to change the duties or responsibilities of Owner, Contractor, or Engineer, or any of their subcontractors, consultants, agents, or employees, from those set forth in the part of the Contract Documents prepared by or for Engineer. No such provision or instruction shall be effective to assign to Owner, Engineer, or any of their officers, directors, members, partners, employees, agents, consultants, or subcontractors, any duty or authority to supervise or direct the performance of the Work or any duty or authority to undertake responsibility inconsistent with the provisions of the part of the Contract Documents prepared by or for Engineer.

#### 3.03 *Reporting and Resolving Discrepancies*

- A. Reporting Discrepancies:
  - 1. *Contractor's Verification of Figures and Field Measurements:* Before undertaking each part of the Work, Contractor shall carefully study the Contract Documents, and check and verify pertinent figures and dimensions therein, particularly with respect to applicable field

measurements. Contractor shall promptly report in writing to Engineer any conflict, error, ambiguity, or discrepancy that Contractor discovers, or has actual knowledge of, and shall not proceed with any Work affected thereby until the conflict, error, ambiguity, or discrepancy is resolved, by a clarification or interpretation by Engineer, or by an amendment or supplement to the Contract Documents issued pursuant to Paragraph 11.01.

2. *Contractor's Review of Contract Documents:* If, before or during the performance of the Work, Contractor discovers any conflict, error, ambiguity, or discrepancy within the Contract Documents, or between the Contract Documents and (a) any applicable Law or Regulation, (b) actual field conditions, (c) any standard specification, manual, reference standard, or code, or (d) any instruction of any Supplier, then Contractor shall promptly report it to Engineer in writing. Contractor shall not proceed with the Work affected thereby (except in an emergency as required by Paragraph 7.15) until the conflict, error, ambiguity, or discrepancy is resolved, by a clarification or interpretation by Engineer, or by an amendment or supplement to the Contract Documents issued pursuant to Paragraph 11.01.
3. Contractor shall not be liable to Owner or Engineer for failure to report any conflict, error, ambiguity, or discrepancy in the Contract Documents unless Contractor had actual knowledge thereof.

**B. Resolving Discrepancies:**

1. Except as may be otherwise specifically stated in the Contract Documents, the provisions of the part of the Contract Documents prepared by or for Engineer shall take precedence in resolving any conflict, error, ambiguity, or discrepancy between such provisions of the Contract Documents and:
  - a. the provisions of any standard specification, manual, reference standard, or code, or the instruction of any Supplier (whether or not specifically incorporated by reference as a Contract Document); or
  - b. the provisions of any Laws or Regulations applicable to the performance of the Work (unless such an interpretation of the provisions of the Contract Documents would result in violation of such Law or Regulation).

**3.04 Requirements of the Contract Documents**

- A. During the performance of the Work and until final payment, Contractor and Owner shall submit to the Engineer all matters in question concerning the requirements of the Contract Documents (sometimes referred to as requests for information or interpretation—RFIs), or relating to the acceptability of the Work under the Contract Documents, as soon as possible after such matters arise. Engineer will be the initial interpreter of the requirements of the Contract Documents, and judge of the acceptability of the Work thereunder.
- B. Engineer will, with reasonable promptness, render a written clarification, interpretation, or decision on the issue submitted, or initiate an amendment or supplement to the Contract Documents. Engineer's written clarification, interpretation, or decision will be final and binding on Contractor, unless it appeals by submitting a Change Proposal, and on Owner, unless it appeals by filing a Claim.

- C. If a submitted matter in question concerns terms and conditions of the Contract Documents that do not involve (1) the performance or acceptability of the Work under the Contract Documents, (2) the design (as set forth in the Drawings, Specifications, or otherwise), or (3) other engineering or technical matters, then Engineer will promptly give written notice to Owner and Contractor that Engineer is unable to provide a decision or interpretation. If Owner and Contractor are unable to agree on resolution of such a matter in question, either party may pursue resolution as provided in Article 12.

3.05 *Reuse of Documents*

- A. Contractor and its Subcontractors and Suppliers shall not:
1. have or acquire any title to or ownership rights in any of the Drawings, Specifications, or other documents (or copies of any thereof) prepared by or bearing the seal of Engineer or its consultants, including electronic media editions, or reuse any such Drawings, Specifications, other documents, or copies thereof on extensions of the Project or any other project without written consent of Owner and Engineer and specific written verification or adaptation by Engineer; or
  2. have or acquire any title or ownership rights in any other Contract Documents, reuse any such Contract Documents for any purpose without Owner's express written consent, or violate any copyrights pertaining to such Contract Documents.
- B. The prohibitions of this Paragraph 3.05 will survive final payment, or termination of the Contract. Nothing herein shall preclude Contractor from retaining copies of the Contract Documents for record purposes.

**ARTICLE 4 – COMMENCEMENT AND PROGRESS OF THE WORK**

4.01 *Commencement of Contract Times; Notice to Proceed*

- A. The Contract Times will commence to run on the thirtieth day after the Effective Date of the Contract or, if a Notice to Proceed is given, on the day indicated in the Notice to Proceed. A Notice to Proceed may be given at any time within 30 days after the Effective Date of the Contract. ~~In no event will the Contract Times commence to run later than the sixtieth day after the day of Bid opening or the thirtieth day after the Effective Date of the Contract, whichever date is earlier.~~

4.02 *Starting the Work*

- A. Contractor shall start to perform the Work on the date when the Contract Times commence to run. No Work shall be done at the Site prior to such date.

4.03 *Reference Points*

- A. Owner shall provide engineering surveys to establish reference points for construction which in Engineer's judgment are necessary to enable Contractor to proceed with the Work. Contractor shall be responsible for laying out the Work, shall protect and preserve the established reference points and property monuments, and shall make no changes or relocations without the prior written approval of Owner. Contractor shall report to Engineer whenever any reference point or property monument is lost or destroyed or requires relocation because of necessary changes in grades or locations, and shall be responsible for the accurate replacement or relocation of such reference points or property monuments by professionally qualified personnel.

#### 4.04 *Progress Schedule*

- A. Contractor shall adhere to the Progress Schedule established in accordance with Paragraph 2.05 as it may be adjusted from time to time as provided below.
  - 1. Contractor shall submit to Engineer for acceptance (to the extent indicated in Paragraph 2.05) proposed adjustments in the Progress Schedule that will not result in changing the Contract Times.
  - 2. Proposed adjustments in the Progress Schedule that will change the Contract Times shall be submitted in accordance with the requirements of Article 11.
- B. Contractor shall carry on the Work and adhere to the Progress Schedule during all disputes or disagreements with Owner. No Work shall be delayed or postponed pending resolution of any disputes or disagreements, or during any appeal process, except as permitted by Paragraph 16.04, or as Owner and Contractor may otherwise agree in writing.

#### 4.05 *Delays in Contractor's Progress*

- A. If Owner, Engineer, or anyone for whom Owner is responsible, delays, disrupts, or interferes with the performance or progress of the Work, then Contractor shall be entitled to an equitable adjustment in the Contract Times and Contract Price. Contractor's entitlement to an adjustment of the Contract Times is conditioned on such adjustment being essential to Contractor's ability to complete the Work within the Contract Times.
- B. Contractor shall not be entitled to an adjustment in Contract Price or Contract Times for delay, disruption, or interference caused by or within the control of Contractor. Delay, disruption, and interference attributable to and within the control of a Subcontractor or Supplier shall be deemed to be within the control of Contractor.
- C. If Contractor's performance or progress is delayed, disrupted, or interfered with by unanticipated causes not the fault of and beyond the control of Owner, Contractor, and those for which they are responsible, then Contractor shall be entitled to an equitable adjustment in Contract Times. Contractor's entitlement to an adjustment of the Contract Times is conditioned on such adjustment being essential to Contractor's ability to complete the Work within the Contract Times. Such an adjustment shall be Contractor's sole and exclusive remedy for the delays, disruption, and interference described in this paragraph. Causes of delay, disruption, or interference that may give rise to an adjustment in Contract Times under this paragraph include but are not limited to the following:
  - 1. severe and unavoidable natural catastrophes such as fires, floods, epidemics, and earthquakes;
  - 2. abnormal weather conditions;
  - 3. acts or failures to act of utility owners (other than those performing other work at or adjacent to the Site by arrangement with the Owner, as contemplated in Article 8); and
  - 4. acts of war or terrorism.
- D. Delays, disruption, and interference to the performance or progress of the Work resulting from the existence of a differing subsurface or physical condition, an Underground Facility that was not shown or indicated by the Contract Documents, or not shown or indicated with reasonable accuracy, and those resulting from Hazardous Environmental Conditions, are governed by Article 5.

- E. Paragraph 8.03 governs delays, disruption, and interference to the performance or progress of the Work resulting from the performance of certain other work at or adjacent to the Site.
- F. Contractor shall not be entitled to an adjustment in Contract Price or Contract Times for any delay, disruption, or interference if such delay is concurrent with a delay, disruption, or interference caused by or within the control of Contractor.
- G. Contractor must submit any Change Proposal seeking an adjustment in Contract Price or Contract Times under this paragraph within 30 days of the commencement of the delaying, disrupting, or interfering event.

## **ARTICLE 5 – AVAILABILITY OF LANDS; SUBSURFACE AND PHYSICAL CONDITIONS; HAZARDOUS ENVIRONMENTAL CONDITIONS**

### **5.01 *Availability of Lands***

- A. Owner shall furnish the Site. Owner shall notify Contractor of any encumbrances or restrictions not of general application but specifically related to use of the Site with which Contractor must comply in performing the Work.
- B. Upon reasonable written request, Owner shall furnish Contractor with a current statement of record legal title and legal description of the lands upon which permanent improvements are to be made and Owner's interest therein as necessary for giving notice of or filing a mechanic's or construction lien against such lands in accordance with applicable Laws and Regulations.
- C. Contractor shall provide for all additional lands and access thereto that may be required for temporary construction facilities or storage of materials and equipment.

### **5.02 *Use of Site and Other Areas***

- A. Limitation on Use of Site and Other Areas:
  - 1. Contractor shall confine construction equipment, temporary construction facilities, the storage of materials and equipment, and the operations of workers to the Site, adjacent areas that Contractor has arranged to use through construction easements or otherwise, and other adjacent areas permitted by Laws and Regulations, and shall not unreasonably encumber the Site and such other adjacent areas with construction equipment or other materials or equipment. Contractor shall assume full responsibility for (a) damage to the Site; (b) damage to any such other adjacent areas used for Contractor's operations; (c) damage to any other adjacent land or areas; and (d) for injuries and losses sustained by the owners or occupants of any such land or areas; provided that such damage or injuries result from the performance of the Work or from other actions or conduct of the Contractor or those for which Contractor is responsible.
  - 2. If a damage or injury claim is made by the owner or occupant of any such land or area because of the performance of the Work, or because of other actions or conduct of the Contractor or those for which Contractor is responsible, Contractor shall (a) take immediate corrective or remedial action as required by Paragraph 7.12, or otherwise; (b) promptly attempt to settle the claim as to all parties through negotiations with such owner or occupant, or otherwise resolve the claim by arbitration or other dispute resolution proceeding, or at law; and (c) to the fullest extent permitted by Laws and Regulations, indemnify and hold harmless Owner and Engineer, and the officers, directors, members, partners, employees, agents, consultants and subcontractors of each and any of them from

and against any such claim, and against all costs, losses, and damages (including but not limited to all fees and charges of engineers, architects, attorneys, and other professionals and all court or arbitration or other dispute resolution costs) arising out of or relating to any claim or action, legal or equitable, brought by any such owner or occupant against Owner, Engineer, or any other party indemnified hereunder to the extent caused directly or indirectly, in whole or in part by, or based upon, Contractor's performance of the Work, or because of other actions or conduct of the Contractor or those for which Contractor is responsible.

- B. *Removal of Debris During Performance of the Work:* During the progress of the Work the Contractor shall keep the Site and other adjacent areas free from accumulations of waste materials, rubbish, and other debris. Removal and disposal of such waste materials, rubbish, and other debris shall conform to applicable Laws and Regulations.
- C. *Cleaning:* Prior to Substantial Completion of the Work Contractor shall clean the Site and the Work and make it ready for utilization by Owner. At the completion of the Work Contractor shall remove from the Site and adjacent areas all tools, appliances, construction equipment and machinery, and surplus materials and shall restore to original condition all property not designated for alteration by the Contract Documents.
- D. *Loading of Structures:* Contractor shall not load nor permit any part of any structure to be loaded in any manner that will endanger the structure, nor shall Contractor subject any part of the Work or adjacent structures or land to stresses or pressures that will endanger them.

### 5.03 *Subsurface and Physical Conditions*

- A. *Reports and Drawings:* The Supplementary Conditions identify:
  - 1. those reports known to Owner of explorations and tests of subsurface conditions at or adjacent to the Site;
  - 2. those drawings known to Owner of physical conditions relating to existing surface or subsurface structures at the Site (except Underground Facilities); and
  - 3. Technical Data contained in such reports and drawings.
- B. *Reliance by Contractor on Technical Data Authorized:* Contractor may rely upon the accuracy of the Technical Data expressly identified in the Supplementary Conditions with respect to such reports and drawings, but such reports and drawings are not Contract Documents. If no such express identification has been made, then Contractor may rely upon the accuracy of the Technical Data (as defined in Article 1) contained in any geotechnical or environmental report prepared for the Project and made available to Contractor. Except for such reliance on Technical Data, Contractor may not rely upon or make any claim against Owner or Engineer, or any of their officers, directors, members, partners, employees, agents, consultants, or subcontractors, with respect to:
  - 1. the completeness of such reports and drawings for Contractor's purposes, including, but not limited to, any aspects of the means, methods, techniques, sequences, and procedures of construction to be employed by Contractor, and safety precautions and programs incident thereto; or
  - 2. other data, interpretations, opinions, and information contained in such reports or shown or indicated in such drawings; or



3. any Contractor interpretation of or conclusion drawn from any Technical Data or any such other data, interpretations, opinions, or information.

5.04 *Differing Subsurface or Physical Conditions*

- A. *Notice by Contractor:* If Contractor believes that any subsurface or physical condition that is uncovered or revealed at the Site either:
1. is of such a nature as to establish that any Technical Data on which Contractor is entitled to rely as provided in Paragraph 5.03 is materially inaccurate; or
  2. is of such a nature as to require a change in the Drawings or Specifications; or
  3. differs materially from that shown or indicated in the Contract Documents; or
  4. is of an unusual nature, and differs materially from conditions ordinarily encountered and generally recognized as inherent in work of the character provided for in the Contract Documents;

then Contractor shall, promptly after becoming aware thereof and before further disturbing the subsurface or physical conditions or performing any Work in connection therewith (except in an emergency as required by Paragraph 7.15), notify Owner and Engineer in writing about such condition. Contractor shall not further disturb such condition or perform any Work in connection therewith (except with respect to an emergency) until receipt of a written statement permitting Contractor to do so.

- B. *Engineer's Review:* After receipt of written notice as required by the preceding paragraph, Engineer will promptly review the subsurface or physical condition in question; determine the necessity of Owner's obtaining additional exploration or tests with respect to the condition; conclude whether the condition falls within any one or more of the differing site condition categories in Paragraph 5.04.A above; obtain any pertinent cost or schedule information from Contractor; prepare recommendations to Owner regarding the Contractor's resumption of Work in connection with the subsurface or physical condition in question and the need for any change in the Drawings or Specifications; and advise Owner in writing of Engineer's findings, conclusions, and recommendations.
- C. *Owner's Statement to Contractor Regarding Site Condition:* After receipt of Engineer's written findings, conclusions, and recommendations, Owner shall issue a written statement to Contractor (with a copy to Engineer) regarding the subsurface or physical condition in question, addressing the resumption of Work in connection with such condition, indicating whether any change in the Drawings or Specifications will be made, and adopting or rejecting Engineer's written findings, conclusions, and recommendations, in whole or in part.
- D. *Possible Price and Times Adjustments:*
1. Contractor shall be entitled to an equitable adjustment in Contract Price or Contract Times, or both, to the extent that the existence of a differing subsurface or physical condition, or any related delay, disruption, or interference, causes an increase or decrease in Contractor's cost of, or time required for, performance of the Work; subject, however, to the following:
    - a. such condition must fall within any one or more of the categories described in Paragraph 5.04.A;

- b. with respect to Work that is paid for on a unit price basis, any adjustment in Contract Price will be subject to the provisions of Paragraph 13.03; and,
  - c. Contractor's entitlement to an adjustment of the Contract Times is conditioned on such adjustment being essential to Contractor's ability to complete the Work within the Contract Times.
2. Contractor shall not be entitled to any adjustment in the Contract Price or Contract Times with respect to a subsurface or physical condition if:
    - a. Contractor knew of the existence of such condition at the time Contractor made a commitment to Owner with respect to Contract Price and Contract Times by the submission of a Bid or becoming bound under a negotiated contract, or otherwise; or
    - b. the existence of such condition reasonably could have been discovered or revealed as a result of any examination, investigation, exploration, test, or study of the Site and contiguous areas expressly required by the Bidding Requirements or Contract Documents to be conducted by or for Contractor prior to Contractor's making such commitment; or
    - c. Contractor failed to give the written notice as required by Paragraph 5.04.A.
  3. If Owner and Contractor agree regarding Contractor's entitlement to and the amount or extent of any adjustment in the Contract Price or Contract Times, or both, then any such adjustment shall be set forth in a Change Order.
  4. Contractor may submit a Change Proposal regarding its entitlement to or the amount or extent of any adjustment in the Contract Price or Contract Times, or both, no later than 30 days after Owner's issuance of the Owner's written statement to Contractor regarding the subsurface or physical condition in question.

#### 5.05 *Underground Facilities*

- A. *Contractor's Responsibilities:* The information and data shown or indicated in the Contract Documents with respect to existing Underground Facilities at or adjacent to the Site is based on information and data furnished to Owner or Engineer by the owners of such Underground Facilities, including Owner, or by others. Unless it is otherwise expressly provided in the Supplementary Conditions:
  1. Owner and Engineer do not warrant or guarantee the accuracy or completeness of any such information or data provided by others; and
  2. the cost of all of the following will be included in the Contract Price, and Contractor shall have full responsibility for:
    - a. reviewing and checking all information and data regarding existing Underground Facilities at the Site;
    - b. locating all Underground Facilities shown or indicated in the Contract Documents as being at the Site;
    - c. coordination of the Work with the owners (including Owner) of such Underground Facilities, during construction; and
    - d. the safety and protection of all existing Underground Facilities at the Site, and repairing any damage thereto resulting from the Work.

- B. *Notice by Contractor:* If Contractor believes that an Underground Facility that is uncovered or revealed at the Site was not shown or indicated in the Contract Documents, or was not shown or indicated with reasonable accuracy, then Contractor shall, promptly after becoming aware thereof and before further disturbing conditions affected thereby or performing any Work in connection therewith (except in an emergency as required by Paragraph 7.15), identify the owner of such Underground Facility and give written notice to that owner and to Owner and Engineer.
- C. *Engineer's Review:* Engineer will promptly review the Underground Facility and conclude whether such Underground Facility was not shown or indicated in the Contract Documents, or was not shown or indicated with reasonable accuracy; obtain any pertinent cost or schedule information from Contractor; prepare recommendations to Owner regarding the Contractor's resumption of Work in connection with the Underground Facility in question; determine the extent, if any, to which a change is required in the Drawings or Specifications to reflect and document the consequences of the existence or location of the Underground Facility; and advise Owner in writing of Engineer's findings, conclusions, and recommendations. During such time, Contractor shall be responsible for the safety and protection of such Underground Facility.
- D. *Owner's Statement to Contractor Regarding Underground Facility:* After receipt of Engineer's written findings, conclusions, and recommendations, Owner shall issue a written statement to Contractor (with a copy to Engineer) regarding the Underground Facility in question, addressing the resumption of Work in connection with such Underground Facility, indicating whether any change in the Drawings or Specifications will be made, and adopting or rejecting Engineer's written findings, conclusions, and recommendations in whole or in part.
- E. Possible Price and Times Adjustments:
1. Contractor shall be entitled to an equitable adjustment in the Contract Price or Contract Times, or both, to the extent that any existing Underground Facility at the Site that was not shown or indicated in the Contract Documents, or was not shown or indicated with reasonable accuracy, or any related delay, disruption, or interference, causes an increase or decrease in Contractor's cost of, or time required for, performance of the Work; subject, however, to the following:
    - a. Contractor did not know of and could not reasonably have been expected to be aware of or to have anticipated the existence or actual location of the Underground Facility in question;
    - b. With respect to Work that is paid for on a unit price basis, any adjustment in Contract Price will be subject to the provisions of Paragraph 13.03;
    - c. Contractor's entitlement to an adjustment of the Contract Times is conditioned on such adjustment being essential to Contractor's ability to complete the Work within the Contract Times; and
    - d. Contractor gave the notice required in Paragraph 5.05.B.
  2. If Owner and Contractor agree regarding Contractor's entitlement to and the amount or extent of any adjustment in the Contract Price or Contract Times, or both, then any such adjustment shall be set forth in a Change Order.

3. Contractor may submit a Change Proposal regarding its entitlement to or the amount or extent of any adjustment in the Contract Price or Contract Times, or both, no later than 30 days after Owner's issuance of the Owner's written statement to Contractor regarding the Underground Facility in question.

5.06 ~~Hazardous Environmental Conditions at Site~~

~~A. Reports and Drawings: The Supplementary Conditions identify:~~

- ~~1. those reports and drawings known to Owner relating to Hazardous Environmental Conditions that have been identified at or adjacent to the Site; and~~
- ~~2. Technical Data contained in such reports and drawings.~~

~~B. Reliance by Contractor on Technical Data Authorized: Contractor may rely upon the accuracy of the Technical Data expressly identified in the Supplementary Conditions with respect to such reports and drawings, but such reports and drawings are not Contract Documents. If no such express identification has been made, then Contractor may rely on the accuracy of the Technical Data (as defined in Article 1) contained in any geotechnical or environmental report prepared for the Project and made available to Contractor. Except for such reliance on Technical Data, Contractor may not rely upon or make any claim against Owner or Engineer, or any of their officers, directors, members, partners, employees, agents, consultants, or subcontractors with respect to:~~

- ~~1. the completeness of such reports and drawings for Contractor's purposes, including, but not limited to, any aspects of the means, methods, techniques, sequences and procedures of construction to be employed by Contractor and safety precautions and programs incident thereto; or~~
- ~~2. other data, interpretations, opinions and information contained in such reports or shown or indicated in such drawings; or~~
- ~~3. any Contractor interpretation of or conclusion drawn from any Technical Data or any such other data, interpretations, opinions or information.~~

~~C. Contractor shall not be responsible for removing or remediating any Hazardous Environmental Condition encountered, uncovered, or revealed at the Site unless such removal or remediation is expressly identified in the Contract Documents to be within the scope of the Work.~~

~~D. Contractor shall be responsible for controlling, containing, and duly removing all Constituents of Concern brought to the Site by Contractor, Subcontractors, Suppliers, or anyone else for whom Contractor is responsible, and for any associated costs; and for the costs of removing and remediating any Hazardous Environmental Condition created by the presence of any such Constituents of Concern.~~

~~E. If Contractor encounters, uncovers, or reveals a Hazardous Environmental Condition whose removal or remediation is not expressly identified in the Contract Documents as being within the scope of the Work, or if Contractor or anyone for whom Contractor is responsible creates a Hazardous Environmental Condition, then Contractor shall immediately: (1) secure or otherwise isolate such condition; (2) stop all Work in connection with such condition and in any area affected thereby (except in an emergency as required by Paragraph 7.15); and (3) notify Owner and Engineer (and promptly thereafter confirm such notice in writing). Owner shall promptly consult with Engineer concerning the necessity for Owner to retain a qualified expert to evaluate such condition or take corrective action, if any. Promptly after consulting~~

~~with Engineer, Owner shall take such actions as are necessary to permit Owner to timely obtain required permits and provide Contractor the written notice required by Paragraph 5.06.F. If Contractor or anyone for whom Contractor is responsible created the Hazardous Environmental Condition in question, then Owner may remove and remediate the Hazardous Environmental Condition, and impose a set-off against payments to account for the associated costs.~~

- ~~F. Contractor shall not resume Work in connection with such Hazardous Environmental Condition or in any affected area until after Owner has obtained any required permits related thereto, and delivered written notice to Contractor either (1) specifying that such condition and any affected area is or has been rendered safe for the resumption of Work, or (2) specifying any special conditions under which such Work may be resumed safely.~~
- ~~G. If Owner and Contractor cannot agree as to entitlement to or on the amount or extent, if any, of any adjustment in Contract Price or Contract Times, or both, as a result of such Work stoppage or such special conditions under which Work is agreed to be resumed by Contractor, then within 30 days of Owner's written notice regarding the resumption of Work, Contractor may submit a Change Proposal, or Owner may impose a set-off.~~
- ~~H. If after receipt of such written notice Contractor does not agree to resume such Work based on a reasonable belief it is unsafe, or does not agree to resume such Work under such special conditions, then Owner may order the portion of the Work that is in the area affected by such condition to be deleted from the Work, following the contractual change procedures in Article 11. Owner may have such deleted portion of the Work performed by Owner's own forces or others in accordance with Article 8.~~
- ~~I. To the fullest extent permitted by Laws and Regulations, Owner shall indemnify and hold harmless Contractor, Subcontractors, and Engineer, and the officers, directors, members, partners, employees, agents, consultants, and subcontractors of each and any of them from and against all claims, costs, losses, and damages (including but not limited to all fees and charges of engineers, architects, attorneys, and other professionals and all court or arbitration or other dispute resolution costs) arising out of or relating to a Hazardous Environmental Condition, provided that such Hazardous Environmental Condition (1) was not shown or indicated in the Drawings, Specifications, or other Contract Documents, identified as Technical Data entitled to limited reliance pursuant to Paragraph 5.06.B, or identified in the Contract Documents to be included within the scope of the Work, and (2) was not created by Contractor or by anyone for whom Contractor is responsible. Nothing in this Paragraph 5.06.I shall obligate Owner to indemnify any individual or entity from and against the consequences of that individual's or entity's own negligence.~~
- ~~J. To the fullest extent permitted by Laws and Regulations, Contractor shall indemnify and hold harmless Owner and Engineer, and the officers, directors, members, partners, employees, agents, consultants, and subcontractors of each and any of them from and against all claims, costs, losses, and damages (including but not limited to all fees and charges of engineers, architects, attorneys, and other professionals and all court or arbitration or other dispute resolution costs) arising out of or relating to the failure to control, contain, or remove a Constituent of Concern brought to the Site by Contractor or by anyone for whom Contractor is responsible, or to a Hazardous Environmental Condition created by Contractor or by anyone for whom Contractor is responsible. Nothing in this Paragraph 5.06.J shall obligate Contractor to indemnify any individual or entity from and against the consequences of that individual's or entity's own negligence.~~

~~K. The provisions of Paragraphs 5.03, 5.04, and 5.05 do not apply to the presence of Constituents of Concern or to a Hazardous Environmental Condition uncovered or revealed at the Site.~~

## ARTICLE 6 – BONDS AND INSURANCE

### 6.01 *Performance, Payment, and Other Bonds*

- A. Contractor shall furnish a performance bond and a payment bond, each in an amount at least equal to the Contract Price, as security for the faithful performance and payment of all of Contractor's obligations under the Contract. These bonds shall remain in effect until one year after the date when final payment becomes due or until completion of the correction period specified in Paragraph 15.08, whichever is later, except as provided otherwise by Laws or Regulations, the Supplementary Conditions, or other specific provisions of the Contract. Contractor shall also furnish such other bonds as are required by the Supplementary Conditions or other specific provisions of the Contract.
- B. All bonds shall be in the form prescribed by the Contract except as provided otherwise by Laws or Regulations, and shall be executed by such sureties as are named in "Companies Holding Certificates of Authority as Acceptable Sureties on Federal Bonds and as Acceptable Reinsuring Companies" as published in Circular 570 (as amended and supplemented) by the Financial Management Service, Surety Bond Branch, U.S. Department of the Treasury. A bond signed by an agent or attorney-in-fact must be accompanied by a certified copy of that individual's authority to bind the surety. The evidence of authority shall show that it is effective on the date the agent or attorney-in-fact signed the accompanying bond.
- C. Contractor shall obtain the required bonds from surety companies that are duly licensed or authorized in the jurisdiction in which the Project is located to issue bonds in the required amounts.
- D. If the surety on a bond furnished by Contractor is declared bankrupt or becomes insolvent, or its right to do business is terminated in any state or jurisdiction where any part of the Project is located, or the surety ceases to meet the requirements above, then Contractor shall promptly notify Owner and Engineer and shall, within 20 days after the event giving rise to such notification, provide another bond and surety, both of which shall comply with the bond and surety requirements above.
- E. If Contractor has failed to obtain a required bond, Owner may exclude the Contractor from the Site and exercise Owner's termination rights under Article 16.
- F. Upon request, Owner shall provide a copy of the payment bond to any Subcontractor, Supplier, or other person or entity claiming to have furnished labor or materials used in the performance of the Work.

### 6.02 *Insurance—General Provisions*

- A. Owner and Contractor shall obtain and maintain insurance as required in this Article and in the Supplementary Conditions.
- B. All insurance required by the Contract to be purchased and maintained by Owner or Contractor shall be obtained from insurance companies that are duly licensed or authorized, in the state or jurisdiction in which the Project is located, to issue insurance policies for the required limits and coverages. Unless a different standard is indicated in the Supplementary

Conditions, all companies that provide insurance policies required under this Contract shall have an A.M. Best rating of A-VII or better.

- C. Contractor shall deliver to Owner, with copies to each named insured and additional insured (as identified in this Article, in the Supplementary Conditions, or elsewhere in the Contract), certificates of insurance establishing that Contractor has obtained and is maintaining the policies, coverages, and endorsements required by the Contract. Upon request by Owner or any other insured, Contractor shall also furnish other evidence of such required insurance, including but not limited to copies of policies and endorsements, and documentation of applicable self-insured retentions and deductibles. Contractor may block out (redact) any confidential premium or pricing information contained in any policy or endorsement furnished under this provision.
- D. Owner shall deliver to Contractor, with copies to each named insured and additional insured (as identified in this Article, the Supplementary Conditions, or elsewhere in the Contract), certificates of insurance establishing that Owner has obtained and is maintaining the policies, coverages, and endorsements required of Owner by the Contract (if any). Upon request by Contractor or any other insured, Owner shall also provide other evidence of such required insurance (if any), including but not limited to copies of policies and endorsements, and documentation of applicable self-insured retentions and deductibles. Owner may block out (redact) any confidential premium or pricing information contained in any policy or endorsement furnished under this provision.
- E. Failure of Owner or Contractor to demand such certificates or other evidence of the other party's full compliance with these insurance requirements, or failure of Owner or Contractor to identify a deficiency in compliance from the evidence provided, shall not be construed as a waiver of the other party's obligation to obtain and maintain such insurance.
- F. If either party does not purchase or maintain all of the insurance required of such party by the Contract, such party shall notify the other party in writing of such failure to purchase prior to the start of the Work, or of such failure to maintain prior to any change in the required coverage.
- G. If Contractor has failed to obtain and maintain required insurance, Owner may exclude the Contractor from the Site, impose an appropriate set-off against payment, and exercise Owner's termination rights under Article 16.
- H. Without prejudice to any other right or remedy, if a party has failed to obtain required insurance, the other party may elect to obtain equivalent insurance to protect such other party's interests at the expense of the party who was required to provide such coverage, and the Contract Price shall be adjusted accordingly.
- I. Owner does not represent that insurance coverage and limits established in this Contract necessarily will be adequate to protect Contractor or Contractor's interests.
- J. The insurance and insurance limits required herein shall not be deemed as a limitation on Contractor's liability under the indemnities granted to Owner and other individuals and entities in the Contract.

#### 6.03 *Contractor's Insurance*

- A. *Workers' Compensation:* Contractor shall purchase and maintain workers' compensation and employer's liability insurance for:

1. claims under workers' compensation, disability benefits, and other similar employee benefit acts.
  2. United States Longshoreman and Harbor Workers' Compensation Act and Jones Act coverage (if applicable).
  3. claims for damages because of bodily injury, occupational sickness or disease, or death of Contractor's employees (by stop-gap endorsement in monopolist worker's compensation states).
  4. Foreign voluntary worker compensation (if applicable).
- B. *Commercial General Liability—Claims Covered:* Contractor shall purchase and maintain commercial general liability insurance, covering all operations by or on behalf of Contractor, on an occurrence basis, against:
1. claims for damages because of bodily injury, sickness or disease, or death of any person other than Contractor's employees.
  2. claims for damages insured by reasonably available personal injury liability coverage.
  3. claims for damages, other than to the Work itself, because of injury to or destruction of tangible property wherever located, including loss of use resulting therefrom.
- C. *Commercial General Liability—Form and Content:* Contractor's commercial liability policy shall be written on a 1996 (or later) ISO commercial general liability form (occurrence form) and include the following coverages and endorsements:
1. Products and completed operations coverage:
    - a. Such insurance shall be maintained for three years after final payment.
    - b. Contractor shall furnish Owner and each other additional insured (as identified in the Supplementary Conditions or elsewhere in the Contract) evidence of continuation of such insurance at final payment and three years thereafter.
  2. Blanket contractual liability coverage, to the extent permitted by law, including but not limited to coverage of Contractor's contractual indemnity obligations in Paragraph 7.18.
  3. Broad form property damage coverage.
  4. Severability of interest.
  5. Underground, explosion, and collapse coverage.
  6. Personal injury coverage.
  7. Additional insured endorsements that include both ongoing operations and products and completed operations coverage through ISO Endorsements CG 20 10 10 01 and CG 20 37 10 01 (together); or CG 20 10 07 04 and CG 20 37 07 04 (together); or their equivalent.
  8. For design professional additional insureds, ISO Endorsement CG 20 32 07 04, "Additional Insured—Engineers, Architects or Surveyors Not Engaged by the Named Insured" or its equivalent.
- D. *Automobile liability:* Contractor shall purchase and maintain automobile liability insurance against claims for damages because of bodily injury or death of any person or property



damage arising out of the ownership, maintenance, or use of any motor vehicle. The automobile liability policy shall be written on an occurrence basis.

- E. *Umbrella or excess liability*: Contractor shall purchase and maintain umbrella or excess liability insurance written over the underlying employer's liability, commercial general liability, and automobile liability insurance described in the paragraphs above. Subject to industry-standard exclusions, the coverage afforded shall follow form as to each and every one of the underlying policies.
- F. ~~*Contractor's pollution liability insurance*: Contractor shall purchase and maintain a policy covering third-party injury and property damage claims, including clean-up costs, as a result of pollution conditions arising from Contractor's operations and completed operations. This insurance shall be maintained for no less than three years after final completion.~~
- G. *Additional insureds*: The Contractor's commercial general liability, automobile liability, umbrella or excess, and pollution liability policies shall include and list as additional insureds Owner and Engineer, and any individuals or entities identified in the Supplementary Conditions; include coverage for the respective officers, directors, members, partners, employees, agents, consultants, and subcontractors of each and any of all such additional insureds; and the insurance afforded to these additional insureds shall provide primary coverage for all claims covered thereby (including as applicable those arising from both ongoing and completed operations) on a non-contributory basis. Contractor shall obtain all necessary endorsements to support these requirements.
- H. *Contractor's professional liability insurance*: If Contractor will provide or furnish professional services under this Contract, through a delegation of professional design services or otherwise, then Contractor shall be responsible for purchasing and maintaining applicable professional liability insurance. This insurance shall provide protection against claims arising out of performance of professional design or related services, and caused by a negligent error, omission, or act for which the insured party is legally liable. It shall be maintained throughout the duration of the Contract and for a minimum of two years after Substantial Completion. If such professional design services are performed by a Subcontractor, and not by Contractor itself, then the requirements of this paragraph may be satisfied through the purchasing and maintenance of such insurance by such Subcontractor.
- I. *General provisions*: The policies of insurance required by this Paragraph 6.03 shall:
  - 1. include at least the specific coverages provided in this Article.
  - 2. be written for not less than the limits of liability provided in this Article and in the Supplementary Conditions, or required by Laws or Regulations, whichever is greater.
  - 3. contain a provision or endorsement that the coverage afforded will not be canceled, materially changed, or renewal refused until at least 10 days prior written notice has been given to Contractor. Within three days of receipt of any such written notice, Contractor shall provide a copy of the notice to Owner, Engineer, and each other insured under the policy.
  - 4. remain in effect at least until final payment (and longer if expressly required in this Article) and at all times thereafter when Contractor may be correcting, removing, or replacing defective Work as a warranty or correction obligation, or otherwise, or returning to the Site to conduct other tasks arising from the Contract Documents.

5. be appropriate for the Work being performed and provide protection from claims that may arise out of or result from Contractor's performance of the Work and Contractor's other obligations under the Contract Documents, whether it is to be performed by Contractor, any Subcontractor or Supplier, or by anyone directly or indirectly employed by any of them to perform any of the Work, or by anyone for whose acts any of them may be liable.
- J. The coverage requirements for specific policies of insurance must be met by such policies, and not by reference to excess or umbrella insurance provided in other policies.

#### 6.04 *Owner's Liability Insurance*

- A. In addition to the insurance required to be provided by Contractor under Paragraph 6.03, Owner, at Owner's option, may purchase and maintain at Owner's expense Owner's own liability insurance as will protect Owner against claims which may arise from operations under the Contract Documents.
- B. Owner's liability policies, if any, operate separately and independently from policies required to be provided by Contractor, and Contractor cannot rely upon Owner's liability policies for any of Contractor's obligations to the Owner, Engineer, or third parties.

#### 6.05 *Property Insurance*

- A. *Builder's Risk*: Unless otherwise provided in the Supplementary Conditions, Contractor shall purchase and maintain builder's risk insurance upon the Work on a completed value basis, in the amount of the full insurable replacement cost thereof (subject to such deductible amounts as may be provided in the Supplementary Conditions or required by Laws and Regulations). This insurance shall:
  1. include the Owner and Contractor as named insureds, and all Subcontractors, and any individuals or entities required by the Supplementary Conditions to be insured under such builder's risk policy, as insureds or named insureds. For purposes of the remainder of this Paragraph 6.05, Paragraphs 6.06 and 6.07, and any corresponding Supplementary Conditions, the parties required to be insured shall collectively be referred to as "insureds."
  2. be written on a builder's risk "all risk" policy form that shall at least include insurance for physical loss or damage to the Work, temporary buildings, falsework, and materials and equipment in transit, and shall insure against at least the following perils or causes of loss: fire; lightning; windstorm; riot; civil commotion; terrorism; vehicle impact; aircraft; smoke; theft; vandalism and malicious mischief; mechanical breakdown, boiler explosion, and artificially generated electric current; earthquake; volcanic activity, and other earth movement; flood; collapse; explosion; debris removal; demolition occasioned by enforcement of Laws and Regulations; water damage (other than that caused by flood); and such other perils or causes of loss as may be specifically required by the Supplementary Conditions. If insurance against mechanical breakdown, boiler explosion, and artificially generated electric current; earthquake; volcanic activity, and other earth movement; or flood, are not commercially available under builder's risk policies, by endorsement or otherwise, such insurance may be provided through other insurance policies acceptable to Owner and Contractor.
  3. cover, as insured property, at least the following: (a) the Work and all materials, supplies, machinery, apparatus, equipment, fixtures, and other property of a similar nature that are to be incorporated into or used in the preparation, fabrication, construction, erection, or completion of the Work, including Owner-furnished or assigned property; (b) spare parts

inventory required within the scope of the Contract; and (c) temporary works which are not intended to form part of the permanent constructed Work but which are intended to provide working access to the Site, or to the Work under construction, or which are intended to provide temporary support for the Work under construction, including scaffolding, form work, fences, shoring, falsework, and temporary structures.

4. cover expenses incurred in the repair or replacement of any insured property (including but not limited to fees and charges of engineers and architects).
  5. extend to cover damage or loss to insured property while in temporary storage at the Site or in a storage location outside the Site (but not including property stored at the premises of a manufacturer or Supplier).
  6. extend to cover damage or loss to insured property while in transit.
  7. allow for partial occupation or use of the Work by Owner, such that those portions of the Work that are not yet occupied or used by Owner shall remain covered by the builder's risk insurance.
  8. allow for the waiver of the insurer's subrogation rights, as set forth below.
  9. provide primary coverage for all losses and damages caused by the perils or causes of loss covered.
  10. not include a co-insurance clause.
  11. include an exception for ensuing losses from physical damage or loss with respect to any defective workmanship, design, or materials exclusions.
  12. include performance/hot testing and start-up.
  13. be maintained in effect, subject to the provisions herein regarding Substantial Completion and partial occupancy or use of the Work by Owner, until the Work is complete.
- B. *Notice of Cancellation or Change:* All the policies of insurance (and the certificates or other evidence thereof) required to be purchased and maintained in accordance with this Paragraph 6.05 will contain a provision or endorsement that the coverage afforded will not be canceled or materially changed or renewal refused until at least 10 days prior written notice has been given to the purchasing policyholder. Within three days of receipt of any such written notice, the purchasing policyholder shall provide a copy of the notice to each other insured.
- C. *Deductibles:* The purchaser of any required builder's risk or property insurance shall pay for costs not covered because of the application of a policy deductible.
- D. *Partial Occupancy or Use by Owner:* If Owner will occupy or use a portion or portions of the Work prior to Substantial Completion of all the Work as provided in Paragraph 15.04, then Owner (directly, if it is the purchaser of the builder's risk policy, or through Contractor) will provide notice of such occupancy or use to the builder's risk insurer. The builder's risk insurance shall not be canceled or permitted to lapse on account of any such partial use or occupancy; rather, those portions of the Work that are occupied or used by Owner may come off the builder's risk policy, while those portions of the Work not yet occupied or used by Owner shall remain covered by the builder's risk insurance.
- E. *Additional Insurance:* If Contractor elects to obtain other special insurance to be included in or supplement the builder's risk or property insurance policies provided under this Paragraph 6.05, it may do so at Contractor's expense.

- F. *Insurance of Other Property*: If the express insurance provisions of the Contract do not require or address the insurance of a property item or interest, such as tools, construction equipment, or other personal property owned by Contractor, a Subcontractor, or an employee of Contractor or a Subcontractor, then the entity or individual owning such property item will be responsible for deciding whether to insure it, and if so in what amount.

6.06 *Waiver of Rights*

- A. All policies purchased in accordance with Paragraph 6.05, expressly including the builder's risk policy, shall contain provisions to the effect that in the event of payment of any loss or damage the insurers will have no rights of recovery against any insureds thereunder, or against Engineer or its consultants, or their officers, directors, members, partners, employees, agents, consultants, or subcontractors. Owner and Contractor waive all rights against each other and the respective officers, directors, members, partners, employees, agents, consultants, and subcontractors of each and any of them, for all losses and damages caused by, arising out of, or resulting from any of the perils or causes of loss covered by such policies and any other property insurance applicable to the Work; and, in addition, waive all such rights against Engineer, its consultants, all Subcontractors, all individuals or entities identified in the Supplementary Conditions as insureds, and the officers, directors, members, partners, employees, agents, consultants, and subcontractors of each and any of them, under such policies for losses and damages so caused. None of the above waivers shall extend to the rights that any party making such waiver may have to the proceeds of insurance held by Owner or Contractor as trustee or fiduciary, or otherwise payable under any policy so issued.
- B. Owner waives all rights against Contractor, Subcontractors, and Engineer, and the officers, directors, members, partners, employees, agents, consultants and subcontractors of each and any of them, for:
1. loss due to business interruption, loss of use, or other consequential loss extending beyond direct physical loss or damage to Owner's property or the Work caused by, arising out of, or resulting from fire or other perils whether or not insured by Owner; and
  2. loss or damage to the completed Project or part thereof caused by, arising out of, or resulting from fire or other insured peril or cause of loss covered by any property insurance maintained on the completed Project or part thereof by Owner during partial occupancy or use pursuant to Paragraph 15.04, after Substantial Completion pursuant to Paragraph 15.03, or after final payment pursuant to Paragraph 15.06.
- C. Any insurance policy maintained by Owner covering any loss, damage or consequential loss referred to in Paragraph 6.06.B shall contain provisions to the effect that in the event of payment of any such loss, damage, or consequential loss, the insurers will have no rights of recovery against Contractor, Subcontractors, or Engineer, or the officers, directors, members, partners, employees, agents, consultants, or subcontractors of each and any of them.
- D. Contractor shall be responsible for assuring that the agreement under which a Subcontractor performs a portion of the Work contains provisions whereby the Subcontractor waives all rights against Owner, Contractor, all individuals or entities identified in the Supplementary Conditions as insureds, the Engineer and its consultants, and the officers, directors, members, partners, employees, agents, consultants, and subcontractors of each and any of them, for all losses and damages caused by, arising out of, relating to, or resulting from any of the perils or causes of loss covered by builder's risk insurance and any other property insurance applicable to the Work.

6.07 *Receipt and Application of Property Insurance Proceeds*

- A. Any insured loss under the builder's risk and other policies of insurance required by Paragraph 6.05 will be adjusted and settled with the named insured that purchased the policy. Such named insured shall act as fiduciary for the other insureds, and give notice to such other insureds that adjustment and settlement of a claim is in progress. Any other insured may state its position regarding a claim for insured loss in writing within 15 days after notice of such claim.
- B. Proceeds for such insured losses may be made payable by the insurer either jointly to multiple insureds, or to the named insured that purchased the policy in its own right and as fiduciary for other insureds, subject to the requirements of any applicable mortgage clause. A named insured receiving insurance proceeds under the builder's risk and other policies of insurance required by Paragraph 6.05 shall distribute such proceeds in accordance with such agreement as the parties in interest may reach, or as otherwise required under the dispute resolution provisions of this Contract or applicable Laws and Regulations.
- C. If no other special agreement is reached, the damaged Work shall be repaired or replaced, the money so received applied on account thereof, and the Work and the cost thereof covered by Change Order, if needed.

**ARTICLE 7 – CONTRACTOR'S RESPONSIBILITIES**

7.01 *Supervision and Superintendence*

- A. Contractor shall supervise, inspect, and direct the Work competently and efficiently, devoting such attention thereto and applying such skills and expertise as may be necessary to perform the Work in accordance with the Contract Documents. Contractor shall be solely responsible for the means, methods, techniques, sequences, and procedures of construction.
- B. At all times during the progress of the Work, Contractor shall assign a competent resident superintendent who shall not be replaced without written notice to Owner and Engineer except under extraordinary circumstances.

7.02 *Labor; Working Hours*

- A. Contractor shall provide competent, suitably qualified personnel to survey and lay out the Work and perform construction as required by the Contract Documents. Contractor shall at all times maintain good discipline and order at the Site.
- B. Except as otherwise required for the safety or protection of persons or the Work or property at the Site or adjacent thereto, and except as otherwise stated in the Contract Documents, all Work at the Site shall be performed during regular working hours, Monday through Friday. Contractor will not perform Work on a Saturday, Sunday, or any legal holiday. Contractor may perform Work outside regular working hours or on Saturdays, Sundays, or legal holidays only with Owner's written consent, which will not be unreasonably withheld.

7.03 *Services, Materials, and Equipment*

- A. Unless otherwise specified in the Contract Documents, Contractor shall provide and assume full responsibility for all services, materials, equipment, labor, transportation, construction equipment and machinery, tools, appliances, fuel, power, light, heat, telephone, water, sanitary facilities, temporary facilities, and all other facilities and incidentals necessary for the

performance, testing, start up, and completion of the Work, whether or not such items are specifically called for in the Contract Documents.

- B. All materials and equipment incorporated into the Work shall be of good quality and new, except as otherwise provided in the Contract Documents. All special warranties and guarantees required by the Specifications shall expressly run to the benefit of Owner. If required by Engineer, Contractor shall furnish satisfactory evidence (including reports of required tests) as to the source, kind, and quality of materials and equipment.
- C. All materials and equipment shall be stored, applied, installed, connected, erected, protected, used, cleaned, and conditioned in accordance with instructions of the applicable Supplier, except as otherwise may be provided in the Contract Documents.

#### 7.04 "Or Equals"

- A. Whenever an item of material or equipment is specified or described in the Contract Documents by using the name of a proprietary item or the name of a particular Supplier, the Contract Price has been based upon Contractor furnishing such item as specified. The specification or description of such an item is intended to establish the type, function, appearance, and quality required. Unless the specification or description contains or is followed by words reading that no like, equivalent, or "or equal" item is permitted, Contractor may request that Engineer authorize the use of other items of material or equipment, or items from other proposed suppliers under the circumstances described below.
  - 1. If Engineer in its sole discretion determines that an item of material or equipment proposed by Contractor is functionally equal to that named and sufficiently similar so that no change in related Work will be required, Engineer shall deem it an "or equal" item. For the purposes of this paragraph, a proposed item of material or equipment will be considered functionally equal to an item so named if:
    - a. in the exercise of reasonable judgment Engineer determines that:
      - 1) it is at least equal in materials of construction, quality, durability, appearance, strength, and design characteristics;
      - 2) it will reliably perform at least equally well the function and achieve the results imposed by the design concept of the completed Project as a functioning whole;
      - 3) it has a proven record of performance and availability of responsive service; and
      - 4) it is not objectionable to Owner.
    - b. Contractor certifies that, if approved and incorporated into the Work:
      - 1) there will be no increase in cost to the Owner or increase in Contract Times; and
      - 2) it will conform substantially to the detailed requirements of the item named in the Contract Documents.
  - B. *Contractor's Expense:* Contractor shall provide all data in support of any proposed "or equal" item at Contractor's expense.
  - C. *Engineer's Evaluation and Determination:* Engineer will be allowed a reasonable time to evaluate each "or-equal" request. Engineer may require Contractor to furnish additional data about the proposed "or-equal" item. Engineer will be the sole judge of acceptability. No "or-equal" item will be ordered, furnished, installed, or utilized until Engineer's review is complete

and Engineer determines that the proposed item is an “or-equal”, which will be evidenced by an approved Shop Drawing or other written communication. Engineer will advise Contractor in writing of any negative determination.

- D. *Effect of Engineer’s Determination:* Neither approval nor denial of an “or-equal” request shall result in any change in Contract Price. The Engineer’s denial of an “or-equal” request shall be final and binding, and may not be reversed through an appeal under any provision of the Contract Documents.
- E. *Treatment as a Substitution Request:* If Engineer determines that an item of material or equipment proposed by Contractor does not qualify as an “or-equal” item, Contractor may request that Engineer considered the proposed item as a substitute pursuant to Paragraph 7.05.

#### 7.05 Substitutes

- A. Unless the specification or description of an item of material or equipment required to be furnished under the Contract Documents contains or is followed by words reading that no substitution is permitted, Contractor may request that Engineer authorize the use of other items of material or equipment under the circumstances described below. To the extent possible such requests shall be made before commencement of related construction at the Site.
  - 1. Contractor shall submit sufficient information as provided below to allow Engineer to determine if the item of material or equipment proposed is functionally equivalent to that named and an acceptable substitute therefor. Engineer will not accept requests for review of proposed substitute items of material or equipment from anyone other than Contractor.
  - 2. The requirements for review by Engineer will be as set forth in Paragraph 7.05.B, as supplemented by the Specifications, and as Engineer may decide is appropriate under the circumstances.
  - 3. Contractor shall make written application to Engineer for review of a proposed substitute item of material or equipment that Contractor seeks to furnish or use. The application:
    - a. shall certify that the proposed substitute item will:
      - 1) perform adequately the functions and achieve the results called for by the general design,
      - 2) be similar in substance to that specified, and
      - 3) be suited to the same use as that specified.
    - b. will state:
      - 1) the extent, if any, to which the use of the proposed substitute item will necessitate a change in Contract Times,
      - 2) whether use of the proposed substitute item in the Work will require a change in any of the Contract Documents (or in the provisions of any other direct contract with Owner for other work on the Project) to adapt the design to the proposed substitute item, and
      - 3) whether incorporation or use of the proposed substitute item in connection with the Work is subject to payment of any license fee or royalty.

- c. will identify:
    - 1) all variations of the proposed substitute item from that specified, and
    - 2) available engineering, sales, maintenance, repair, and replacement services.
  - d. shall contain an itemized estimate of all costs or credits that will result directly or indirectly from use of such substitute item, including but not limited to changes in Contract Price, shared savings, costs of redesign, and claims of other contractors affected by any resulting change.
- B. *Engineer's Evaluation and Determination:* Engineer will be allowed a reasonable time to evaluate each substitute request, and to obtain comments and direction from Owner. Engineer may require Contractor to furnish additional data about the proposed substitute item. Engineer will be the sole judge of acceptability. No substitute will be ordered, furnished, installed, or utilized until Engineer's review is complete and Engineer determines that the proposed item is an acceptable substitute. Engineer's determination will be evidenced by a Field Order or a proposed Change Order accounting for the substitution itself and all related impacts, including changes in Contract Price or Contract Times. Engineer will advise Contractor in writing of any negative determination.
- C. *Special Guarantee:* Owner may require Contractor to furnish at Contractor's expense a special performance guarantee or other surety with respect to any substitute.
- D. *Reimbursement of Engineer's Cost:* Engineer will record Engineer's costs in evaluating a substitute proposed or submitted by Contractor. Whether or not Engineer approves a substitute so proposed or submitted by Contractor, Contractor shall reimburse Owner for the reasonable charges of Engineer for evaluating each such proposed substitute. Contractor shall also reimburse Owner for the reasonable charges of Engineer for making changes in the Contract Documents (or in the provisions of any other direct contract with Owner) resulting from the acceptance of each proposed substitute.
- E. *Contractor's Expense:* Contractor shall provide all data in support of any proposed substitute at Contractor's expense.
- F. *Effect of Engineer's Determination:* If Engineer approves the substitution request, Contractor shall execute the proposed Change Order and proceed with the substitution. The Engineer's denial of a substitution request shall be final and binding, and may not be reversed through an appeal under any provision of the Contract Documents. Contractor may challenge the scope of reimbursement costs imposed under Paragraph 7.05.D, by timely submittal of a Change Proposal.

#### 7.06 Concerning Subcontractors, Suppliers, and Others

- A. Contractor may retain Subcontractors and Suppliers for the performance of parts of the Work. Such Subcontractors and Suppliers must be acceptable to Owner.
- B. Contractor shall retain specific Subcontractors, Suppliers, or other individuals or entities for the performance of designated parts of the Work if required by the Contract to do so.
- C. Subsequent to the submittal of Contractor's Bid or final negotiation of the terms of the Contract, Owner may not require Contractor to retain any Subcontractor, Supplier, or other individual or entity to furnish or perform any of the Work against which Contractor has reasonable objection.



- D. Prior to entry into any binding subcontract or purchase order, Contractor shall submit to Owner the identity of the proposed Subcontractor or Supplier (unless Owner has already deemed such proposed Subcontractor or Supplier acceptable, during the bidding process or otherwise). Such proposed Subcontractor or Supplier shall be deemed acceptable to Owner unless Owner raises a substantive, reasonable objection within five days.
- E. Owner may require the replacement of any Subcontractor, Supplier, or other individual or entity retained by Contractor to perform any part of the Work. Owner also may require Contractor to retain specific replacements; provided, however, that Owner may not require a replacement to which Contractor has a reasonable objection. If Contractor has submitted the identity of certain Subcontractors, Suppliers, or other individuals or entities for acceptance by Owner, and Owner has accepted it (either in writing or by failing to make written objection thereto), then Owner may subsequently revoke the acceptance of any such Subcontractor, Supplier, or other individual or entity so identified solely on the basis of substantive, reasonable objection after due investigation. Contractor shall submit an acceptable replacement for the rejected Subcontractor, Supplier, or other individual or entity.
- F. If Owner requires the replacement of any Subcontractor, Supplier, or other individual or entity retained by Contractor to perform any part of the Work, then Contractor shall be entitled to an adjustment in Contract Price or Contract Times, or both, with respect to the replacement; and Contractor shall initiate a Change Proposal for such adjustment within 30 days of Owner's requirement of replacement.
- G. No acceptance by Owner of any such Subcontractor, Supplier, or other individual or entity, whether initially or as a replacement, shall constitute a waiver of the right of Owner to the completion of the Work in accordance with the Contract Documents.
- H. On a monthly basis Contractor shall submit to Engineer a complete list of all Subcontractors and Suppliers having a direct contract with Contractor, and of all other Subcontractors and Suppliers known to Contractor at the time of submittal.
- I. Contractor shall be fully responsible to Owner and Engineer for all acts and omissions of the Subcontractors, Suppliers, and other individuals or entities performing or furnishing any of the Work just as Contractor is responsible for Contractor's own acts and omissions.
- J. Contractor shall be solely responsible for scheduling and coordinating the work of Subcontractors, Suppliers, and all other individuals or entities performing or furnishing any of the Work.
- K. Contractor shall restrict all Subcontractors, Suppliers, and such other individuals or entities performing or furnishing any of the Work from communicating with Engineer or Owner, except through Contractor or in case of an emergency, or as otherwise expressly allowed herein.
- L. The divisions and sections of the Specifications and the identifications of any Drawings shall not control Contractor in dividing the Work among Subcontractors or Suppliers or delineating the Work to be performed by any specific trade.
- M. All Work performed for Contractor by a Subcontractor or Supplier shall be pursuant to an appropriate contractual agreement that specifically binds the Subcontractor or Supplier to the applicable terms and conditions of the Contract Documents for the benefit of Owner and Engineer.

- N. Owner may furnish to any Subcontractor or Supplier, to the extent practicable, information about amounts paid to Contractor on account of Work performed for Contractor by the particular Subcontractor or Supplier.
- O. Nothing in the Contract Documents:
  - 1. shall create for the benefit of any such Subcontractor, Supplier, or other individual or entity any contractual relationship between Owner or Engineer and any such Subcontractor, Supplier, or other individual or entity; nor
  - 2. shall create any obligation on the part of Owner or Engineer to pay or to see to the payment of any money due any such Subcontractor, Supplier, or other individual or entity except as may otherwise be required by Laws and Regulations.

#### 7.07 *Patent Fees and Royalties*

- A. Contractor shall pay all license fees and royalties and assume all costs incident to the use in the performance of the Work or the incorporation in the Work of any invention, design, process, product, or device which is the subject of patent rights or copyrights held by others. If a particular invention, design, process, product, or device is specified in the Contract Documents for use in the performance of the Work and if, to the actual knowledge of Owner or Engineer, its use is subject to patent rights or copyrights calling for the payment of any license fee or royalty to others, the existence of such rights shall be disclosed by Owner in the Contract Documents.
- B. To the fullest extent permitted by Laws and Regulations, Owner shall indemnify and hold harmless Contractor, and its officers, directors, members, partners, employees, agents, consultants, and subcontractors from and against all claims, costs, losses, and damages (including but not limited to all fees and charges of engineers, architects, attorneys, and other professionals, and all court or arbitration or other dispute resolution costs) arising out of or relating to any infringement of patent rights or copyrights incident to the use in the performance of the Work or resulting from the incorporation in the Work of any invention, design, process, product, or device specified in the Contract Documents, but not identified as being subject to payment of any license fee or royalty to others required by patent rights or copyrights.
- C. To the fullest extent permitted by Laws and Regulations, Contractor shall indemnify and hold harmless Owner and Engineer, and the officers, directors, members, partners, employees, agents, consultants and subcontractors of each and any of them from and against all claims, costs, losses, and damages (including but not limited to all fees and charges of engineers, architects, attorneys, and other professionals and all court or arbitration or other dispute resolution costs) arising out of or relating to any infringement of patent rights or copyrights incident to the use in the performance of the Work or resulting from the incorporation in the Work of any invention, design, process, product, or device not specified in the Contract Documents.

#### 7.08 *Permits*

- A. Unless otherwise provided in the Contract Documents, Contractor shall obtain and pay for all construction permits and licenses. Owner shall assist Contractor, when necessary, in obtaining such permits and licenses. Contractor shall pay all governmental charges and inspection fees necessary for the prosecution of the Work which are applicable at the time of the submission of Contractor's Bid (or when Contractor became bound under a negotiated contract). Owner

shall pay all charges of utility owners for connections for providing permanent service to the Work

7.09 *Taxes*

- A. Contractor shall pay all sales, consumer, use, and other similar taxes required to be paid by Contractor in accordance with the Laws and Regulations of the place of the Project which are applicable during the performance of the Work.

7.10 *Laws and Regulations*

- A. Contractor shall give all notices required by and shall comply with all Laws and Regulations applicable to the performance of the Work. Except where otherwise expressly required by applicable Laws and Regulations, neither Owner nor Engineer shall be responsible for monitoring Contractor's compliance with any Laws or Regulations.
- B. If Contractor performs any Work or takes any other action knowing or having reason to know that it is contrary to Laws or Regulations, Contractor shall bear all resulting costs and losses, and shall indemnify and hold harmless Owner and Engineer, and the officers, directors, members, partners, employees, agents, consultants, and subcontractors of each and any of them from and against all claims, costs, losses, and damages (including but not limited to all fees and charges of engineers, architects, attorneys, and other professionals and all court or arbitration or other dispute resolution costs) arising out of or relating to such Work or other action. It shall not be Contractor's responsibility to make certain that the Work described in the Contract Documents is in accordance with Laws and Regulations, but this shall not relieve Contractor of Contractor's obligations under Paragraph 3.03.
- C. Owner or Contractor may give notice to the other party of any changes after the submission of Contractor's Bid (or after the date when Contractor became bound under a negotiated contract) in Laws or Regulations having an effect on the cost or time of performance of the Work, including but not limited to changes in Laws or Regulations having an effect on procuring permits and on sales, use, value-added, consumption, and other similar taxes. If Owner and Contractor are unable to agree on entitlement to or on the amount or extent, if any, of any adjustment in Contract Price or Contract Times resulting from such changes, then within 30 days of such notice Contractor may submit a Change Proposal, or Owner may initiate a Claim.

7.11 *Record Documents*

- A. Contractor shall maintain in a safe place at the Site one printed record copy of all Drawings, Specifications, Addenda, Change Orders, Work Change Directives, Field Orders, written interpretations and clarifications, and approved Shop Drawings. Contractor shall keep such record documents in good order and annotate them to show changes made during construction. These record documents, together with all approved Samples, will be available to Engineer for reference. Upon completion of the Work, Contractor shall deliver these record documents to Engineer.

7.12 *Safety and Protection*

- A. Contractor shall be solely responsible for initiating, maintaining, and supervising all safety precautions and programs in connection with the Work. Such responsibility does not relieve Subcontractors of their responsibility for the safety of persons or property in the performance of their work, nor for compliance with applicable safety Laws and Regulations. Contractor

shall take all necessary precautions for the safety of, and shall provide the necessary protection to prevent damage, injury, or loss to:

1. all persons on the Site or who may be affected by the Work;
  2. all the Work and materials and equipment to be incorporated therein, whether in storage on or off the Site; and
  3. other property at the Site or adjacent thereto, including trees, shrubs, lawns, walks, pavements, roadways, structures, other work in progress, utilities, and Underground Facilities not designated for removal, relocation, or replacement in the course of construction.
- B. Contractor shall comply with all applicable Laws and Regulations relating to the safety of persons or property, or to the protection of persons or property from damage, injury, or loss; and shall erect and maintain all necessary safeguards for such safety and protection. Contractor shall notify Owner; the owners of adjacent property, Underground Facilities, and other utilities; and other contractors and utility owners performing work at or adjacent to the Site, when prosecution of the Work may affect them, and shall cooperate with them in the protection, removal, relocation, and replacement of their property or work in progress.
- C. Contractor shall comply with the applicable requirements of Owner's safety programs, if any. The Supplementary Conditions identify any Owner's safety programs that are applicable to the Work.
- D. Contractor shall inform Owner and Engineer of the specific requirements of Contractor's safety program with which Owner's and Engineer's employees and representatives must comply while at the Site.
- E. All damage, injury, or loss to any property referred to in Paragraph 7.12.A.2 or 7.12.A.3 caused, directly or indirectly, in whole or in part, by Contractor, any Subcontractor, Supplier, or any other individual or entity directly or indirectly employed by any of them to perform any of the Work, or anyone for whose acts any of them may be liable, shall be remedied by Contractor at its expense (except damage or loss attributable to the fault of Drawings or Specifications or to the acts or omissions of Owner or Engineer or anyone employed by any of them, or anyone for whose acts any of them may be liable, and not attributable, directly or indirectly, in whole or in part, to the fault or negligence of Contractor or any Subcontractor, Supplier, or other individual or entity directly or indirectly employed by any of them).
- F. Contractor's duties and responsibilities for safety and protection shall continue until such time as all the Work is completed and Engineer has issued a notice to Owner and Contractor in accordance with Paragraph 15.06.B that the Work is acceptable (except as otherwise expressly provided in connection with Substantial Completion).
- G. Contractor's duties and responsibilities for safety and protection shall resume whenever Contractor or any Subcontractor or Supplier returns to the Site to fulfill warranty or correction obligations, or to conduct other tasks arising from the Contract Documents.

### 7.13 *Safety Representative*

- A. Contractor shall designate a qualified and experienced safety representative at the Site whose duties and responsibilities shall be the prevention of accidents and the maintaining and supervising of safety precautions and programs.

7.14 *Hazard Communication Programs*

- A. Contractor shall be responsible for coordinating any exchange of material safety data sheets or other hazard communication information required to be made available to or exchanged between or among employers at the Site in accordance with Laws or Regulations.

7.15 *Emergencies*

- A. In emergencies affecting the safety or protection of persons or the Work or property at the Site or adjacent thereto, Contractor is obligated to act to prevent threatened damage, injury, or loss. Contractor shall give Engineer prompt written notice if Contractor believes that any significant changes in the Work or variations from the Contract Documents have been caused thereby or are required as a result thereof. If Engineer determines that a change in the Contract Documents is required because of the action taken by Contractor in response to such an emergency, a Work Change Directive or Change Order will be issued.

7.16 *Shop Drawings, Samples, and Other Submittals*

- A. Shop Drawing and Sample Submittal Requirements:
  - 1. Before submitting a Shop Drawing or Sample, Contractor shall have:
    - a. reviewed and coordinated the Shop Drawing or Sample with other Shop Drawings and Samples and with the requirements of the Work and the Contract Documents;
    - b. determined and verified all field measurements, quantities, dimensions, specified performance and design criteria, installation requirements, materials, catalog numbers, and similar information with respect thereto;
    - c. determined and verified the suitability of all materials and equipment offered with respect to the indicated application, fabrication, shipping, handling, storage, assembly, and installation pertaining to the performance of the Work; and
    - d. determined and verified all information relative to Contractor's responsibilities for means, methods, techniques, sequences, and procedures of construction, and safety precautions and programs incident thereto.
  - 2. Each submittal shall bear a stamp or specific written certification that Contractor has satisfied Contractor's obligations under the Contract Documents with respect to Contractor's review of that submittal, and that Contractor approves the submittal.
  - 3. With each submittal, Contractor shall give Engineer specific written notice of any variations that the Shop Drawing or Sample may have from the requirements of the Contract Documents. This notice shall be set forth in a written communication separate from the Shop Drawings or Sample submittal; and, in addition, in the case of Shop Drawings by a specific notation made on each Shop Drawing submitted to Engineer for review and approval of each such variation.
- B. *Submittal Procedures for Shop Drawings and Samples:* Contractor shall submit Shop Drawings and Samples to Engineer for review and approval in accordance with the accepted Schedule of Submittals. Each submittal will be identified as Engineer may require.
  - 1. Shop Drawings:
    - a. Contractor shall submit the number of copies required in the Specifications.

- b. Data shown on the Shop Drawings will be complete with respect to quantities, dimensions, specified performance and design criteria, materials, and similar data to show Engineer the services, materials, and equipment Contractor proposes to provide and to enable Engineer to review the information for the limited purposes required by Paragraph 7.16.D.
2. Samples:
  - a. Contractor shall submit the number of Samples required in the Specifications.
  - b. Contractor shall clearly identify each Sample as to material, Supplier, pertinent data such as catalog numbers, the use for which intended and other data as Engineer may require to enable Engineer to review the submittal for the limited purposes required by Paragraph 7.16.D.
3. Where a Shop Drawing or Sample is required by the Contract Documents or the Schedule of Submittals, any related Work performed prior to Engineer's review and approval of the pertinent submittal will be at the sole expense and responsibility of Contractor.
- C. *Other Submittals*: Contractor shall submit other submittals to Engineer in accordance with the accepted Schedule of Submittals, and pursuant to the applicable terms of the Specifications.
- D. Engineer's Review:
  1. Engineer will provide timely review of Shop Drawings and Samples in accordance with the Schedule of Submittals acceptable to Engineer. Engineer's review and approval will be only to determine if the items covered by the submittals will, after installation or incorporation in the Work, conform to the information given in the Contract Documents and be compatible with the design concept of the completed Project as a functioning whole as indicated by the Contract Documents.
  2. Engineer's review and approval will not extend to means, methods, techniques, sequences, or procedures of construction or to safety precautions or programs incident thereto.
  3. Engineer's review and approval of a separate item as such will not indicate approval of the assembly in which the item functions.
  4. Engineer's review and approval of a Shop Drawing or Sample shall not relieve Contractor from responsibility for any variation from the requirements of the Contract Documents unless Contractor has complied with the requirements of Paragraph 7.16.A.3 and Engineer has given written approval of each such variation by specific written notation thereof incorporated in or accompanying the Shop Drawing or Sample. Engineer will document any such approved variation from the requirements of the Contract Documents in a Field Order.
  5. Engineer's review and approval of a Shop Drawing or Sample shall not relieve Contractor from responsibility for complying with the requirements of Paragraph 7.16.A and B.
  6. Engineer's review and approval of a Shop Drawing or Sample, or of a variation from the requirements of the Contract Documents, shall not, under any circumstances, change the Contract Times or Contract Price, unless such changes are included in a Change Order.
  7. Neither Engineer's receipt, review, acceptance or approval of a Shop Drawing, Sample, or other submittal shall result in such item becoming a Contract Document.

8. Contractor shall perform the Work in compliance with the requirements and commitments set forth in approved Shop Drawings and Samples, subject to the provisions of Paragraph 7.16.D.4.
- E. Resubmittal Procedures:
1. Contractor shall make corrections required by Engineer and shall return the required number of corrected copies of Shop Drawings and submit, as required, new Samples for review and approval. Contractor shall direct specific attention in writing to revisions other than the corrections called for by Engineer on previous submittals.
  2. Contractor shall furnish required submittals with sufficient information and accuracy to obtain required approval of an item with no more than three submittals. Engineer will record Engineer's time for reviewing a fourth or subsequent submittal of a Shop Drawings, sample, or other item requiring approval, and Contractor shall be responsible for Engineer's charges to Owner for such time. Owner may impose a set-off against payments due to Contractor to secure reimbursement for such charges.
  3. If Contractor requests a change of a previously approved submittal item, Contractor shall be responsible for Engineer's charges to Owner for its review time, and Owner may impose a set-off against payments due to Contractor to secure reimbursement for such charges, unless the need for such change is beyond the control of Contractor.

#### 7.17 Contractor's General Warranty and Guarantee

- A. Contractor warrants and guarantees to Owner that all Work will be in accordance with the Contract Documents and will not be defective. Engineer and its officers, directors, members, partners, employees, agents, consultants, and subcontractors shall be entitled to rely on Contractor's warranty and guarantee.
- B. Contractor's warranty and guarantee hereunder excludes defects or damage caused by:
1. abuse, modification, or improper maintenance or operation by persons other than Contractor, Subcontractors, Suppliers, or any other individual or entity for whom Contractor is responsible; or
  2. normal wear and tear under normal usage.
- C. Contractor's obligation to perform and complete the Work in accordance with the Contract Documents shall be absolute. None of the following will constitute an acceptance of Work that is not in accordance with the Contract Documents or a release of Contractor's obligation to perform the Work in accordance with the Contract Documents:
1. observations by Engineer;
  2. recommendation by Engineer or payment by Owner of any progress or final payment;
  3. the issuance of a certificate of Substantial Completion by Engineer or any payment related thereto by Owner;
  4. use or occupancy of the Work or any part thereof by Owner;
  5. any review and approval of a Shop Drawing or Sample submittal;
  6. the issuance of a notice of acceptability by Engineer;
  7. any inspection, test, or approval by others; or

8. any correction of defective Work by Owner.
- D. If the Contract requires the Contractor to accept the assignment of a contract entered into by Owner, then the specific warranties, guarantees, and correction obligations contained in the assigned contract shall govern with respect to Contractor's performance obligations to Owner for the Work described in the assigned contract.

#### 7.18 *Indemnification*

- A. To the fullest extent permitted by Laws and Regulations, and in addition to any other obligations of Contractor under the Contract or otherwise, Contractor shall indemnify and hold harmless Owner and Engineer, and the officers, directors, members, partners, employees, agents, consultants and subcontractors of each and any of them from and against all claims, costs, losses, and damages (including but not limited to all fees and charges of engineers, architects, attorneys, and other professionals and all court or arbitration or other dispute resolution costs) arising out of or relating to the performance of the Work, provided that any such claim, cost, loss, or damage is attributable to bodily injury, sickness, disease, or death, or to injury to or destruction of tangible property (other than the Work itself), including the loss of use resulting therefrom but only to the extent caused by any negligent act or omission of Contractor, any Subcontractor, any Supplier, or any individual or entity directly or indirectly employed by any of them to perform any of the Work or anyone for whose acts any of them may be liable.
- B. In any and all claims against Owner or Engineer or any of their officers, directors, members, partners, employees, agents, consultants, or subcontractors by any employee (or the survivor or personal representative of such employee) of Contractor, any Subcontractor, any Supplier, or any individual or entity directly or indirectly employed by any of them to perform any of the Work, or anyone for whose acts any of them may be liable, the indemnification obligation under Paragraph 7.18.A shall not be limited in any way by any limitation on the amount or type of damages, compensation, or benefits payable by or for Contractor or any such Subcontractor, Supplier, or other individual or entity under workers' compensation acts, disability benefit acts, or other employee benefit acts.
- C. The indemnification obligations of Contractor under Paragraph 7.18.A shall not extend to the liability of Engineer and Engineer's officers, directors, members, partners, employees, agents, consultants and subcontractors arising out of:
  1. the preparation or approval of, or the failure to prepare or approve maps, Drawings, opinions, reports, surveys, Change Orders, designs, or Specifications; or
  2. giving directions or instructions, or failing to give them, if that is the primary cause of the injury or damage.

#### 7.19 *Delegation of Professional Design Services*

- A. Contractor will not be required to provide professional design services unless such services are specifically required by the Contract Documents for a portion of the Work or unless such services are required to carry out Contractor's responsibilities for construction means, methods, techniques, sequences and procedures. Contractor shall not be required to provide professional services in violation of applicable Laws and Regulations.
- B. If professional design services or certifications by a design professional related to systems, materials, or equipment are specifically required of Contractor by the Contract Documents,



Owner and Engineer will specify all performance and design criteria that such services must satisfy. Contractor shall cause such services or certifications to be provided by a properly licensed professional, whose signature and seal shall appear on all drawings, calculations, specifications, certifications, and other submittals prepared by such professional. Shop Drawings and other submittals related to the Work designed or certified by such professional, if prepared by others, shall bear such professional's written approval when submitted to Engineer.

- C. Owner and Engineer shall be entitled to rely upon the adequacy, accuracy, and completeness of the services, certifications, or approvals performed by such design professionals, provided Owner and Engineer have specified to Contractor all performance and design criteria that such services must satisfy.
- D. Pursuant to this paragraph, Engineer's review and approval of design calculations and design drawings will be only for the limited purpose of checking for conformance with performance and design criteria given and the design concept expressed in the Contract Documents. Engineer's review and approval of Shop Drawings and other submittals (except design calculations and design drawings) will be only for the purpose stated in Paragraph 7.16.D.1.
- E. Contractor shall not be responsible for the adequacy of the performance or design criteria specified by Owner or Engineer.

## **ARTICLE 8 – OTHER WORK AT THE SITE**

### **8.01 *Other Work***

- A. In addition to and apart from the Work under the Contract Documents, the Owner may perform other work at or adjacent to the Site. Such other work may be performed by Owner's employees, or through contracts between the Owner and third parties. Owner may also arrange to have third-party utility owners perform work on their utilities and facilities at or adjacent to the Site.
- B. If Owner performs other work at or adjacent to the Site with Owner's employees, or through contracts for such other work, then Owner shall give Contractor written notice thereof prior to starting any such other work. If Owner has advance information regarding the start of any utility work at or adjacent to the Site, Owner shall provide such information to Contractor.
- C. Contractor shall afford each other contractor that performs such other work, each utility owner performing other work, and Owner, if Owner is performing other work with Owner's employees, proper and safe access to the Site, and provide a reasonable opportunity for the introduction and storage of materials and equipment and the execution of such other work. Contractor shall do all cutting, fitting, and patching of the Work that may be required to properly connect or otherwise make its several parts come together and properly integrate with such other work. Contractor shall not endanger any work of others by cutting, excavating, or otherwise altering such work; provided, however, that Contractor may cut or alter others' work with the written consent of Engineer and the others whose work will be affected.
- D. If the proper execution or results of any part of Contractor's Work depends upon work performed by others under this Article 8, Contractor shall inspect such other work and promptly report to Engineer in writing any delays, defects, or deficiencies in such other work that render it unavailable or unsuitable for the proper execution and results of Contractor's Work. Contractor's failure to so report will constitute an acceptance of such other work as fit

and proper for integration with Contractor's Work except for latent defects and deficiencies in such other work.

#### 8.02 *Coordination*

- A. If Owner intends to contract with others for the performance of other work at or adjacent to the Site, to perform other work at or adjacent to the Site with Owner's employees, or to arrange to have utility owners perform work at or adjacent to the Site, the following will be set forth in the Supplementary Conditions or provided to Contractor prior to the start of any such other work:
  - 1. the identity of the individual or entity that will have authority and responsibility for coordination of the activities among the various contractors;
  - 2. an itemization of the specific matters to be covered by such authority and responsibility; and
  - 3. the extent of such authority and responsibilities.
- B. Unless otherwise provided in the Supplementary Conditions, Owner shall have sole authority and responsibility for such coordination.

#### 8.03 *Legal Relationships*

- A. If, in the course of performing other work at or adjacent to the Site for Owner, the Owner's employees, any other contractor working for Owner, or any utility owner for whom the Owner is responsible causes damage to the Work or to the property of Contractor or its Subcontractors, or delays, disrupts, interferes with, or increases the scope or cost of the performance of the Work, through actions or inaction, then Contractor shall be entitled to an equitable adjustment in the Contract Price or the Contract Times, or both. Contractor must submit any Change Proposal seeking an equitable adjustment in the Contract Price or the Contract Times under this paragraph within 30 days of the damaging, delaying, disrupting, or interfering event. The entitlement to, and extent of, any such equitable adjustment shall take into account information (if any) regarding such other work that was provided to Contractor in the Contract Documents prior to the submittal of the Bid or the final negotiation of the terms of the Contract. When applicable, any such equitable adjustment in Contract Price shall be conditioned on Contractor assigning to Owner all Contractor's rights against such other contractor or utility owner with respect to the damage, delay, disruption, or interference that is the subject of the adjustment. Contractor's entitlement to an adjustment of the Contract Times is conditioned on such adjustment being essential to Contractor's ability to complete the Work within the Contract Times.
- B. Contractor shall take reasonable and customary measures to avoid damaging, delaying, disrupting, or interfering with the work of Owner, any other contractor, or any utility owner performing other work at or adjacent to the Site. If Contractor fails to take such measures and as a result damages, delays, disrupts, or interferes with the work of any such other contractor or utility owner, then Owner may impose a set-off against payments due to Contractor, and assign to such other contractor or utility owner the Owner's contractual rights against Contractor with respect to the breach of the obligations set forth in this paragraph.
- C. When Owner is performing other work at or adjacent to the Site with Owner's employees, Contractor shall be liable to Owner for damage to such other work, and for the reasonable direct delay, disruption, and interference costs incurred by Owner as a result of Contractor's

failure to take reasonable and customary measures with respect to Owner's other work. In response to such damage, delay, disruption, or interference, Owner may impose a set-off against payments due to Contractor.

- D. If Contractor damages, delays, disrupts, or interferes with the work of any other contractor, or any utility owner performing other work at or adjacent to the Site, through Contractor's failure to take reasonable and customary measures to avoid such impacts, or if any claim arising out of Contractor's actions, inactions, or negligence in performance of the Work at or adjacent to the Site is made by any such other contractor or utility owner against Contractor, Owner, or Engineer, then Contractor shall (1) promptly attempt to settle the claim as to all parties through negotiations with such other contractor or utility owner, or otherwise resolve the claim by arbitration or other dispute resolution proceeding or at law, and (2) indemnify and hold harmless Owner and Engineer, and the officers, directors, members, partners, employees, agents, consultants and subcontractors of each and any of them from and against any such claims, and against all costs, losses, and damages (including but not limited to all fees and charges of engineers, architects, attorneys, and other professionals and all court or arbitration or other dispute resolution costs) arising out of or relating to such damage, delay, disruption, or interference.

## **ARTICLE 9 – OWNER'S RESPONSIBILITIES**

### **9.01 *Communications to Contractor***

- A. Except as otherwise provided in these General Conditions, Owner shall issue all communications to Contractor through Engineer.

### **9.02 *Replacement of Engineer***

- A. Owner may at its discretion appoint an engineer to replace Engineer, provided Contractor makes no reasonable objection to the replacement engineer. The replacement engineer's status under the Contract Documents shall be that of the former Engineer.

### **9.03 *Furnish Data***

- A. Owner shall promptly furnish the data required of Owner under the Contract Documents.

### **9.04 *Pay When Due***

- A. Owner shall make payments to Contractor when they are due as provided in the Agreement.

### **9.05 *Lands and Easements; Reports, Tests, and Drawings***

- A. Owner's duties with respect to providing lands and easements are set forth in Paragraph 5.01.  
B. Owner's duties with respect to providing engineering surveys to establish reference points are set forth in Paragraph 4.03.  
C. Article 5 refers to Owner's identifying and making available to Contractor copies of reports of explorations and tests of conditions at the Site, and drawings of physical conditions relating to existing surface or subsurface structures at the Site.

### **9.06 *Insurance***

- A. Owner's responsibilities, if any, with respect to purchasing and maintaining liability and property insurance are set forth in Article 6.

9.07 *Change Orders*

- A. Owner's responsibilities with respect to Change Orders are set forth in Article 11.

9.08 *Inspections, Tests, and Approvals*

- A. Owner's responsibility with respect to certain inspections, tests, and approvals is set forth in Paragraph 14.02.B.

9.09 *Limitations on Owner's Responsibilities*

- A. The Owner shall not supervise, direct, or have control or authority over, nor be responsible for, Contractor's means, methods, techniques, sequences, or procedures of construction, or the safety precautions and programs incident thereto, or for any failure of Contractor to comply with Laws and Regulations applicable to the performance of the Work. Owner will not be responsible for Contractor's failure to perform the Work in accordance with the Contract Documents.

9.10 *Undisclosed Hazardous Environmental Condition*

- A. Owner's responsibility in respect to an undisclosed Hazardous Environmental Condition is set forth in Paragraph 5.06.

9.11 *Evidence of Financial Arrangements*

- A. Upon request of Contractor, Owner shall furnish Contractor reasonable evidence that financial arrangements have been made to satisfy Owner's obligations under the Contract Documents (including obligations under proposed changes in the Work).

9.12 *Safety Programs*

- A. While at the Site, Owner's employees and representatives shall comply with the specific applicable requirements of Contractor's safety programs of which Owner has been informed.
- B. Owner shall furnish copies of any applicable Owner safety programs to Contractor.

**ARTICLE 10 – ENGINEER'S STATUS DURING CONSTRUCTION**

10.01 *Owner's Representative*

- A. Engineer will be Owner's representative during the construction period. The duties and responsibilities and the limitations of authority of Engineer as Owner's representative during construction are set forth in the Contract.

10.02 *Visits to Site*

- A. Engineer will make visits to the Site at intervals appropriate to the various stages of construction as Engineer deems necessary in order to observe as an experienced and qualified design professional the progress that has been made and the quality of the various aspects of Contractor's executed Work. Based on information obtained during such visits and observations, Engineer, for the benefit of Owner, will determine, in general, if the Work is proceeding in accordance with the Contract Documents. Engineer will not be required to make exhaustive or continuous inspections on the Site to check the quality or quantity of the Work. Engineer's efforts will be directed toward providing for Owner a greater degree of confidence that the completed Work will conform generally to the Contract Documents. On the basis of

such visits and observations, Engineer will keep Owner informed of the progress of the Work and will endeavor to guard Owner against defective Work.

- B. Engineer's visits and observations are subject to all the limitations on Engineer's authority and responsibility set forth in Paragraph 10.08. Particularly, but without limitation, during or as a result of Engineer's visits or observations of Contractor's Work, Engineer will not supervise, direct, control, or have authority over or be responsible for Contractor's means, methods, techniques, sequences, or procedures of construction, or the safety precautions and programs incident thereto, or for any failure of Contractor to comply with Laws and Regulations applicable to the performance of the Work.

#### 10.03 *Project Representative*

- A. If Owner and Engineer have agreed that Engineer will furnish a Resident Project Representative to represent Engineer at the Site and assist Engineer in observing the progress and quality of the Work, then the authority and responsibilities of any such Resident Project Representative will be as provided in the Supplementary Conditions, and limitations on the responsibilities thereof will be as provided in Paragraph 10.08. If Owner designates another representative or agent to represent Owner at the Site who is not Engineer's consultant, agent, or employee, the responsibilities and authority and limitations thereon of such other individual or entity will be as provided in the Supplementary Conditions.

#### 10.04 *Rejecting Defective Work*

- A. Engineer has the authority to reject Work in accordance with Article 14.

#### 10.05 *Shop Drawings, Change Orders and Payments*

- A. Engineer's authority, and limitations thereof, as to Shop Drawings and Samples, are set forth in Paragraph 7.16.
- B. Engineer's authority, and limitations thereof, as to design calculations and design drawings submitted in response to a delegation of professional design services, if any, are set forth in Paragraph 7.19.
- C. Engineer's authority as to Change Orders is set forth in Article 11.
- D. Engineer's authority as to Applications for Payment is set forth in Article 15.

#### 10.06 *Determinations for Unit Price Work*

- A. Engineer will determine the actual quantities and classifications of Unit Price Work performed by Contractor as set forth in Paragraph 13.03.

#### 10.07 *Decisions on Requirements of Contract Documents and Acceptability of Work*

- A. Engineer will render decisions regarding the requirements of the Contract Documents, and judge the acceptability of the Work, pursuant to the specific procedures set forth herein for initial interpretations, Change Proposals, and acceptance of the Work. In rendering such decisions and judgments, Engineer will not show partiality to Owner or Contractor, and will not be liable to Owner, Contractor, or others in connection with any proceedings, interpretations, decisions, or judgments conducted or rendered in good faith.

#### 10.08 *Limitations on Engineer's Authority and Responsibilities*

- A. Neither Engineer's authority or responsibility under this Article 10 or under any other provision of the Contract, nor any decision made by Engineer in good faith either to exercise

or not exercise such authority or responsibility or the undertaking, exercise, or performance of any authority or responsibility by Engineer, shall create, impose, or give rise to any duty in contract, tort, or otherwise owed by Engineer to Contractor, any Subcontractor, any Supplier, any other individual or entity, or to any surety for or employee or agent of any of them.

- B. Engineer will not supervise, direct, control, or have authority over or be responsible for Contractor's means, methods, techniques, sequences, or procedures of construction, or the safety precautions and programs incident thereto, or for any failure of Contractor to comply with Laws and Regulations applicable to the performance of the Work. Engineer will not be responsible for Contractor's failure to perform the Work in accordance with the Contract Documents.
- C. Engineer will not be responsible for the acts or omissions of Contractor or of any Subcontractor, any Supplier, or of any other individual or entity performing any of the Work.
- D. Engineer's review of the final Application for Payment and accompanying documentation and all maintenance and operating instructions, schedules, guarantees, bonds, certificates of inspection, tests and approvals, and other documentation required to be delivered by Paragraph 15.06.A will only be to determine generally that their content complies with the requirements of, and in the case of certificates of inspections, tests, and approvals, that the results certified indicate compliance with the Contract Documents.
- E. The limitations upon authority and responsibility set forth in this Paragraph 10.08 shall also apply to the Resident Project Representative, if any.

#### 10.09 *Compliance with Safety Program*

- A. While at the Site, Engineer's employees and representatives will comply with the specific applicable requirements of Owner's and Contractor's safety programs (if any) of which Engineer has been informed.

### **ARTICLE 11 – AMENDING THE CONTRACT DOCUMENTS; CHANGES IN THE WORK**

#### 11.01 *Amending and Supplementing Contract Documents*

- A. The Contract Documents may be amended or supplemented by a Change Order, a Work Change Directive, or a Field Order.
  - 1. Change Orders:
    - a. If an amendment or supplement to the Contract Documents includes a change in the Contract Price or the Contract Times, such amendment or supplement must be set forth in a Change Order. A Change Order also may be used to establish amendments and supplements of the Contract Documents that do not affect the Contract Price or Contract Times.
    - b. Owner and Contractor may amend those terms and conditions of the Contract Documents that do not involve (1) the performance or acceptability of the Work, (2) the design (as set forth in the Drawings, Specifications, or otherwise), or (3) other engineering or technical matters, without the recommendation of the Engineer. Such an amendment shall be set forth in a Change Order.
  - 2. *Work Change Directives*: A Work Change Directive will not change the Contract Price or the Contract Times but is evidence that the parties expect that the modification ordered or

documented by a Work Change Directive will be incorporated in a subsequently issued Change Order, following negotiations by the parties as to the Work Change Directive's effect, if any, on the Contract Price and Contract Times; or, if negotiations are unsuccessful, by a determination under the terms of the Contract Documents governing adjustments, expressly including Paragraph 11.04 regarding change of Contract Price. Contractor must submit any Change Proposal seeking an adjustment of the Contract Price or the Contract Times, or both, no later than 30 days after the completion of the Work set out in the Work Change Directive. Owner must submit any Claim seeking an adjustment of the Contract Price or the Contract Times, or both, no later than 60 days after issuance of the Work Change Directive.

3. *Field Orders*: Engineer may authorize minor changes in the Work if the changes do not involve an adjustment in the Contract Price or the Contract Times and are compatible with the design concept of the completed Project as a functioning whole as indicated by the Contract Documents. Such changes will be accomplished by a Field Order and will be binding on Owner and also on Contractor, which shall perform the Work involved promptly. If Contractor believes that a Field Order justifies an adjustment in the Contract Price or Contract Times, or both, then before proceeding with the Work at issue, Contractor shall submit a Change Proposal as provided herein.

#### 11.02 *Owner-Authorized Changes in the Work*

- A. Without invalidating the Contract and without notice to any surety, Owner may, at any time or from time to time, order additions, deletions, or revisions in the Work. Such changes shall be supported by Engineer's recommendation, to the extent the change involves the design (as set forth in the Drawings, Specifications, or otherwise), or other engineering or technical matters. Such changes may be accomplished by a Change Order, if Owner and Contractor have agreed as to the effect, if any, of the changes on Contract Times or Contract Price; or by a Work Change Directive. Upon receipt of any such document, Contractor shall promptly proceed with the Work involved; or, in the case of a deletion in the Work, promptly cease construction activities with respect to such deleted Work. Added or revised Work shall be performed under the applicable conditions of the Contract Documents. Nothing in this paragraph shall obligate Contractor to undertake work that Contractor reasonably concludes cannot be performed in a manner consistent with Contractor's safety obligations under the Contract Documents or Laws and Regulations.

#### 11.03 *Unauthorized Changes in the Work*

- A. Contractor shall not be entitled to an increase in the Contract Price or an extension of the Contract Times with respect to any work performed that is not required by the Contract Documents, as amended, modified, or supplemented, except in the case of an emergency as provided in Paragraph 7.15 or in the case of uncovering Work as provided in Paragraph 14.05.

#### 11.04 *Change of Contract Price*

- A. The Contract Price may only be changed by a Change Order. Any Change Proposal for an adjustment in the Contract Price shall comply with the provisions of Paragraph 11.06. Any Claim for an adjustment of Contract Price shall comply with the provisions of Article 12.
- B. An adjustment in the Contract Price will be determined as follows:

1. where the Work involved is covered by unit prices contained in the Contract Documents, then by application of such unit prices to the quantities of the items involved (subject to the provisions of Paragraph 13.03); or
  2. where the Work involved is not covered by unit prices contained in the Contract Documents, then by a mutually agreed lump sum (which may include an allowance for overhead and profit not necessarily in accordance with Paragraph 11.04.C.2); or
  3. where the Work involved is not covered by unit prices contained in the Contract Documents and the parties do not reach mutual agreement to a lump sum, then on the basis of the Cost of the Work (determined as provided in Paragraph 13.01) plus a Contractor's fee for overhead and profit (determined as provided in Paragraph 11.04.C).
- C. *Contractor's Fee:* When applicable, the Contractor's fee for overhead and profit shall be determined as follows:
1. a mutually acceptable fixed fee; or
  2. if a fixed fee is not agreed upon, then a fee based on the following percentages of the various portions of the Cost of the Work:
    - a. for costs incurred under Paragraphs 13.01.B.1 and 13.01.B.2, the Contractor's fee shall be 15 percent;
    - b. for costs incurred under Paragraph 13.01.B.3, the Contractor's fee shall be five percent;
    - c. where one or more tiers of subcontracts are on the basis of Cost of the Work plus a fee and no fixed fee is agreed upon, the intent of Paragraphs 11.04.C.2.a and 11.04.C.2.b is that the Contractor's fee shall be based on: (1) a fee of 15 percent of the costs incurred under Paragraphs 13.01.A.1 and 13.01.A.2 by the Subcontractor that actually performs the Work, at whatever tier, and (2) with respect to Contractor itself and to any Subcontractors of a tier higher than that of the Subcontractor that actually performs the Work, a fee of five percent of the amount (fee plus underlying costs incurred) attributable to the next lower tier Subcontractor; provided, however, that for any such subcontracted work the maximum total fee to be paid by Owner shall be no greater than 27 percent of the costs incurred by the Subcontractor that actually performs the work;
    - d. no fee shall be payable on the basis of costs itemized under Paragraphs 13.01.B.4, 13.01.B.5, and 13.01.C;
    - e. the amount of credit to be allowed by Contractor to Owner for any change which results in a net decrease in cost will be the amount of the actual net decrease in cost plus a deduction in Contractor's fee by an amount equal to five percent of such net decrease; and
    - f. when both additions and credits are involved in any one change, the adjustment in Contractor's fee shall be computed on the basis of the net change in accordance with Paragraphs 11.04.C.2.a through 11.04.C.2.e, inclusive.

#### 11.05 *Change of Contract Times*



- A. The Contract Times may only be changed by a Change Order. Any Change Proposal for an adjustment in the Contract Times shall comply with the provisions of Paragraph 11.06. Any Claim for an adjustment in the Contract Times shall comply with the provisions of Article 12.
- B. An adjustment of the Contract Times shall be subject to the limitations set forth in Paragraph 4.05, concerning delays in Contractor's progress.

#### 11.06 *Change Proposals*

- A. Contractor shall submit a Change Proposal to Engineer to request an adjustment in the Contract Times or Contract Price; appeal an initial decision by Engineer concerning the requirements of the Contract Documents or relating to the acceptability of the Work under the Contract Documents; contest a set-off against payment due; or seek other relief under the Contract. The Change Proposal shall specify any proposed change in Contract Times or Contract Price, or both, or other proposed relief, and explain the reason for the proposed change, with citations to any governing or applicable provisions of the Contract Documents.
  - 1. *Procedures:* Contractor shall submit each Change Proposal to Engineer promptly (but in no event later than 30 days) after the start of the event giving rise thereto, or after such initial decision. The Contractor shall submit supporting data, including the proposed change in Contract Price or Contract Time (if any), to the Engineer and Owner within 15 days after the submittal of the Change Proposal. The supporting data shall be accompanied by a written statement that the supporting data are accurate and complete, and that any requested time or price adjustment is the entire adjustment to which Contractor believes it is entitled as a result of said event. Engineer will advise Owner regarding the Change Proposal, and consider any comments or response from Owner regarding the Change Proposal.
  - 2. *Engineer's Action:* Engineer will review each Change Proposal and, within 30 days after receipt of the Contractor's supporting data, either deny the Change Proposal in whole, approve it in whole, or deny it in part and approve it in part. Such actions shall be in writing, with a copy provided to Owner and Contractor. If Engineer does not take action on the Change Proposal within 30 days, then either Owner or Contractor may at any time thereafter submit a letter to the other party indicating that as a result of Engineer's inaction the Change Proposal is deemed denied, thereby commencing the time for appeal of the denial under Article 12.
  - 3. *Binding Decision:* Engineer's decision will be final and binding upon Owner and Contractor, unless Owner or Contractor appeals the decision by filing a Claim under Article 12.
- B. *Resolution of Certain Change Proposals:* If the Change Proposal does not involve the design (as set forth in the Drawings, Specifications, or otherwise), the acceptability of the Work, or other engineering or technical matters, then Engineer will notify the parties that the Engineer is unable to resolve the Change Proposal. For purposes of further resolution of such a Change Proposal, such notice shall be deemed a denial, and Contractor may choose to seek resolution under the terms of Article 12.

#### 11.07 *Execution of Change Orders*

- A. Owner and Contractor shall execute appropriate Change Orders covering:

1. changes in the Contract Price or Contract Times which are agreed to by the parties, including any undisputed sum or amount of time for Work actually performed in accordance with a Work Change Directive;
  2. changes in Contract Price resulting from an Owner set-off, unless Contractor has duly contested such set-off;
  3. changes in the Work which are: (a) ordered by Owner pursuant to Paragraph 11.02, (b) required because of Owner's acceptance of defective Work under Paragraph 14.04 or Owner's correction of defective Work under Paragraph 14.07, or (c) agreed to by the parties, subject to the need for Engineer's recommendation if the change in the Work involves the design (as set forth in the Drawings, Specifications, or otherwise), or other engineering or technical matters; and
  4. changes in the Contract Price or Contract Times, or other changes, which embody the substance of any final and binding results under Paragraph 11.06, or Article 12.
- B. If Owner or Contractor refuses to execute a Change Order that is required to be executed under the terms of this Paragraph 11.07, it shall be deemed to be of full force and effect, as if fully executed.

#### 11.08 *Notification to Surety*

If the provisions of any bond require notice to be given to a surety of any change affecting the general scope of the Work or the provisions of the Contract Documents (including, but not limited to, Contract Price or Contract Times), the giving of any such notice will be Contractor's responsibility. The amount of each applicable bond will be adjusted to reflect the effect of any such change.

### ARTICLE 12 – CLAIMS

#### 12.01 *Claims*

- A. *Claims Process:* The following disputes between Owner and Contractor shall be submitted to the Claims process set forth in this Article:
1. Appeals by Owner or Contractor of Engineer's decisions regarding Change Proposals;
  2. Owner demands for adjustments in the Contract Price or Contract Times, or other relief under the Contract Documents; and
  3. Disputes that Engineer has been unable to address because they do not involve the design (as set forth in the Drawings, Specifications, or otherwise), the acceptability of the Work, or other engineering or technical matters.
- B. *Submittal of Claim:* The party submitting a Claim shall deliver it directly to the other party to the Contract promptly (but in no event later than 30 days) after the start of the event giving rise thereto; in the case of appeals regarding Change Proposals within 30 days of the decision under appeal. The party submitting the Claim shall also furnish a copy to the Engineer, for its information only. The responsibility to substantiate a Claim shall rest with the party making the Claim. In the case of a Claim by Contractor seeking an increase in the Contract Times or Contract Price, or both, Contractor shall certify that the Claim is made in good faith, that the supporting data are accurate and complete, and that to the best of Contractor's knowledge

and belief the amount of time or money requested accurately reflects the full amount to which Contractor is entitled.

- C. *Review and Resolution:* The party receiving a Claim shall review it thoroughly, giving full consideration to its merits. The two parties shall seek to resolve the Claim through the exchange of information and direct negotiations. The parties may extend the time for resolving the Claim by mutual agreement. All actions taken on a Claim shall be stated in writing and submitted to the other party, with a copy to Engineer.
- D. *Mediation:*
  - 1. At any time after initiation of a Claim, Owner and Contractor may mutually agree to mediation of the underlying dispute. The agreement to mediate shall stay the Claim submittal and response process.
  - 2. If Owner and Contractor agree to mediation, then after 60 days from such agreement, either Owner or Contractor may unilaterally terminate the mediation process, and the Claim submittal and decision process shall resume as of the date of the termination. If the mediation proceeds but is unsuccessful in resolving the dispute, the Claim submittal and decision process shall resume as of the date of the conclusion of the mediation, as determined by the mediator.
  - 3. Owner and Contractor shall each pay one-half of the mediator's fees and costs.
- E. *Partial Approval:* If the party receiving a Claim approves the Claim in part and denies it in part, such action shall be final and binding unless within 30 days of such action the other party invokes the procedure set forth in Article 17 for final resolution of disputes.
- F. *Denial of Claim:* If efforts to resolve a Claim are not successful, the party receiving the Claim may deny it by giving written notice of denial to the other party. If the receiving party does not take action on the Claim within 90 days, then either Owner or Contractor may at any time thereafter submit a letter to the other party indicating that as a result of the inaction, the Claim is deemed denied, thereby commencing the time for appeal of the denial. A denial of the Claim shall be final and binding unless within 30 days of the denial the other party invokes the procedure set forth in Article 17 for the final resolution of disputes.
- G. *Final and Binding Results:* If the parties reach a mutual agreement regarding a Claim, whether through approval of the Claim, direct negotiations, mediation, or otherwise; or if a Claim is approved in part and denied in part, or denied in full, and such actions become final and binding; then the results of the agreement or action on the Claim shall be incorporated in a Change Order to the extent they affect the Contract, including the Work, the Contract Times, or the Contract Price.

## ARTICLE 13 – COST OF THE WORK; ALLOWANCES; UNIT PRICE WORK

### 13.01 *Cost of the Work*

- A. *Purposes for Determination of Cost of the Work:* The term Cost of the Work means the sum of all costs necessary for the proper performance of the Work at issue, as further defined below. The provisions of this Paragraph 13.01 are used for two distinct purposes:
  - 1. To determine Cost of the Work when Cost of the Work is a component of the Contract Price, under cost-plus-fee, time-and-materials, or other cost-based terms; or

2. To determine the value of a Change Order, Change Proposal, Claim, set-off, or other adjustment in Contract Price. When the value of any such adjustment is determined on the basis of Cost of the Work, Contractor is entitled only to those additional or incremental costs required because of the change in the Work or because of the event giving rise to the adjustment.
- B. *Costs Included:* Except as otherwise may be agreed to in writing by Owner, costs included in the Cost of the Work shall be in amounts no higher than those prevailing in the locality of the Project, shall not include any of the costs itemized in Paragraph 13.01.C, and shall include only the following items:
1. Payroll costs for employees in the direct employ of Contractor in the performance of the Work under schedules of job classifications agreed upon by Owner and Contractor. Such employees shall include, without limitation, superintendents, foremen, and other personnel employed full time on the Work. Payroll costs for employees not employed full time on the Work shall be apportioned on the basis of their time spent on the Work. Payroll costs shall include, but not be limited to, salaries and wages plus the cost of fringe benefits, which shall include social security contributions, unemployment, excise, and payroll taxes, workers' compensation, health and retirement benefits, bonuses, sick leave, and vacation and holiday pay applicable thereto. The expenses of performing Work outside of regular working hours, on Saturday, Sunday, or legal holidays, shall be included in the above to the extent authorized by Owner.
  2. Cost of all materials and equipment furnished and incorporated in the Work, including costs of transportation and storage thereof, and Suppliers' field services required in connection therewith. All cash discounts shall accrue to Contractor unless Owner deposits funds with Contractor with which to make payments, in which case the cash discounts shall accrue to Owner. All trade discounts, rebates, and refunds and returns from sale of surplus materials and equipment shall accrue to Owner, and Contractor shall make provisions so that they may be obtained.
  3. Payments made by Contractor to Subcontractors for Work performed by Subcontractors. If required by Owner, Contractor shall obtain competitive bids from subcontractors acceptable to Owner and Contractor and shall deliver such bids to Owner, who will then determine, with the advice of Engineer, which bids, if any, will be acceptable. If any subcontract provides that the Subcontractor is to be paid on the basis of Cost of the Work plus a fee, the Subcontractor's Cost of the Work and fee shall be determined in the same manner as Contractor's Cost of the Work and fee as provided in this Paragraph 13.01.
  4. Costs of special consultants (including but not limited to engineers, architects, testing laboratories, surveyors, attorneys, and accountants) employed for services specifically related to the Work.
  5. Supplemental costs including the following:
    - a. The proportion of necessary transportation, travel, and subsistence expenses of Contractor's employees incurred in discharge of duties connected with the Work.
    - b. Cost, including transportation and maintenance, of all materials, supplies, equipment, machinery, appliances, office, and temporary facilities at the Site, and hand tools not owned by the workers, which are consumed in the performance of the Work, and cost,

less market value, of such items used but not consumed which remain the property of Contractor.

- c. Rentals of all construction equipment and machinery, and the parts thereof, whether rented from Contractor or others in accordance with rental agreements approved by Owner with the advice of Engineer, and the costs of transportation, loading, unloading, assembly, dismantling, and removal thereof. All such costs shall be in accordance with the terms of said rental agreements. The rental of any such equipment, machinery, or parts shall cease when the use thereof is no longer necessary for the Work.
  - d. Sales, consumer, use, and other similar taxes related to the Work, and for which Contractor is liable, as imposed by Laws and Regulations.
  - e. Deposits lost for causes other than negligence of Contractor, any Subcontractor, or anyone directly or indirectly employed by any of them or for whose acts any of them may be liable, and royalty payments and fees for permits and licenses.
  - f. Losses and damages (and related expenses) caused by damage to the Work, not compensated by insurance or otherwise, sustained by Contractor in connection with the performance of the Work (except losses and damages within the deductible amounts of property insurance established in accordance with Paragraph 6.05), provided such losses and damages have resulted from causes other than the negligence of Contractor, any Subcontractor, or anyone directly or indirectly employed by any of them or for whose acts any of them may be liable. Such losses shall include settlements made with the written consent and approval of Owner. No such losses, damages, and expenses shall be included in the Cost of the Work for the purpose of determining Contractor's fee.
  - g. The cost of utilities, fuel, and sanitary facilities at the Site.
  - h. Minor expenses such as communication service at the Site, express and courier services, and similar petty cash items in connection with the Work.
  - i. The costs of premiums for all bonds and insurance that Contractor is required by the Contract Documents to purchase and maintain.
- C. *Costs Excluded:* The term Cost of the Work shall not include any of the following items:
- 1. Payroll costs and other compensation of Contractor's officers, executives, principals (of partnerships and sole proprietorships), general managers, safety managers, engineers, architects, estimators, attorneys, auditors, accountants, purchasing and contracting agents, expeditors, timekeepers, clerks, and other personnel employed by Contractor, whether at the Site or in Contractor's principal or branch office for general administration of the Work and not specifically included in the agreed upon schedule of job classifications referred to in Paragraph 13.01.B.1 or specifically covered by Paragraph 13.01.B.4. The payroll costs and other compensation excluded here are to be considered administrative costs covered by the Contractor's fee.
  - 2. Expenses of Contractor's principal and branch offices other than Contractor's office at the Site.
  - 3. Any part of Contractor's capital expenses, including interest on Contractor's capital employed for the Work and charges against Contractor for delinquent payments.

4. Costs due to the negligence of Contractor, any Subcontractor, or anyone directly or indirectly employed by any of them or for whose acts any of them may be liable, including but not limited to, the correction of defective Work, disposal of materials or equipment wrongly supplied, and making good any damage to property.
  5. Other overhead or general expense costs of any kind and the costs of any item not specifically and expressly included in Paragraph 13.01.B.
- D. *Contractor's Fee:* When the Work as a whole is performed on the basis of cost-plus, Contractor's fee shall be determined as set forth in the Agreement. When the value of any Work covered by a Change Order, Change Proposal, Claim, set-off, or other adjustment in Contract Price is determined on the basis of Cost of the Work, Contractor's fee shall be determined as set forth in Paragraph 11.04.C.
- E. *Documentation:* Whenever the Cost of the Work for any purpose is to be determined pursuant to this Article 13, Contractor will establish and maintain records thereof in accordance with generally accepted accounting practices and submit in a form acceptable to Engineer an itemized cost breakdown together with supporting data.

#### 13.02 Allowances

- A. It is understood that Contractor has included in the Contract Price all allowances so named in the Contract Documents and shall cause the Work so covered to be performed for such sums and by such persons or entities as may be acceptable to Owner and Engineer.
- B. *Cash Allowances:* Contractor agrees that:
1. the cash allowances include the cost to Contractor (less any applicable trade discounts) of materials and equipment required by the allowances to be delivered at the Site, and all applicable taxes; and
  2. Contractor's costs for unloading and handling on the Site, labor, installation, overhead, profit, and other expenses contemplated for the cash allowances have been included in the Contract Price and not in the allowances, and no demand for additional payment on account of any of the foregoing will be valid.
- C. *Contingency Allowance:* Contractor agrees that a contingency allowance, if any, is for the sole use of Owner to cover unanticipated costs.
- D. Prior to final payment, an appropriate Change Order will be issued as recommended by Engineer to reflect actual amounts due Contractor on account of Work covered by allowances, and the Contract Price shall be correspondingly adjusted.

#### 13.03 Unit Price Work

- A. Where the Contract Documents provide that all or part of the Work is to be Unit Price Work, initially the Contract Price will be deemed to include for all Unit Price Work an amount equal to the sum of the unit price for each separately identified item of Unit Price Work times the estimated quantity of each item as indicated in the Agreement.
- B. The estimated quantities of items of Unit Price Work are not guaranteed and are solely for the purpose of comparison of Bids and determining an initial Contract Price. Payments to Contractor for Unit Price Work will be based on actual quantities.
- C. Each unit price will be deemed to include an amount considered by Contractor to be adequate to cover Contractor's overhead and profit for each separately identified item.

- D. Engineer will determine the actual quantities and classifications of Unit Price Work performed by Contractor. Engineer will review with Contractor the Engineer's preliminary determinations on such matters before rendering a written decision thereon (by recommendation of an Application for Payment or otherwise). Engineer's written decision thereon will be final and binding (except as modified by Engineer to reflect changed factual conditions or more accurate data) upon Owner and Contractor, subject to the provisions of the following paragraph.
- E. Within 30 days of Engineer's written decision under the preceding paragraph, Contractor may submit a Change Proposal, or Owner may file a Claim, seeking an adjustment in the Contract Price if:
  - 1. the quantity of any item of Unit Price Work performed by Contractor differs materially and significantly from the estimated quantity of such item indicated in the Agreement;
  - 2. there is no corresponding adjustment with respect to any other item of Work; and
  - 3. Contractor believes that it is entitled to an increase in Contract Price as a result of having incurred additional expense or Owner believes that Owner is entitled to a decrease in Contract Price, and the parties are unable to agree as to the amount of any such increase or decrease.

#### ARTICLE 14 – TESTS AND INSPECTIONS; CORRECTION, REMOVAL OR ACCEPTANCE OF DEFECTIVE WORK

##### 14.01 *Access to Work*

- A. Owner, Engineer, their consultants and other representatives and personnel of Owner, independent testing laboratories, and authorities having jurisdiction will have access to the Site and the Work at reasonable times for their observation, inspection, and testing. Contractor shall provide them proper and safe conditions for such access and advise them of Contractor's safety procedures and programs so that they may comply therewith as applicable.

##### 14.02 *Tests, Inspections, and Approvals*

- A. Contractor shall give Engineer timely notice of readiness of the Work (or specific parts thereof) for all required inspections and tests, and shall cooperate with inspection and testing personnel to facilitate required inspections and tests.
- B. ~~Owner~~ **Contractor** shall retain and pay for the services of an independent inspector, testing laboratory, or other qualified individual or entity to perform all inspections and tests expressly required by the Contract Documents to be furnished and paid for by ~~Owner~~ **Contractor**, except that costs incurred in connection with tests or inspections of covered Work shall be governed by the provisions of Paragraph 14.05.
- C. If Laws or Regulations of any public body having jurisdiction require any Work (or part thereof) specifically to be inspected, tested, or approved by an employee or other representative of such public body, Contractor shall assume full responsibility for arranging and obtaining such inspections, tests, or approvals, pay all costs in connection therewith, and furnish Engineer the required certificates of inspection or approval.
- D. Contractor shall be responsible for arranging, obtaining, and paying for all inspections and tests required:

1. by the Contract Documents, unless the Contract Documents expressly allocate responsibility for a specific inspection or test to Owner;
2. to attain Owner's and Engineer's acceptance of materials or equipment to be incorporated in the Work;
3. by manufacturers of equipment furnished under the Contract Documents;
4. for testing, adjusting, and balancing of mechanical, electrical, and other equipment to be incorporated into the Work; and
5. for acceptance of materials, mix designs, or equipment submitted for approval prior to Contractor's purchase thereof for incorporation in the Work.

Such inspections and tests shall be performed by independent inspectors, testing laboratories, or other qualified individuals or entities acceptable to Owner and Engineer.

- E. If the Contract Documents require the Work (or part thereof) to be approved by Owner, Engineer, or another designated individual or entity, then Contractor shall assume full responsibility for arranging and obtaining such approvals.
- F. If any Work (or the work of others) that is to be inspected, tested, or approved is covered by Contractor without written concurrence of Engineer, Contractor shall, if requested by Engineer, uncover such Work for observation. Such uncovering shall be at Contractor's expense unless Contractor had given Engineer timely notice of Contractor's intention to cover the same and Engineer had not acted with reasonable promptness in response to such notice.

#### 14.03 *Defective Work*

- A. *Contractor's Obligation:* It is Contractor's obligation to assure that the Work is not defective.
- B. *Engineer's Authority:* Engineer has the authority to determine whether Work is defective, and to reject defective Work.
- C. *Notice of Defects:* Prompt notice of all defective Work of which Owner or Engineer has actual knowledge will be given to Contractor.
- D. *Correction, or Removal and Replacement:* Promptly after receipt of written notice of defective Work, Contractor shall correct all such defective Work, whether or not fabricated, installed, or completed, or, if Engineer has rejected the defective Work, remove it from the Project and replace it with Work that is not defective.
- E. *Preservation of Warranties:* When correcting defective Work, Contractor shall take no action that would void or otherwise impair Owner's special warranty and guarantee, if any, on said Work.
- F. *Costs and Damages:* In addition to its correction, removal, and replacement obligations with respect to defective Work, Contractor shall pay all claims, costs, losses, and damages arising out of or relating to defective Work, including but not limited to the cost of the inspection, testing, correction, removal, replacement, or reconstruction of such defective Work, fines levied against Owner by governmental authorities because the Work is defective, and the costs of repair or replacement of work of others resulting from defective Work. Prior to final payment, if Owner and Contractor are unable to agree as to the measure of such claims, costs, losses, and damages resulting from defective Work, then Owner may impose a reasonable set-off against payments due under Article 15.



#### 14.04 *Acceptance of Defective Work*

- A. If, instead of requiring correction or removal and replacement of defective Work, Owner prefers to accept it, Owner may do so (subject, if such acceptance occurs prior to final payment, to Engineer's confirmation that such acceptance is in general accord with the design intent and applicable engineering principles, and will not endanger public safety). Contractor shall pay all claims, costs, losses, and damages attributable to Owner's evaluation of and determination to accept such defective Work (such costs to be approved by Engineer as to reasonableness), and for the diminished value of the Work to the extent not otherwise paid by Contractor. If any such acceptance occurs prior to final payment, the necessary revisions in the Contract Documents with respect to the Work shall be incorporated in a Change Order. If the parties are unable to agree as to the decrease in the Contract Price, reflecting the diminished value of Work so accepted, then Owner may impose a reasonable set-off against payments due under Article 15. If the acceptance of defective Work occurs after final payment, Contractor shall pay an appropriate amount to Owner.

#### 14.05 *Uncovering Work*

- A. Engineer has the authority to require additional inspection or testing of the Work, whether or not the Work is fabricated, installed, or completed.
- B. If any Work is covered contrary to the written request of Engineer, then Contractor shall, if requested by Engineer, uncover such Work for Engineer's observation, and then replace the covering, all at Contractor's expense.
- C. If Engineer considers it necessary or advisable that covered Work be observed by Engineer or inspected or tested by others, then Contractor, at Engineer's request, shall uncover, expose, or otherwise make available for observation, inspection, or testing as Engineer may require, that portion of the Work in question, and provide all necessary labor, material, and equipment.
  1. If it is found that the uncovered Work is defective, Contractor shall be responsible for all claims, costs, losses, and damages arising out of or relating to such uncovering, exposure, observation, inspection, and testing, and of satisfactory replacement or reconstruction (including but not limited to all costs of repair or replacement of work of others); and pending Contractor's full discharge of this responsibility the Owner shall be entitled to impose a reasonable set-off against payments due under Article 15.
  2. If the uncovered Work is not found to be defective, Contractor shall be allowed an increase in the Contract Price or an extension of the Contract Times, or both, directly attributable to such uncovering, exposure, observation, inspection, testing, replacement, and reconstruction. If the parties are unable to agree as to the amount or extent thereof, then Contractor may submit a Change Proposal within 30 days of the determination that the Work is not defective.

#### 14.06 *Owner May Stop the Work*

- A. If the Work is defective, or Contractor fails to supply sufficient skilled workers or suitable materials or equipment, or fails to perform the Work in such a way that the completed Work will conform to the Contract Documents, then Owner may order Contractor to stop the Work, or any portion thereof, until the cause for such order has been eliminated; however, this right of Owner to stop the Work shall not give rise to any duty on the part of Owner to exercise this

right for the benefit of Contractor, any Subcontractor, any Supplier, any other individual or entity, or any surety for, or employee or agent of any of them.

**14.07 Owner May Correct Defective Work**

- A. If Contractor fails within a reasonable time after written notice from Engineer to correct defective Work, or to remove and replace rejected Work as required by Engineer, or if Contractor fails to perform the Work in accordance with the Contract Documents, or if Contractor fails to comply with any other provision of the Contract Documents, then Owner may, after seven days written notice to Contractor, correct or remedy any such deficiency.
- B. In exercising the rights and remedies under this Paragraph 14.07, Owner shall proceed expeditiously. In connection with such corrective or remedial action, Owner may exclude Contractor from all or part of the Site, take possession of all or part of the Work and suspend Contractor's services related thereto, and incorporate in the Work all materials and equipment stored at the Site or for which Owner has paid Contractor but which are stored elsewhere. Contractor shall allow Owner, Owner's representatives, agents and employees, Owner's other contractors, and Engineer and Engineer's consultants access to the Site to enable Owner to exercise the rights and remedies under this paragraph.
- C. All claims, costs, losses, and damages incurred or sustained by Owner in exercising the rights and remedies under this Paragraph 14.07 will be charged against Contractor as set-offs against payments due under Article 15. Such claims, costs, losses and damages will include but not be limited to all costs of repair, or replacement of work of others destroyed or damaged by correction, removal, or replacement of Contractor's defective Work.
- D. Contractor shall not be allowed an extension of the Contract Times because of any delay in the performance of the Work attributable to the exercise by Owner of Owner's rights and remedies under this Paragraph 14.07.

**ARTICLE 15 – PAYMENTS TO CONTRACTOR; SET-OFFS; COMPLETION; CORRECTION PERIOD**

**15.01 Progress Payments**

- A. *Basis for Progress Payments:* The Schedule of Values established as provided in Article 2 will serve as the basis for progress payments and will be incorporated into a form of Application for Payment acceptable to Engineer. Progress payments on account of Unit Price Work will be based on the number of units completed during the pay period, as determined under the provisions of Paragraph 13.03. Progress payments for cost-based Work will be based on Cost of the Work completed by Contractor during the pay period.
- B. Applications for Payments:
  1. At least 20 days before the date established in the Agreement for each progress payment (but not more often than once a month), Contractor shall submit to Engineer for review an Application for Payment filled out and signed by Contractor covering the Work completed as of the date of the Application and accompanied by such supporting documentation as is required by the Contract Documents. If payment is requested on the basis of materials and equipment not incorporated in the Work but delivered and suitably stored at the Site or at another location agreed to in writing, the Application for Payment shall also be accompanied by a bill of sale, invoice, or other documentation warranting that Owner has received the materials and equipment free and clear of all Liens, and evidence that the

materials and equipment are covered by appropriate property insurance, a warehouse bond, or other arrangements to protect Owner's interest therein, all of which must be satisfactory to Owner.

2. Beginning with the second Application for Payment, each Application shall include an affidavit of Contractor stating that all previous progress payments received on account of the Work have been applied on account to discharge Contractor's legitimate obligations associated with prior Applications for Payment.
3. The amount of retainage with respect to progress payments will be as stipulated in the Agreement.

C. Review of Applications:

1. Engineer will, within 10 days after receipt of each Application for Payment, including each resubmittal, either indicate in writing a recommendation of payment and present the Application to Owner, or return the Application to Contractor indicating in writing Engineer's reasons for refusing to recommend payment. In the latter case, Contractor may make the necessary corrections and resubmit the Application.
2. Engineer's recommendation of any payment requested in an Application for Payment will constitute a representation by Engineer to Owner, based on Engineer's observations of the executed Work as an experienced and qualified design professional, and on Engineer's review of the Application for Payment and the accompanying data and schedules, that to the best of Engineer's knowledge, information and belief:
  - a. the Work has progressed to the point indicated;
  - b. the quality of the Work is generally in accordance with the Contract Documents (subject to an evaluation of the Work as a functioning whole prior to or upon Substantial Completion, the results of any subsequent tests called for in the Contract Documents, a final determination of quantities and classifications for Unit Price Work under Paragraph 13.03, and any other qualifications stated in the recommendation); and
  - c. the conditions precedent to Contractor's being entitled to such payment appear to have been fulfilled in so far as it is Engineer's responsibility to observe the Work.
3. By recommending any such payment Engineer will not thereby be deemed to have represented that:
  - a. inspections made to check the quality or the quantity of the Work as it has been performed have been exhaustive, extended to every aspect of the Work in progress, or involved detailed inspections of the Work beyond the responsibilities specifically assigned to Engineer in the Contract; or
  - b. there may not be other matters or issues between the parties that might entitle Contractor to be paid additionally by Owner or entitle Owner to withhold payment to Contractor.
4. Neither Engineer's review of Contractor's Work for the purposes of recommending payments nor Engineer's recommendation of any payment, including final payment, will impose responsibility on Engineer:
  - a. to supervise, direct, or control the Work, or

- b. for the means, methods, techniques, sequences, or procedures of construction, or the safety precautions and programs incident thereto, or
        - c. for Contractor's failure to comply with Laws and Regulations applicable to Contractor's performance of the Work, or
        - d. to make any examination to ascertain how or for what purposes Contractor has used the money paid on account of the Contract Price, or
        - e. to determine that title to any of the Work, materials, or equipment has passed to Owner free and clear of any Liens.
  5. Engineer may refuse to recommend the whole or any part of any payment if, in Engineer's opinion, it would be incorrect to make the representations to Owner stated in Paragraph 15.01.C.2.
  6. Engineer will recommend reductions in payment (set-offs) necessary in Engineer's opinion to protect Owner from loss because:
    - a. the Work is defective, requiring correction or replacement;
    - b. the Contract Price has been reduced by Change Orders;
    - c. Owner has been required to correct defective Work in accordance with Paragraph 14.07, or has accepted defective Work pursuant to Paragraph 14.04;
    - d. Owner has been required to remove or remediate a Hazardous Environmental Condition for which Contractor is responsible; or
    - e. Engineer has actual knowledge of the occurrence of any of the events that would constitute a default by Contractor and therefore justify termination for cause under the Contract Documents.
- D. Payment Becomes Due:
1. Thirty days after presentation of the Application for Payment to Owner with Engineer's recommendation, the amount recommended (subject to any Owner set-offs) will become due, and when due will be paid by Owner to Contractor.
- E. Reductions in Payment by Owner:
1. In addition to any reductions in payment (set-offs) recommended by Engineer, Owner is entitled to impose a set-off against payment based on any of the following:
    - a. claims have been made against Owner on account of Contractor's conduct in the performance or furnishing of the Work, or Owner has incurred costs, losses, or damages on account of Contractor's conduct in the performance or furnishing of the Work, including but not limited to claims, costs, losses, or damages from workplace injuries, adjacent property damage, non-compliance with Laws and Regulations, and patent infringement;
    - b. Contractor has failed to take reasonable and customary measures to avoid damage, delay, disruption, and interference with other work at or adjacent to the Site;
    - c. Contractor has failed to provide and maintain required bonds or insurance;
    - d. Owner has been required to remove or remediate a Hazardous Environmental Condition for which Contractor is responsible;

- e. Owner has incurred extra charges or engineering costs related to submittal reviews, evaluations of proposed substitutes, tests and inspections, or return visits to manufacturing or assembly facilities;
  - f. the Work is defective, requiring correction or replacement;
  - g. Owner has been required to correct defective Work in accordance with Paragraph 14.07, or has accepted defective Work pursuant to Paragraph 14.04;
  - h. the Contract Price has been reduced by Change Orders;
  - i. an event that would constitute a default by Contractor and therefore justify a termination for cause has occurred;
  - j. liquidated damages have accrued as a result of Contractor's failure to achieve Milestones, Substantial Completion, or final completion of the Work;
  - k. Liens have been filed in connection with the Work, except where Contractor has delivered a specific bond satisfactory to Owner to secure the satisfaction and discharge of such Liens;
  - l. there are other items entitling Owner to a set off against the amount recommended.
2. If Owner imposes any set-off against payment, whether based on its own knowledge or on the written recommendations of Engineer, Owner will give Contractor immediate written notice (with a copy to Engineer) stating the reasons for such action and the specific amount of the reduction, and promptly pay Contractor any amount remaining after deduction of the amount so withheld. Owner shall promptly pay Contractor the amount so withheld, or any adjustment thereto agreed to by Owner and Contractor, if Contractor remedies the reasons for such action. The reduction imposed shall be binding on Contractor unless it duly submits a Change Proposal contesting the reduction.
  3. Upon a subsequent determination that Owner's refusal of payment was not justified, the amount wrongfully withheld shall be treated as an amount due as determined by Paragraph 15.01.C.1 and subject to interest as provided in the Agreement.

#### 15.02 *Contractor's Warranty of Title*

- A. Contractor warrants and guarantees that title to all Work, materials, and equipment furnished under the Contract will pass to Owner free and clear of (1) all Liens and other title defects, and (2) all patent, licensing, copyright, or royalty obligations, no later than seven days after the time of payment by Owner.

#### 15.03 *Substantial Completion*

- A. When Contractor considers the entire Work ready for its intended use Contractor shall notify Owner and Engineer in writing that the entire Work is substantially complete and request that Engineer issue a certificate of Substantial Completion. Contractor shall at the same time submit to Owner and Engineer an initial draft of punch list items to be completed or corrected before final payment.
- B. Promptly after Contractor's notification, Owner, Contractor, and Engineer shall make an inspection of the Work to determine the status of completion. If Engineer does not consider the Work substantially complete, Engineer will notify Contractor in writing giving the reasons therefor.

- C. If Engineer considers the Work substantially complete, Engineer will deliver to Owner a preliminary certificate of Substantial Completion which shall fix the date of Substantial Completion. Engineer shall attach to the certificate a punch list of items to be completed or corrected before final payment. Owner shall have seven days after receipt of the preliminary certificate during which to make written objection to Engineer as to any provisions of the certificate or attached punch list. If, after considering the objections to the provisions of the preliminary certificate, Engineer concludes that the Work is not substantially complete, Engineer will, within 14 days after submission of the preliminary certificate to Owner, notify Contractor in writing that the Work is not substantially complete, stating the reasons therefor. If Owner does not object to the provisions of the certificate, or if despite consideration of Owner's objections Engineer concludes that the Work is substantially complete, then Engineer will, within said 14 days, execute and deliver to Owner and Contractor a final certificate of Substantial Completion (with a revised punch list of items to be completed or corrected) reflecting such changes from the preliminary certificate as Engineer believes justified after consideration of any objections from Owner.
- D. At the time of receipt of the preliminary certificate of Substantial Completion, Owner and Contractor will confer regarding Owner's use or occupancy of the Work following Substantial Completion, review the builder's risk insurance policy with respect to the end of the builder's risk coverage, and confirm the transition to coverage of the Work under a permanent property insurance policy held by Owner. Unless Owner and Contractor agree otherwise in writing, Owner shall bear responsibility for security, operation, protection of the Work, property insurance, maintenance, heat, and utilities upon Owner's use or occupancy of the Work.
- E. After Substantial Completion the Contractor shall promptly begin work on the punch list of items to be completed or corrected prior to final payment. In appropriate cases Contractor may submit monthly Applications for Payment for completed punch list items, following the progress payment procedures set forth above.
- F. Owner shall have the right to exclude Contractor from the Site after the date of Substantial Completion subject to allowing Contractor reasonable access to remove its property and complete or correct items on the punch list.

#### 15.04 *Partial Use or Occupancy*

- A. Prior to Substantial Completion of all the Work, Owner may use or occupy any substantially completed part of the Work which has specifically been identified in the Contract Documents, or which Owner, Engineer, and Contractor agree constitutes a separately functioning and usable part of the Work that can be used by Owner for its intended purpose without significant interference with Contractor's performance of the remainder of the Work, subject to the following conditions:
  - 1. At any time Owner may request in writing that Contractor permit Owner to use or occupy any such part of the Work that Owner believes to be substantially complete. If and when Contractor agrees that such part of the Work is substantially complete, Contractor, Owner, and Engineer will follow the procedures of Paragraph 15.03.A through E for that part of the Work.
  - 2. At any time Contractor may notify Owner and Engineer in writing that Contractor considers any such part of the Work substantially complete and request Engineer to issue a certificate of Substantial Completion for that part of the Work.

3. Within a reasonable time after either such request, Owner, Contractor, and Engineer shall make an inspection of that part of the Work to determine its status of completion. If Engineer does not consider that part of the Work to be substantially complete, Engineer will notify Owner and Contractor in writing giving the reasons therefor. If Engineer considers that part of the Work to be substantially complete, the provisions of Paragraph 15.03 will apply with respect to certification of Substantial Completion of that part of the Work and the division of responsibility in respect thereof and access thereto.
4. No use or occupancy or separate operation of part of the Work may occur prior to compliance with the requirements of Paragraph 6.05 regarding builder's risk or other property insurance.

**15.05 Final Inspection**

- A. Upon written notice from Contractor that the entire Work or an agreed portion thereof is complete, Engineer will promptly make a final inspection with Owner and Contractor and will notify Contractor in writing of all particulars in which this inspection reveals that the Work, or agreed portion thereof, is incomplete or defective. Contractor shall immediately take such measures as are necessary to complete such Work or remedy such deficiencies.

**15.06 Final Payment**

- A. Application for Payment:
  1. After Contractor has, in the opinion of Engineer, satisfactorily completed all corrections identified during the final inspection and has delivered, in accordance with the Contract Documents, all maintenance and operating instructions, schedules, guarantees, bonds, certificates or other evidence of insurance, certificates of inspection, annotated record documents (as provided in Paragraph 7.11), and other documents, Contractor may make application for final payment.
  2. The final Application for Payment shall be accompanied (except as previously delivered) by:
    - a. all documentation called for in the Contract Documents;
    - b. consent of the surety, if any, to final payment;
    - c. satisfactory evidence that all title issues have been resolved such that title to all Work, materials, and equipment has passed to Owner free and clear of any Liens or other title defects, or will so pass upon final payment.
    - d. a list of all disputes that Contractor believes are unsettled; and
    - e. complete and legally effective releases or waivers (satisfactory to Owner) of all Lien rights arising out of the Work, and of Liens filed in connection with the Work.
  3. In lieu of the releases or waivers of Liens specified in Paragraph 15.06.A.2 and as approved by Owner, Contractor may furnish receipts or releases in full and an affidavit of Contractor that: (a) the releases and receipts include all labor, services, material, and equipment for which a Lien could be filed; and (b) all payrolls, material and equipment bills, and other indebtedness connected with the Work for which Owner might in any way be responsible, or which might in any way result in liens or other burdens on Owner's property, have been paid or otherwise satisfied. If any Subcontractor or Supplier fails to furnish such a release or receipt in full, Contractor may furnish a bond or other collateral satisfactory to Owner to

indemnify Owner against any Lien, or Owner at its option may issue joint checks payable to Contractor and specified Subcontractors and Suppliers.

B. Engineer's Review of Application and Acceptance:

49. If, on the basis of Engineer's observation of the Work during construction and final inspection, and Engineer's review of the final Application for Payment and accompanying documentation as required by the Contract Documents, Engineer is satisfied that the Work has been completed and Contractor's other obligations under the Contract have been fulfilled, Engineer will, within ten days after receipt of the final Application for Payment, indicate in writing Engineer's recommendation of final payment and present the Application for Payment to Owner for payment. Such recommendation shall account for any set-offs against payment that are necessary in Engineer's opinion to protect Owner from loss for the reasons stated above with respect to progress payments. At the same time Engineer will also give written notice to Owner and Contractor that the Work is acceptable, subject to the provisions of Paragraph 15.07. Otherwise, Engineer will return the Application for Payment to Contractor, indicating in writing the reasons for refusing to recommend final payment, in which case Contractor shall make the necessary corrections and resubmit the Application for Payment.

C. *Completion of Work*: The Work is complete (subject to surviving obligations) when it is ready for final payment as established by the Engineer's written recommendation of final payment.

D. *Payment Becomes Due*: Thirty days after the presentation to Owner of the final Application for Payment and accompanying documentation, the amount recommended by Engineer (less any further sum Owner is entitled to set off against Engineer's recommendation, including but not limited to set-offs for liquidated damages and set-offs allowed under the provisions above with respect to progress payments) will become due and shall be paid by Owner to Contractor.

15.07 *Waiver of Claims*

A. The making of final payment will not constitute a waiver by Owner of claims or rights against Contractor. Owner expressly reserves claims and rights arising from unsettled Liens, from defective Work appearing after final inspection pursuant to Paragraph 15.05, from Contractor's failure to comply with the Contract Documents or the terms of any special guarantees specified therein, from outstanding Claims by Owner, or from Contractor's continuing obligations under the Contract Documents.

The acceptance of final payment by Contractor will constitute a waiver by Contractor of all claims and rights against Owner other than those pending matters that have been duly submitted or appealed under the provisions of Article 17.

15.08 *Correction Period*

A. If within one year after the date of Substantial Completion (or such longer period of time as may be prescribed by the terms of any applicable special guarantee required by the Contract Documents, or by any specific provision of the Contract Documents), any Work is found to be defective, or if the repair of any damages to the Site, adjacent areas that Contractor has arranged to use through construction easements or otherwise, and other adjacent areas used by Contractor as permitted by Laws and Regulations, is found to be defective, then Contractor shall promptly, without cost to Owner and in accordance with Owner's written instructions:

50. correct the defective repairs to the Site or such other adjacent areas;



51. correct such defective Work;
  52. if the defective Work has been rejected by Owner, remove it from the Project and replace it with Work that is not defective, and
  53. satisfactorily correct or repair or remove and replace any damage to other Work, to the work of others, or to other land or areas resulting therefrom.
- B. If Contractor does not promptly comply with the terms of Owner’s written instructions, or in an emergency where delay would cause serious risk of loss or damage, Owner may have the defective Work corrected or repaired or may have the rejected Work removed and replaced. Contractor shall pay all claims, costs, losses, and damages (including but not limited to all fees and charges of engineers, architects, attorneys, and other professionals and all court or arbitration or other dispute resolution costs) arising out of or relating to such correction or repair or such removal and replacement (including but not limited to all costs of repair or replacement of work of others).
- C. In special circumstances where a particular item of equipment is placed in continuous service before Substantial Completion of all the Work, the correction period for that item may start to run from an earlier date if so provided in the Specifications.
- D. Where defective Work (and damage to other Work resulting therefrom) has been corrected or removed and replaced under this paragraph, the correction period hereunder with respect to such Work will be extended for an additional period of one year after such correction or removal and replacement has been satisfactorily completed.
- E. Contractor’s obligations under this paragraph are in addition to all other obligations and warranties. The provisions of this paragraph shall not be construed as a substitute for, or a waiver of, the provisions of any applicable statute of limitation or repose.

## **ARTICLE 16 – SUSPENSION OF WORK AND TERMINATION**

### **16.01 *Owner May Suspend Work***

- A. At any time and without cause, Owner may suspend the Work or any portion thereof for a period of not more than 90 consecutive days by written notice to Contractor and Engineer. Such notice will fix the date on which Work will be resumed. Contractor shall resume the Work on the date so fixed. Contractor shall be entitled to an adjustment in the Contract Price or an extension of the Contract Times, or both, directly attributable to any such suspension. Any Change Proposal seeking such adjustments shall be submitted no later than 30 days after the date fixed for resumption of Work.

### **16.02 *Owner May Terminate for Cause***

- A. The occurrence of any one or more of the following events will constitute a default by Contractor and justify termination for cause:
54. Contractor’s persistent failure to perform the Work in accordance with the Contract Documents (including, but not limited to, failure to supply sufficient skilled workers or suitable materials or equipment or failure to adhere to the Progress Schedule);
  55. Failure of Contractor to perform or otherwise to comply with a material term of the Contract Documents;

- 56. Contractor's disregard of Laws or Regulations of any public body having jurisdiction; or
- 57. Contractor's repeated disregard of the authority of Owner or Engineer.
- B. If one or more of the events identified in Paragraph 16.02.A occurs, then after giving Contractor (and any surety) ten days written notice that Owner is considering a declaration that Contractor is in default and termination of the contract, Owner may proceed to:
  - 58. declare Contractor to be in default, and give Contractor (and any surety) notice that the Contract is terminated; and
  - 59. enforce the rights available to Owner under any applicable performance bond.
- C. Subject to the terms and operation of any applicable performance bond, if Owner has terminated the Contract for cause, Owner may exclude Contractor from the Site, take possession of the Work, incorporate in the Work all materials and equipment stored at the Site or for which Owner has paid Contractor but which are stored elsewhere, and complete the Work as Owner may deem expedient.
- D. Owner may not proceed with termination of the Contract under Paragraph 16.02.B if Contractor within seven days of receipt of notice of intent to terminate begins to correct its failure to perform and proceeds diligently to cure such failure.
- E. If Owner proceeds as provided in Paragraph 16.02.B, Contractor shall not be entitled to receive any further payment until the Work is completed. If the unpaid balance of the Contract Price exceeds the cost to complete the Work, including all related claims, costs, losses, and damages (including but not limited to all fees and charges of engineers, architects, attorneys, and other professionals) sustained by Owner, such excess will be paid to Contractor. If the cost to complete the Work including such related claims, costs, losses, and damages exceeds such unpaid balance, Contractor shall pay the difference to Owner. Such claims, costs, losses, and damages incurred by Owner will be reviewed by Engineer as to their reasonableness and, when so approved by Engineer, incorporated in a Change Order. When exercising any rights or remedies under this paragraph, Owner shall not be required to obtain the lowest price for the Work performed.
- F. Where Contractor's services have been so terminated by Owner, the termination will not affect any rights or remedies of Owner against Contractor then existing or which may thereafter accrue, or any rights or remedies of Owner against Contractor or any surety under any payment bond or performance bond. Any retention or payment of money due Contractor by Owner will not release Contractor from liability.
- G. If and to the extent that Contractor has provided a performance bond under the provisions of Paragraph 6.01.A, the provisions of that bond shall govern over any inconsistent provisions of Paragraphs 16.02.B and 16.02.D.

16.03 *Owner May Terminate For Convenience*

- A. Upon seven days written notice to Contractor and Engineer, Owner may, without cause and without prejudice to any other right or remedy of Owner, terminate the Contract. In such case, Contractor shall be paid for (without duplication of any items):
  - 60. completed and acceptable Work executed in accordance with the Contract Documents prior to the effective date of termination, including fair and reasonable sums for overhead and profit on such Work;

61. expenses sustained prior to the effective date of termination in performing services and furnishing labor, materials, or equipment as required by the Contract Documents in connection with uncompleted Work, plus fair and reasonable sums for overhead and profit on such expenses; and
  62. other reasonable expenses directly attributable to termination, including costs incurred to prepare a termination for convenience cost proposal.
- B. Contractor shall not be paid on account of loss of anticipated overhead, profits, or revenue, or other economic loss arising out of or resulting from such termination.

16.04 *Contractor May Stop Work or Terminate*

- A. If, through no act or fault of Contractor, (1) the Work is suspended for more than 90 consecutive days by Owner or under an order of court or other public authority, or (2) Engineer fails to act on any Application for Payment within 30 days after it is submitted, or (3) Owner fails for 30 days to pay Contractor any sum finally determined to be due, then Contractor may, upon seven days written notice to Owner and Engineer, and provided Owner or Engineer do not remedy such suspension or failure within that time, terminate the contract and recover from Owner payment on the same terms as provided in Paragraph 16.03.
- B. In lieu of terminating the Contract and without prejudice to any other right or remedy, if Engineer has failed to act on an Application for Payment within 30 days after it is submitted, or Owner has failed for 30 days to pay Contractor any sum finally determined to be due, Contractor may, seven days after written notice to Owner and Engineer, stop the Work until payment is made of all such amounts due Contractor, including interest thereon. The provisions of this paragraph are not intended to preclude Contractor from submitting a Change Proposal for an adjustment in Contract Price or Contract Times or otherwise for expenses or damage directly attributable to Contractor's stopping the Work as permitted by this paragraph.

**ARTICLE 17 – FINAL RESOLUTION OF DISPUTES**

17.01 *Methods and Procedures*

- A. *Disputes Subject to Final Resolution:* The following disputed matters are subject to final resolution under the provisions of this Article:
63. A timely appeal of an approval in part and denial in part of a Claim, or of a denial in full; and
  64. Disputes between Owner and Contractor concerning the Work or obligations under the Contract Documents, and arising after final payment has been made.
- B. *Final Resolution of Disputes:* For any dispute subject to resolution under this Article, Owner or Contractor may:
65. elect in writing to invoke the dispute resolution process provided for in the Supplementary Conditions; or
  66. agree with the other party to submit the dispute to another dispute resolution process; or
  67. if no dispute resolution process is provided for in the Supplementary Conditions or mutually agreed to, give written notice to the other party of the intent to submit the dispute to a court of competent jurisdiction.

## **ARTICLE 18 – MISCELLANEOUS**

### **18.01 *Giving Notice***

- A. Whenever any provision of the Contract Documents requires the giving of written notice, it will be deemed to have been validly given if:
  - 68. delivered in person, by a commercial courier service or otherwise, to the individual or to a member of the firm or to an officer of the corporation for which it is intended; or
  - 69. delivered at or sent by registered or certified mail, postage prepaid, to the last business address known to the sender of the notice.

### **18.02 *Computation of Times***

- A. When any period of time is referred to in the Contract by days, it will be computed to exclude the first and include the last day of such period. If the last day of any such period falls on a Saturday or Sunday or on a day made a legal holiday by the law of the applicable jurisdiction, such day will be omitted from the computation.

### **18.03 *Cumulative Remedies***

- A. The duties and obligations imposed by these General Conditions and the rights and remedies available hereunder to the parties hereto are in addition to, and are not to be construed in any way as a limitation of, any rights and remedies available to any or all of them which are otherwise imposed or available by Laws or Regulations, by special warranty or guarantee, or by other provisions of the Contract. The provisions of this paragraph will be as effective as if repeated specifically in the Contract Documents in connection with each particular duty, obligation, right, and remedy to which they apply.

### **18.04 *Limitation of Damages***

- A. With respect to any and all Change Proposals, Claims, disputes subject to final resolution, and other matters at issue, neither Owner nor Engineer, nor any of their officers, directors, members, partners, employees, agents, consultants, or subcontractors, shall be liable to Contractor for any claims, costs, losses, or damages sustained by Contractor on or in connection with any other project or anticipated project.

### **18.05 *No Waiver***

- A. A party's non-enforcement of any provision shall not constitute a waiver of that provision, nor shall it affect the enforceability of that provision or of the remainder of this Contract.

### **18.06 *Survival of Obligations***

- A. All representations, indemnifications, warranties, and guarantees made in, required by, or given in accordance with the Contract, as well as all continuing obligations indicated in the Contract, will survive final payment, completion, and acceptance of the Work or termination or completion of the Contract or termination of the services of Contractor.

### **18.07 *Controlling Law***

- A. This Contract is to be governed by the law of the state in which the Project is located.

### **18.08 *Headings***

- A. Article and paragraph headings are inserted for convenience only and do not constitute parts of these General Conditions.

## SECTION C-800 SUPPLEMENTARY CONDITIONS

### ARTICLE 2 – PRELIMINARY MATTERS

#### SC -2.01 Copies of Documents

**SC-2.02** Delete Paragraph 2.02.A in its entirety and insert the following new paragraph in its place:

**A.** Owner shall furnish to Contractor four copies of conformed Contract Documents incorporating and integrating all Addenda and any amendments negotiated prior to the Effective Date of the Contract (including one fully executed counterpart of the Agreement), and one copy in electronic portable document format (PDF). Additional printed copies of the conformed Contract Documents will be furnished upon request at the cost of reproduction.

### ARTICLE 6 – BONDS AND INSURANCE

#### SC - 6.03 Add the following new paragraph immediately after Paragraph 6.03.J:

**K.** The limits of liability for the insurance required by Paragraph 6.03 of the General Conditions shall provide coverage for not less than the following amounts or greater where required by Laws and Regulations:

**1.** Workers' Compensation, and related coverages under Paragraphs 6.03.A.1 and A.2 of the General Conditions:

State:	Statutory
Federal, if applicable (e.g., Longshoreman's):	Statutory

Employer's Liability: \$ 1,000,000

**2.** Contractor's Commercial General Liability under Paragraphs 6.03.B and 6.03.C of the General Conditions:

General Aggregate \$ 2,000,000

**Products - Completed Operations Aggregate**      \$ **2,000,000**

---

**Personal and Advertising Injury**      \$ **1,000,000**

---

**Each Occurrence (Bodily Injury and Property Damage)**      \$ **1,000,000**

---

**3. Automobile Liability under Paragraph 6.03.D. of the General Conditions:**

**Bodily Injury:**

**Each person**      \$ **1,000,000**

---

**Each accident**      \$ **1,000,000**

---

**Property Damage:**

**Each accident**      \$ **500,000**

---

*[or]*

**Combined Single Limit of**      \$ **2,000,000**

---

**4. Excess or Umbrella Liability:**

**Per Occurrence**      \$ **1,000,000**

---

**General Aggregate**      \$ **1,000,000**

---

SC-6.05 *Property Insurance*

SC-6.05 Add the following to the list of requirements in Paragraph 6.05.A, as a numbered item:

13. be subject to a deductible amount of no more than \$1,000 for direct physical loss in any one occurrence.

**ARTICLE 8 – OTHER WORK AT THE SITE**

SC-8.02 *Coordination*

SC-8.02 Delete Paragraph 8.02.A in its entirety and replace with the following:

A. Owner intends to contract with others for the performance of other work at or adjacent to the Site.

1. The Owner shall have authority and responsibility for coordination of the various contractors and work forces at the Site;
2. The following specific matters are to be covered by such authority and responsibility:

--The Owner to coordinate activities with contractors.

**ARTICLE 9 – OWNER’S RESPONSIBILITIES**

SC-9.13 *Add the following new paragraph immediately after Paragraph 9.12 of the General Conditions:*

SC-9.13 Owner will furnish an “Owner’s Site Representative” to represent Owner at the Site and assist Owner in observing the progress and quality of the Work. The Owner’s Site Representative is not Engineer’s consultant, agent, or employee. Owner’s Site Representative will be Mark Wise.

**ARTICLE 10 – ENGINEER’S STATUS DURING CONSTRUCTION**

SC-10.03 *Project Representative*

SC-10.03 Add the following new paragraphs immediately after Paragraph 10.03.A:

B. The Resident Project Representative (RPR) will be Engineer's representative at the Site, will act as directed by and under the supervision of Engineer, and will confer with Engineer regarding RPR's actions.

1. General: RPR's dealings in matters pertaining to the Work in general shall be with Engineer and Contractor. RPR's dealings with Subcontractors shall only be through or with the full knowledge and approval of Contractor. RPR shall generally communicate with Owner only with the knowledge of and under the direction of Engineer.

2. **Schedules:** Review the progress schedule, schedule of Shop Drawing and Sample submittals, and Schedule of Values prepared by Contractor and consult with Engineer concerning acceptability.
3. **Conferences and Meetings:** Attend meetings with Contractor, such as preconstruction conferences, progress meetings, job conferences, and other Project-related meetings, and prepare and circulate copies of minutes thereof.
4. **Liaison:**
  - a. **Serve as Engineer's liaison with Contractor.** Working principally through Contractor's authorized representative or designee, assist in providing information regarding the provisions and intent of the Contract Documents.
  - b. **Assist Engineer in serving as Owner's liaison with Contractor** when Contractor's operations affect Owner's on-Site operations.
  - c. **Assist in obtaining from Owner additional details or information,** when required for proper execution of the Work.
5. **Interpretation of Contract Documents:** Report to Engineer when clarifications and interpretations of the Contract Documents are needed and transmit to Contractor clarifications and interpretations as issued by Engineer.
6. **Shop Drawings and Samples:**
  - a. **Record date of receipt of Samples and Contractor-approved Shop Drawings.**
  - b. **Receive Samples which are furnished at the Site by Contractor,** and notify Engineer of availability of Samples for examination.
  - c. **Advise Engineer and Contractor of the commencement of any portion of the Work requiring a Shop Drawing or Sample submittal for which RPR believes that the submittal has not been approved by Engineer.**
7. **Modifications:** Consider and evaluate Contractor's suggestions for modifications in Drawings or Specifications and report such suggestions, together with RPR's recommendations, if any, to Engineer. Transmit to Contractor in writing decisions as issued by Engineer.
8. **Review of Work and Rejection of Defective Work:**
  - a. **Conduct on-Site observations of Contractor's work in progress to assist Engineer in determining if the Work is in general proceeding in accordance with the Contract Documents.**
  - b. **Report to Engineer whenever RPR believes that any part of Contractor's work in progress is defective, will not produce a completed Project that conforms generally to the Contract Documents, or will imperil the integrity of the design concept of the completed Project as a**



functioning whole as indicated in the Contract Documents, or has been damaged, or does not meet the requirements of any inspection, test or approval required to be made; and advise Engineer of that part of work in progress that RPR believes should be corrected or rejected or should be uncovered for observation, or requires special testing, inspection or approval.

**9. Inspections, Tests, and System Start-ups:**

a. Verify that tests, equipment, and systems start-ups and operating and maintenance training are conducted in the presence of appropriate Owner's personnel, and that Contractor maintains adequate records thereof.

b. Observe, record, and report to Engineer appropriate details relative to the test procedures and systems start-ups.

**10. Records:**

a. Prepare a daily report or keep a diary or log book, recording Contractor's hours on the Site, Subcontractors present at the Site, weather conditions, data relative to questions of Change Orders, Field Orders, Work Change Directives, or changed conditions, Site visitors, deliveries of equipment or materials, daily activities, decisions, observations in general, and specific observations in more detail as in the case of observing test procedures; and send copies to Engineer.

b. Record names, addresses, fax numbers, e-mail addresses, web site locations, and telephone numbers of all Contractors, Subcontractors, and major Suppliers of materials and equipment.

c. Maintain records for use in preparing Project documentation.

**11. Reports:**

a. Furnish to Engineer periodic reports as required of progress of the Work and of Contractor's compliance with the Progress Schedule and schedule of Shop Drawing and Sample submittals.

b. Draft and recommend to Engineer proposed Change Orders, Work Change Directives, and Field Orders. Obtain backup material from Contractor.

c. Immediately notify Engineer of the occurrence of any Site accidents, emergencies, acts of God endangering the Work, force majeure or delay events, damage to property by fire or other causes, or the discovery of any Constituent of Concern or Hazardous Environmental Condition.

**12. Payment Requests: Review applications for payment with Contractor for compliance with the established procedure for their submission and forward with recommendations to Engineer, noting particularly the relationship of the payment requested to the Schedule of Values, Work**

completed, and materials and equipment delivered at the Site but not incorporated in the Work.

**13. Certificates, Operation and Maintenance Manuals:** During the course of the Work, verify that materials and equipment certificates, operation and maintenance manuals and other data required by the Contract Documents to be assembled and furnished by Contractor are applicable to the items actually installed and in accordance with the Contract Documents, and have these documents delivered to Engineer for review and forwarding to Owner prior to payment for that part of the Work.

**14. Completion:**

- a. Participate in Engineer's visits to the Site to determine Substantial Completion, assist in the determination of Substantial Completion and the preparation of a punch list of items to be completed or corrected.
- b. Participate in Engineer's final visit to the Site to determine completion of the Work, in the company of Owner and Contractor, and prepare a final punch list of items to be completed and deficiencies to be remedied.
- c. Observe whether all items on the final list have been completed or corrected and make recommendations to Engineer concerning acceptance and issuance of the notice of acceptability of the work.

**C. The RPR shall not:**

1. Authorize any deviation from the Contract Documents or substitution of materials or equipment (including "or-equal" items).
2. Exceed limitations of Engineer's authority as set forth in the Contract Documents.
3. Undertake any of the responsibilities of Contractor, Subcontractors, or Suppliers.
4. Advise on, issue directions relative to, or assume control over any aspect of the means, methods, techniques, sequences or procedures of Contractor's work.
5. Advise on, issue directions regarding, or assume control over security or safety practices, precautions, and programs in connection with the activities or operations of Owner or Contractor.
6. Participate in specialized field or laboratory tests or inspections conducted off-site by others except as specifically authorized by Engineer.
7. Accept Shop Drawing or Sample submittals from anyone other than Contractor.
8. Authorize Owner to occupy the Project in whole or in part.

## **ARTICLE 17 – FINAL RESOLUTION OF DISPUTES**

The arbitration option is as follows:

**SC-17.02 Add the following new paragraph immediately after Paragraph 17.01.**

### **SC-17.02 Arbitration**

**A. All matters subject to final resolution under this Article will be decided by arbitration in accordance with the rules of State of Florida, subject to the conditions and limitations of this paragraph. This agreement to arbitrate and any other agreement or consent to arbitrate entered into will be specifically enforceable under the prevailing law of any court having jurisdiction.**

**B. The demand for arbitration will be filed in writing with the other party to the Contract and with the selected arbitrator or arbitration provider, and a copy will be sent to Engineer for information. The demand for arbitration will be made within the specific time required in this Article, or if no specified time is applicable within a reasonable time after the matter in question has arisen, and in no event shall any such demand be made after the date when institution of legal or equitable proceedings based on such matter in question would be barred by the applicable statute of limitations. The demand for arbitration should include specific reference to Paragraph SC-17.02.D below.**

**C. No arbitration arising out of or relating to the Contract shall include by consolidation, joinder, or in any other manner any other individual or entity (including Engineer, and Engineer's consultants and the officers, directors, partners, agents, employees or consultants of any of them) who is not a party to this Contract unless:**

- 1. the inclusion of such other individual or entity is necessary if complete relief is to be afforded among those who are already parties to the arbitration; and**
- 2. such other individual or entity is substantially involved in a question of law or fact which is common to those who are already parties to the arbitration and which will arise in such proceedings.**

**D. The award rendered by the arbitrator(s) shall be consistent with the agreement of the parties, in writing, and include a concise breakdown of the award, and a written explanation of the award specifically citing the Contract provisions deemed applicable and relied on in making the award.**

**E. The award will be final. Judgment may be entered upon it in any court having jurisdiction thereof, and it will not be subject to modification or appeal, subject to provisions of the Laws and Regulations relating to vacating or modifying an arbitral award.**

**F. The fees and expenses of the arbitrators and any arbitration service shall be shared equally by Owner and Contractor.**



**SECTION C-941  
CHANGE ORDER**

Change Order No. \_\_\_\_\_

Date of Issuance:  
Owner:  
Contractor:  
Engineer:  
Project:

Effective Date:  
Owner's Contract No.:  
Contractor's Project No.:  
Engineer's Project No.:  
Contract Name:

The Contract is modified as follows upon execution of this Change Order:

Description:

Attachments: *[List documents supporting change]*

CHANGE IN CONTRACT PRICE	CHANGE IN CONTRACT TIMES <i>[note changes in Milestones if applicable]</i>
Original Contract Price: \$ _____	Original Contract Times: Substantial Completion: _____ Ready for Final Payment: _____ days or dates
[Increase] [Decrease] from previously approved Change Orders No. ___ to No. ___: \$ _____	[Increase] [Decrease] from previously approved Change Orders No. ___ to No. ___: Substantial Completion: _____ Ready for Final Payment: _____ days
Contract Price prior to this Change Order: \$ _____	Contract Times prior to this Change Order: Substantial Completion: _____ Ready for Final Payment: _____ days or dates
[Increase] [Decrease] of this Change Order: \$ _____	[Increase] [Decrease] of this Change Order: Substantial Completion: _____ Ready for Final Payment: _____ days or dates
Contract Price incorporating this Change Order: \$ _____	Contract Times with all approved Change Orders: Substantial Completion: _____ Ready for Final Payment: _____ days or dates

RECOMMENDED:		ACCEPTED:		ACCEPTED:	
By: _____	By: _____	By: _____	By: _____	By: _____	By: _____
Engineer (if required)	Owner (Authorized Signature)	Contractor (Authorized Signature)			
Title: _____	Title: _____	Title: _____			
Date: _____	Date: _____	Date: _____			

Approved by Funding Agency (if applicable)

By: \_\_\_\_\_ Date: \_\_\_\_\_  
Title: \_\_\_\_\_



---

**TECHNICAL  
SPECIFICATIONS**

---





**SECTION 01 11 00  
SUMMARY OF WORK**

**PART 1 GENERAL**

1.01 WORK COVERED BY CONTRACT DOCUMENTS

- A. The completed Work will provide Owner with a new water distribution main and includes the installation of a 20-inch HDPE waterline across Santa Rosa Sound via horizontal directional drilling. The Contractor is only responsible for completing the work between the entry and exit bore pits. Work outside of these areas between the bore pits and the connections to the existing water system is outside the Contractor's scope and will be performed by the Owner.

**PART 2 PRODUCTS (NOT USED)**

**PART 3 EXECUTION (NOT USED)**

**END OF SECTION**



**SECTION 01 29 00**  
**PAYMENT PROCEDURES**

**PART 1      GENERAL**

1.01      SUBMITTALS

- A.    Informational Submittals:
  - 1.    Schedule of Values: Submit on Contractor's standard form.
  - 2.    Application for Payment.
  - 3.    Final Application for Payment.

1.02      CASH ALLOWANCES

- A.    Cash allowances will be administered in accordance with Paragraph 13.02 of General Conditions.
- B.    Submit, with application for payment, invoice showing date of purchase, from whom the purchase was made, the date the construction easement is contracted, and the price including applicable taxes.

1.03      SCHEDULE OF VALUES

- A.    Prepare a separate Schedule of Values for each schedule of the Work under the Agreement.
- B.    Upon request of Engineer, provide documentation to support the accuracy of the Schedule of Values.
- C.    Unit Price Work: Reflect unit price quantity and price breakdown from conformed Bid Form.
- D.    Lump Sum Work:
  - 1.    Reflect specified cash allowance as applicable.
  - 2.    List bonds and insurance premiums, mobilization, demobilization, preliminary and detailed progress schedule preparation, equipment testing, facility startup, and contract closeout separately.
    - a.    Mobilization includes, at minimum, items identified in Section 01 50 00, Temporary Facilities and Controls.
    - b.    Include item(s) for monthly progress schedule update.
- E.    An unbalanced or front-end loaded schedule will not be acceptable.
- F.    Summation of the complete Schedule of Values representing all the Work shall equal the Contract Price.

1.04 APPLICATION FOR PAYMENT

- A. Transmittal Summary Form: Attach one Summary Form with each detailed Application for Payment for each schedule and include Request for Payment of Materials and Equipment on Hand as applicable. Execute certification by authorized officer of Contractor.
- B. Use detailed Application for Payment Form suitable to Engineer.
- C. Include separate line item for each Change Order and Work Change Directive executed prior to date of submission. Provide further breakdown of such as requested by Engineer.
- D. Preparation:
  - 1. Round values to nearest dollar.
  - 2. Submit Application for Payment, including a Transmittal Summary Form and detailed Application for Payment Form(s) for each schedule as applicable, a listing of materials on hand for each schedule as applicable, and such supporting data as may be requested by Engineer.

1.05 PAYMENT

- A. Payment for all Lump Sum Work shown or specified in Contract Documents is included in the Contract Price. Payment for all work, excluding mobilization, will be made to contractor following complete installation and successful pressure testing of new water line. No partial payments based upon percentage of completion or stored materials will be awarded.
- B. Payment for Lump Sum Work covers all Work specified or shown within the limits shown on the Drawings.

Item	Description
Mobilization	Includes all associated costs for Contractor to facilitate the beginning of the Project and obtain all required equipment at Project Site. Extended bid unit cost of mobilization shall not exceed 5 percent of the Total Extended Bid Unit Price.
Erosion Control Measures	Includes all Work required for contractor to develop BMP plan, install silt fence and temporary fencing.

Item	Description
20-inch Diameter HDPE Directional Drill (Including Drill Pits and Pipe Thrust Block)	Includes all pipe and appurtenances along with all labor and equipment costs necessary to install the 20" HDPE watermain and thrust blocks. Costs for fused pipe staging, traffic control and site restoration shall also be included in this item.

1.06 NONPAYMENT FOR REJECTED OR UNUSED PRODUCTS

A. Payment will not be made for following:

1. Loading, hauling, and disposing of rejected material.
2. Quantities of material wasted or disposed of in manner not called for under Contract Documents.
3. Rejected loads of material, including material rejected after it has been placed by reason of failure of Contractor to conform to provisions of Contract Documents.
4. Material not unloaded from transporting vehicle.
5. Defective Work not accepted by Owner.
6. Material remaining on hand after completion of Work.

1.07 PARTIAL PAYMENT FOR STORED MATERIALS AND EQUIPMENT

- A. Partial Payment: No partial payments will be made for materials and equipment delivered or stored.

**PART 2 PRODUCTS (NOT USED)**

**PART 3 EXECUTION (NOT USED)**

**END OF SECTION**



**SECTION 01 31 13**  
**PROJECT COORDINATION**

**PART 1 GENERAL**

1.01 SUBMITTALS

A. Informational:

1. Photographs:
  - a. Digital Images: Submit one copy of DVD disc containing images within 5 days of being taken Each image is to have a minimum file size of 1.4 Mb (1,400 Kb) so viewed resolution is high quality. The production of larger file sizes with higher resolution is encouraged.
2. Video Recordings: Submit one copy including updated copy of project video log, within 5 days of being taken.

1.02 RELATED WORK AT SITE

A. General:

1. Other work that is either directly or indirectly related to scheduled performance of the Work under these Contract Documents, listed henceforth, is anticipated to be performed at Site by others.
2. Coordinate the Work of these Contract Documents with work of others as specified in General Conditions.
3. Include sequencing constraints specified herein as a part of Progress Schedule.

B. Owner

1. Agency and Contact Person: OCWS – Jeremy Williams, telephone number: (850) 609-5098.
2. Work to be performed by OCWS:
  - a. Demolition of existing structure near entry pit.
  - b. Direct-buried piping installation starting at the HDPE to DI MJ adapter on each end of the HDD.
  - c. Pressure testing of OCWS installed pipe.
  - d. Bac-T testing.
  - e. Water line connections to existing system.
3. Work to be performed by Contractor:
  - a. 20-inch HDPE pipe installation via HDD.
  - b. Installation of transition fittings and caps on pipe ends.
  - c. Pressure testing of Contractor installed pipe.
  - d. Erosion and sediment control.
  - e. Traffic control for pipe fusing staging alignment.

1.03 UTILITY NOTIFICATION AND COORDINATION

- A. Coordinate the Work with various utilities within Project limits. Notify applicable utilities prior to commencing Work, if damage occurs, or if conflicts or emergencies arise during the Work.
  - 1. Electricity Company: Gulf Power
    - a. Contact Person: Tom Dorsey.
    - b. Telephone: (850) 244-4270.
  - 2. Telephone Company:
  - 3. Gas Department: Okaloosa Gas:
    - a. Telephone: (850) 729-4700.
  - 4. Public Works Department: City of Fort Walton Beach:
    - a. Contact Person: Daniel Payne.
    - b. Telephone: (850) 833-9615.

1.04 ADJACENT FACILITIES AND PROPERTIES

- A. Examination:
  - 1. After Effective Date of the Agreement and before Work at Site is started, Contractor, Engineer, and affected property owners and utility owners shall make a thorough examination of pre-existing conditions including existing buildings, structures, and other improvements in vicinity of Work, as applicable, which could be damaged by construction operations.
  - 2. Periodic reexamination shall be jointly performed to include, but not limited to, cracks in structures, settlement, leakage, and similar conditions.
- B. Documentation:
  - 1. Record and submit documentation of observations made on examination inspections in accordance with Article Construction Photographs.
  - 2. Such documentation shall be used as indisputable evidence in ascertaining whether and to what extent damage occurred as a result of Contractor's operations, and is for the protection of adjacent property owners, Contractor, and Owner.

1.05 CONSTRUCTION PHOTOGRAPHS

- A. General:
  - 1. Photographically document all phases of the Project including preconstruction, construction progress, and post-construction.
  - 2. Engineer shall have right to select subject matter and vantage point from which photographs are to be taken.



- B. Preconstruction and Post-Construction:
  - 1. After Effective Date of the Agreement and before Work at Site is started, and again upon issuance of Substantial Completion, take a minimum of 48 photographs of Site and property adjacent to perimeter of Site.
  - 2. Particular emphasis shall be directed to structures both inside and outside the Site.
- C. Documentation:
  - 1. Digital Images:
    - a. Electronic image shall have date taken embedded into image.
    - b. Label file folders or database records with Project and Owner's name, and month and year images were produced.

#### 1.06 AUDIO-VIDEO RECORDINGS

- A. Prior to beginning the Work on Site or of a particular area of the Work, and again within 10 days following date of Substantial Completion, videograph Site and property adjacent to Site.
- B. In the case of preconstruction recording, no work shall begin in the area prior to Engineer's review and approval of content and quality of video for that area.
- C. Particular emphasis shall be directed to physical condition of existing vegetation, structures, and pavements within project site and areas adjacent to and within the right-of-way or easement, and on Contractor storage and staging areas including the pipe laydown area.
- D. Engineer shall have right to select subject matter and vantage point from which videos are to be taken.
- E. Video Format and Quality:
  - 1. DVD format, with sound.
  - 2. Video:
    - a. Produce bright, sharp, and clear images with accurate colors, free of distortion and other forms of picture imperfections.
    - b. Electronically, and accurately display the month, day, year, and time of day of the recording.
  - 3. Audio:
    - a. Audio documentation shall be done clearly, precisely, and at a moderate pace.

- b. Indicate date, project name, and a brief description of the location of recording, including:
  - 1) Facility name.
  - 2) Street names or easements.
  - 3) Addresses of private property.
  - 4) Direction of coverage, including engineering stationing, if applicable.

F. Documentation:

1. DVD Label:
  - a. DVD number (numbered sequentially, beginning with 001).
  - b. Project name.
  - c. Name of street(s) or easement(s) included.
  - d. Date and time of coverage.

1.07 REFERENCE POINTS AND SURVEYS

A. Owner's Responsibilities:

1. Establish bench marks convenient to Work and at least every 500 feet on pipelines and roads.
2. Establish horizontal reference points or coordinate system with bench marks and reference points for Contractor's use as necessary to lay out Work.

B. Location and elevation of bench marks are shown on Drawings.

C. Contractor's Responsibilities:

1. Provide additional survey and layout required to layout the Work.
2. Notify Engineer at least 3 working days in advance of time when grade and line to be provided by Owner will be needed.
3. Check and establish exact location of existing facilities prior to construction of new facilities and any connections thereto.
4. In event of discrepancy in data or staking provided by Owner, request clarification before proceeding with Work.
5. Maintain complete accurate log of survey work as it progresses as a Record Document.
6. On request of Engineer, submit documentation.
7. Provide competent employee(s), tools, stakes, and other equipment and materials as Engineer may require to:
  - a. Establish control points, lines, and easement boundaries.
  - b. Check layout, survey, and measurement work performed by others.
  - c. Measure quantities for payment purposes.

**PART 2 PRODUCTS (NOT USED)****PART 3 EXECUTION**

## 3.01 CUTTING, FITTING, AND PATCHING

- A. Cut, fit, adjust, or patch Work and work of others, including excavation and backfill as required, to make Work complete.
- B. Obtain prior written authorization of Engineer before commencing Work to cut or otherwise alter:
  - 1. Structural or reinforcing steel, structural column or beam, elevated slab, trusses, or other structural member.
  - 2. Weather-resistant or moisture-resistant elements.
  - 3. Efficiency, maintenance, or safety of element.
  - 4. Work of others.
- C. Refinish surfaces to provide an even finish.
  - 1. Refinish continuous surfaces to nearest intersection.
  - 2. Refinish entire assemblies.
  - 3. Finish restored surfaces to such planes, shapes, and textures that no transition between existing work and the Work is evident in finished surfaces.
- D. Restore existing work, Underground Facilities, and surfaces that are to remain in completed Work including concrete-embedded piping, conduit, and other utilities as specified and as shown on Drawings.
- E. Make restorations with new materials and appropriate methods as specified for new Work of similar nature; if not specified, use recommended practice of manufacturer or appropriate trade association.
- F. Fit Work airtight to pipes, sleeves, ducts, conduit, and other penetrations through surfaces and fill voids.
- G. Remove specimens of installed Work for testing when requested by Engineer.

**END OF SECTION**



**SECTION 01 33 00**  
**SUBMITTAL PROCEDURES**

**PART 1 GENERAL**

1.01 DEFINITIONS

- A. Action Submittal: Written and graphic information submitted by Contractor that requires Engineer's approval.
- B. Informational Submittal: Information submitted by Contractor that requires Engineer's review and determination that submitted information is in accordance with the Conditions of the Contract.

1.02 PROCEDURES

- A. Direct submittals to Engineer at the following, unless specified otherwise.
  - 1. CH2M HILL  
Attn: Kevin Waddell
  - 2. E-mail: [kevin.waddell@ch2m.com](mailto:kevin.waddell@ch2m.com).
- B. Electronic Submittals: Submittals may be made in electronic format.
  - 1. Each submittal shall be an electronic file in Adobe Acrobat Portable Document Format (PDF). Use the latest version available at time of execution of the Agreement.
  - 2. Electronic files that contain more than 10 pages in PDF format shall contain internal bookmarking from an index page to major sections of the document.
  - 3. PDF files shall be set to open "Bookmarks and Page" view.
  - 4. Add general information to each PDF file, including title, subject, author, and keywords.
  - 5. PDF files shall be set up to print legibly at 8.5-inch by 11-inch, 11-inch by 17-inch, or 22-inch by 34-inch. No other paper sizes will be accepted.
  - 6. Submit new electronic files for each resubmittal.
  - 7. Include a copy of the Transmittal of Contractor's Submittal form, located at end of section, with each electronic file.
  - 8. Provide Engineer with authorization to reproduce and distribute each file as many times as necessary for Project documentation.
  - 9. Detailed procedures for handling electronic submittals will be discussed at the preconstruction conference.

C. Transmittal of Submittal:

1. Contractor shall:
  - a. Review each submittal and check for compliance with Contract Documents.
  - b. Stamp each submittal with uniform approval stamp before submitting to Engineer.
    - 1) Stamp to include Project name, submittal number, Specification number, Contractor's reviewer name, date of Contractor's approval, and statement certifying submittal has been reviewed, checked, and approved for compliance with Contract Documents.
    - 2) Engineer will not review submittals that do not bear Contractor's approval stamp and will return them without action.
2. Complete, sign, and transmit with each submittal package, one Transmittal of Contractor's Submittal form attached at end of this section.
3. Identify each submittal with the following:
  - a. Numbering and Tracking System:
    - 1) Sequentially number each submittal.
    - 2) Resubmission of submittal shall have original number with sequential alphabetic suffix.
  - b. Specification section and paragraph to which submittal applies.
  - c. Project title and Engineer's project number.
  - d. Date of transmittal.
  - e. Names of Contractor, Subcontractor or Supplier, and manufacturer as appropriate.
4. Identify and describe each deviation or variation from Contract Documents.

D. Format:

1. Do not base Shop Drawings on reproductions of Contract Documents.
2. Package submittal information by individual specification section. Do not combine different specification sections together in submittal package, unless otherwise directed in specification.
3. Present in a clear and thorough manner and in sufficient detail to show kind, size, arrangement, and function of components, materials, and devices, and compliance with Contract Documents.
4. Index with labeled tab dividers in orderly manner.

E. Timeliness: Schedule and submit in accordance Schedule of Submittals, and requirements of individual specification sections.

## F. Processing Time:

1. Time for review shall commence on Engineer's receipt of submittal.
2. Engineer will act upon Contractor's submittal and transmit response to Contractor not later than 30 days after receipt, unless otherwise specified.
3. Resubmittals will be subject to same review time.
4. No adjustment of Contract Times or Price will be allowed as a result of delays in progress of Work caused by rejection and subsequent resubmittals.

## G. Resubmittals: Clearly identify each correction or change made.

## H. Incomplete Submittals:

1. Engineer will return entire submittal for Contractor's revision if preliminary review deems it incomplete.
2. When any of the following are missing, submittal will be deemed incomplete:
  - a. Contractor's review stamp; completed and signed.
  - b. Transmittal of Contractor's Submittal; completed and signed.

## I. Submittals not required by Contract Documents:

1. Will not be reviewed and will be returned stamped "Not Subject to Review."
2. Engineer will keep one copy and return submittal to Contractor.

## 1.03 ACTION SUBMITTALS

## A. Prepare and submit Action Submittals required by individual specification sections.

## B. Shop Drawings:

1. Identify and Indicate:
  - a. Applicable Contract Drawing and Detail number, products, units and assemblies, and system or equipment identification or tag numbers.
  - b. Equipment and Component Title: Identical to title shown on Drawings.
  - c. Critical field dimensions and relationships to other critical features of Work. Note dimensions established by field measurement.
  - d. Project-specific information drawn accurately to scale.

2. Manufacturer's standard schematic drawings and diagrams as follows:
  - a. Modify to delete information that is not applicable to the Work.
  - b. Supplement standard information to provide information specifically applicable to the Work.
3. Product Data: Provide as specified in individual specifications.
4. Foreign Manufacturers: When proposed, include names and addresses of at least two companies that maintain technical service representatives close to Project.

C. Samples:

1. Copies: Two, unless otherwise specified in individual specifications.
2. Preparation: Mount, display, or package Samples in manner specified to facilitate review of quality. Attach label on unexposed side that includes the following:
  - a. Manufacturer name.
  - b. Model number.
  - c. Material.
  - d. Sample source.
3. Manufacturer's Color Chart: Units or sections of units showing full range of colors, textures, and patterns available.
4. Full-size Samples:
  - a. Size as indicated in individual specification section.
  - b. Prepared from same materials to be used for the Work.
  - c. Cured and finished in manner specified.
  - d. Physically identical with product proposed for use.

D. Action Submittal Dispositions: Engineer will review, comment, stamp, and distribute as noted:

1. Approved:
  - a. Contractor may incorporate product(s) or implement Work covered by submittal.
  - b. Distribution: Electronic.
2. Approved as Noted:
  - a. Contractor may incorporate product(s) or implement Work covered by submittal, in accordance with Engineer's notations.
  - b. Distribution: Electronic.
3. Partial Approval, Resubmit as Noted:
  - a. Make corrections or obtain missing portions, and resubmit.
  - b. Except for portions indicated, Contractor may begin to incorporate product(s) or implement Work covered by submittal, in accordance with Engineer's notations.
  - c. Distribution: Electronic.



4. Revise and Resubmit:
  - a. Contractor may not incorporate product(s) or implement Work covered by submittal.
  - b. Distribution: Electronic.

#### 1.04 INFORMATIONAL SUBMITTALS

##### A. General:

1. Refer to individual specification sections for specific submittal requirements.
2. Engineer will review each submittal. If submittal meets conditions of the Contract, Engineer will forward copy to appropriate parties. If Engineer determines submittal does not meet conditions of the Contract and is therefore considered unacceptable, Engineer will retain one copy and return remaining copy with review comments to Contractor, and require that submittal be corrected and resubmitted.

##### B. Certificates:

1. General:
  - a. Provide notarized statement that includes signature of entity responsible for preparing certification.
  - b. Signed by officer or other individual authorized to sign documents on behalf of that entity.
2. Welding: In accordance with individual specification sections.
3. Installer: Prepare written statements on manufacturer's letterhead certifying installer complies with requirements as specified in individual specification section.
4. Material Test: Prepared by qualified testing agency, on testing agency's standard form, indicating and interpreting test results of material for compliance with requirements.
5. Certificates of Successful Testing or Inspection: Submit when testing or inspection is required by Laws and Regulations or governing agency or specified in individual specification sections.
6. Manufacturer's Certificate of Compliance: In accordance with Section 01 61 00, Common Product Requirements.
7. Manufacturer's Certificate of Proper Installation: In accordance with Section 01 43 33, Manufacturers' Field Services.

C. Construction Photographs and Video: In accordance with Section 01 31 13, Project Coordination, and as may otherwise be required in Contract Documents.

D. Closeout Submittals: In accordance with Section 01 77 00, Closeout Procedures.

- E. Contractor-design Data (related to temporary construction):
  - 1. Written and graphic information.
  - 2. List of assumptions.
  - 3. List of performance and design criteria.
  - 4. Summary of loads or load diagram, if applicable.
  - 5. Calculations.
  - 6. List of applicable codes and regulations.
  - 7. Name and version of software.
  - 8. Information requested in individual specification section.
  
- F. Manufacturer's Instructions: Written or published information that documents manufacturer's recommendations, guidelines, and procedures in accordance with individual specification section.
  
- G. Operation and Maintenance Data: As required in Section 01 78 23, Operation and Maintenance Data.
  
- H. Payment:
  - 1. Application for Payment: In accordance with Section 01 29 00, Payment Procedures.
  - 2. Schedule of Values: In accordance with Section 01 29 00, Payment Procedures.
  
- I. Quality Control Documentation: As required in Section 01 45 16.13, Contractor Quality Control.
  
- J. Schedules:
  - 1. Schedule of Submittals: Prepare separately or in combination with Progress Schedule as specified in Section 01 32 00, Construction Progress Documentation.
    - a. Show for each, at a minimum, the following:
      - 1) Specification section number.
      - 2) Identification by numbering and tracking system as specified under Paragraph Transmittal of Submittal.
      - 3) Estimated date of submission to Engineer, including reviewing and processing time.
    - b. On a monthly basis, submit updated Schedule of Submittals to Engineer if changes have occurred or resubmittals are required.
  - 2. Progress Schedules: In accordance with Section 01 32 00, Construction Progress Documentation.
  
- K. Special Guarantee: Supplier's written guarantee as required in individual specification sections.

- L. Statement of Qualification: Evidence of qualification, certification, or registration as required in Contract Documents to verify qualifications of professional land surveyor, engineer, materials testing laboratory, specialty Subcontractor, trade, Specialist, consultant, installer, and other professionals.
- M. Submittals Required by Laws, Regulations, and Governing Agencies:
1. Promptly submit promptly notifications, reports, certifications, payrolls, and otherwise as may be required, directly to the applicable federal, state, or local governing agency or their representative.
  2. Transmit to Engineer for Owner's records one copy of correspondence and transmittals (to include enclosures and attachments) between Contractor and governing agency.
- N. Test, Evaluation, and Inspection Reports:
1. General: Shall contain signature of person responsible for test or report.
  2. Factory:
    - a. Identification of product and specification section, type of inspection or test with referenced standard or code.
    - b. Date of test, Project title and number, and name and signature of authorized person.
    - c. Test results.
    - d. If test or inspection deems material or equipment not in compliance with Contract Documents, identify corrective action necessary to bring into compliance.
    - e. Provide interpretation of test results, when requested by Engineer.
    - f. Other items as identified in individual specification sections.
  3. Field:
    - a. As a minimum, include the following:
      - 1) Project title and number.
      - 2) Date and time.
      - 3) Record of temperature and weather conditions.
      - 4) Identification of product and specification section.
      - 5) Type and location of test, Sample, or inspection, including referenced standard or code.
      - 6) Date issued, testing laboratory name, address, and telephone number, and name and signature of laboratory inspector.
      - 7) If test or inspection deems material or equipment not in compliance with Contract Documents, identify corrective action necessary to bring into compliance.
      - 8) Provide interpretation of test results, when requested by Engineer.
      - 9) Other items as identified in individual specification sections.

691267A.GN1

- O. Testing and Startup Data: In accordance with Section 01 91 14, Equipment Testing and Facility Startup.
- P. Training Data: In accordance with Section 01 43 33, Manufacturers' Field Services.

1.05 SUPPLEMENTS

- A. The supplements listed below, following "End of Section", are part of this specification.

- 1. Forms: Transmittal of Contractor's Submittal.

**PART 2 PRODUCTS (NOT USED)**

**PART 3 EXECUTION (NOT USED)**

**END OF SECTION**

 <b>TRANSMITTAL OF CONTRACTOR'S SUBMITTAL</b> (ATTACH TO EACH SUBMITTAL)			
DATE: _____			
<b>TO:</b> _____ _____ _____ _____  <b>FROM:</b> _____ <div style="text-align: center;">Contractor</div> _____ _____ _____	Submittal No.: _____ <input type="checkbox"/> New Submittal <input type="checkbox"/> Resubmittal Project: _____ Project No.: _____ Specification Section No.: _____ <b>(Cover only one section with each transmittal)</b> Schedule Date of Submittal: _____		
<b>SUBMITTAL TYPE:</b>	<input type="checkbox"/> Shop Drawing	<input type="checkbox"/> Sample	<input type="checkbox"/> Informational
	<input type="checkbox"/> Deferred		

**The following items are hereby submitted:**

Number of Copies	Description of Item Submitted (Type, Size, Model Number, Etc.)	Spec. and Para. No.	Drawing or Brochure Number	Contains Variation to Contract	
				No	Yes

Contractor hereby certifies that (i) Contractor has complied with the requirements of Contract Documents in preparation, review, and submission of designated Submittal and (ii) the Submittal is complete and in accordance with the Contract Documents and requirements of laws and regulations and governing agencies.

By: \_\_\_\_\_  
 Contractor (Authorized Signature)



**SECTION 01 42 13**  
**ABBREVIATIONS AND ACRONYMS**

**PART 1      GENERAL**

- 1.01      REFERENCE TO STANDARDS AND SPECIFICATIONS OF TECHNICAL SOCIETIES
- A.      Reference to standards and specifications of technical societies and reporting and resolving discrepancies associated therewith shall be as provided in Article 3 of the General Conditions, and as may otherwise be required herein and in the individual Specification sections.
  - B.      Work specified by reference to published standard or specification of government agency, technical association, trade association, professional society or institute, testing agency, or other organization shall meet requirements or surpass minimum standards of quality for materials and workmanship established by designated standard or specification.
  - C.      Where so specified, products or workmanship shall also meet or exceed additional prescriptive or performance requirements included within Contract Documents to establish a higher or more stringent standard of quality than required by referenced standard.
  - D.      Where two or more standards are specified to establish quality, product and workmanship shall meet or exceed requirements of most stringent.
  - E.      Where both a standard and a brand name are specified for a product in Contract Documents, proprietary product named shall meet or exceed requirements of specified reference standard.
  - F.      Copies of standards and specifications of technical societies:
    - 1.      Copies of applicable referenced standards have not been bound in these Contract Documents.
    - 2.      Where copies of standards are needed by Contractor, obtain a copy or copies directly from publication source and maintain in an orderly manner at the Site as Work Site records, available to Contractor's personnel, Subcontractors, Owner, and Engineer.

## 1.02 ABBREVIATIONS

A. Abbreviations for trade organizations and government agencies: Following is a list of construction industry organizations and government agencies to which references may be made in the Contract Documents, with abbreviations used.

1.	AA	Aluminum Association
2.	AABC	Associated Air Balance Council
3.	AAMA	American Architectural Manufacturers Association
4.	AASHTO	American Association of State Highway and Transportation Officials
5.	ABMA	American Bearing Manufacturers' Association
6.	ACI	American Concrete Institute
7.	AEIC	Association of Edison Illuminating Companies
8.	AGA	American Gas Association
9.	AGMA	American Gear Manufacturers' Association
10.	AI	Asphalt Institute
11.	AISC	American Institute of Steel Construction
12.	AISI	American Iron and Steel Institute
13.	AITC	American Institute of Timber Construction
14.	ALS	American Lumber Standards
15.	AMCA	Air Movement and Control Association
16.	ANSI	American National Standards Institute
17.	APA	APA – The Engineered Wood Association
18.	API	American Petroleum Institute
19.	APWA	American Public Works Association
20.	AHRI	Air-Conditioning, Heating, and Refrigeration Institute
21.	ASA	Acoustical Society of America
22.	ASABE	American Society of Agricultural and Biological Engineers
23.	ASCE	American Society of Civil Engineers
24.	ASHRAE	American Society of Heating, Refrigerating and Air-Conditioning Engineers, Inc.
25.	ASME	American Society of Mechanical Engineers
26.	ASNT	American Society for Nondestructive Testing
27.	ASSE	American Society of Sanitary Engineering
28.	ASTM	ASTM International
29.	AWI	Architectural Woodwork Institute
30.	AWPA	American Wood Preservers' Association
31.	AWPI	American Wood Preservers' Institute
32.	AWS	American Welding Society
33.	AWWA	American Water Works Association



34.	BHMA	Builders Hardware Manufacturers' Association
35.	CBM	Certified Ballast Manufacturer
36.	CDA	Copper Development Association
37.	CGA	Compressed Gas Association
38.	CISPI	Cast Iron Soil Pipe Institute
39.	CMAA	Crane Manufacturers' Association of America
40.	CRSI	Concrete Reinforcing Steel Institute
41.	CS	Commercial Standard
42.	CSA	Canadian Standards Association
43.	CSI	Construction Specifications Institute
44.	DIN	Deutsches Institut für Normung e.V.
45.	DIPRA	Ductile Iron Pipe Research Association
46.	EIA	Electronic Industries Alliance
47.	EJCDC	Engineers Joint Contract Documents' Committee
48.	ETL	Electrical Test Laboratories
49.	FAA	Federal Aviation Administration
50.	FCC	Federal Communications Commission
51.	FDA	Food and Drug Administration
52.	FEMA	Federal Emergency Management Agency
53.	FIPS	Federal Information Processing Standards
54.	FM	FM Global
55.	Fed. Spec.	Federal Specifications (FAA Specifications)
56.	FS	Federal Specifications and Standards (Technical Specifications)
57.	GA	Gypsum Association
58.	GANA	Glass Association of North America
59.	HI	Hydraulic Institute
60.	HMI	Hoist Manufacturers' Institute
61.	IBC	International Building Code
62.	ICBO	International Conference of Building Officials
63.	ICC	International Code Council
64.	ICEA	Insulated Cable Engineers' Association
65.	IFC	International Fire Code
66.	IEEE	Institute of Electrical and Electronics Engineers, Inc.
67.	IESNA	Illuminating Engineering Society of North America
68.	IFI	Industrial Fasteners Institute
69.	IGMA	Insulating Glass Manufacturer's Alliance
70.	IMC	International Mechanical Code
71.	INDA	Association of the Nonwoven Fabrics Industry
72.	IPC	International Plumbing Code
73.	ISA	International Society of Automation
74.	ISO	International Organization for Standardization

75.	ITL	Independent Testing Laboratory
76.	JIC	Joint Industry Conferences of Hydraulic Manufacturers
77.	MIA	Marble Institute of America
78.	MIL	Military Specifications
79.	MMA	Monorail Manufacturers' Association
80.	MSS	Manufacturer's Standardization Society
81.	NAAMM	National Association of Architectural Metal Manufacturers
82.	NACE	NACE International
83.	NBGQA	National Building Granite Quarries Association
84.	NEBB	National Environmental Balancing Bureau
85.	NEC	National Electrical Code
86.	NECA	National Electrical Contractor's Association
87.	NEMA	National Electrical Manufacturers' Association
88.	NESC	National Electrical Safety Code
89.	NETA	InterNational Electrical Testing Association
90.	NFPA	National Fire Protection Association
91.	NHLA	National Hardwood Lumber Association
92.	NICET	National Institute for Certification in Engineering Technologies
93.	NIST	National Institute of Standards and Technology
94.	NRCA	National Roofing Contractors Association
95.	NRTL	Nationally Recognized Testing Laboratories
96.	NSF	NSF International
97.	NSPE	National Society of Professional Engineers
98.	NTMA	National Terrazzo and Mosaic Association
99.	NWWDA	National Wood Window and Door Association
100.	OSHA	Occupational Safety and Health Act (both Federal and State)
101.	PCI	Precast/Prestressed Concrete Institute
102.	PEI	Porcelain Enamel Institute
103.	PPI	Plastic Pipe Institute
104.	PS	Product Standards Section-U.S. Department of Commerce
105.	RMA	Rubber Manufacturers' Association
106.	RUS	Rural Utilities Service
107.	SAE	SAE International
108.	SDI	Steel Deck Institute
109.	SDI	Steel Door Institute
110.	SJI	Steel Joist Institute
111.	SMACNA	Sheet Metal and Air Conditioning Contractors National Association
112.	SPI	Society of the Plastics Industry
113.	SSPC	The Society for Protective Coatings

114. STI/SPFA	Steel Tank Institute/Steel Plate Fabricators Association
115. SWI	Steel Window Institute
116. TEMA	Tubular Exchanger Manufacturers' Association
117. TCA	Tile Council of North America
118. TIA	Telecommunications Industry Association
119. UBC	Uniform Building Code
120. UFC	Uniform Fire Code
121. UL	Underwriters Laboratories Inc.
122. UMC	Uniform Mechanical Code
123. USBR	U.S. Bureau of Reclamation
124. WCLIB	West Coast Lumber Inspection Bureau
125. WI	Wood Institute
126. WWPA	Western Wood Products Association

**PART 2 PRODUCTS (NOT USED)**

**PART 3 EXECUTION (NOT USED)**

**END OF SECTION**



**SECTION 01 50 00**  
**TEMPORARY FACILITIES AND CONTROLS**

**PART 1 GENERAL**

1.01 REFERENCES

- A. The following is a list of standards which may be referenced in this section:
1. American Association of Nurserymen (AAN): American Standards for Nursery Stock.
  2. Federal Emergency Management Agency (FEMA).
  3. National Fire Prevention Association (NFPA): 241, Standard for Safeguarding Construction, Alteration, and Demolition Operations.
  4. Telecommunications Industry Association (TIA); Electronic Industries Alliance (EIA): 568B, Commercial Building Telecommunications Cabling Standard.
  5. U.S. Department of Agriculture (USDA): Urban Hydrology for Small Watersheds.
  6. U.S. Weather Bureau: Rainfall-Frequency Atlas of the U.S. for Durations from 30 Minutes to 24 Hours and Return Periods from 1 to 100 Years.

1.02 SUBMITTALS

- A. Informational Submittals:
1. Copies of permits and approvals for construction as required by Laws and Regulations and governing agencies.
  2. Temporary Construction Submittals:
    - a. Staging area location plan.
    - b. Traffic and Pedestrian Control and Routing Plans: As specified herein, and proposed revisions thereto.

1.03 MOBILIZATION

- A. Mobilization includes, but is not limited to, these principal items:
1. Obtaining required permits.
  2. Moving Contractor's field office and equipment required for first month operations onto Site.
  3. Installing temporary construction power, wiring, and lighting facilities.
  4. Providing onsite Internet service.
  5. Providing onsite sanitary facilities and potable water facilities as specified and as required by Laws and Regulations, and governing agencies.

6. Arranging for and erection of Contractor's work and storage yard.
7. Posting OSHA required notices and establishing safety programs and procedures.
8. Having Contractor's superintendent at Site full time.

- B. Use area designated for Contractor's temporary facilities as shown on Drawings.

1.04 PROTECTION OF WORK AND PROPERTY

- A. Comply with Owner's safety rules while on Owner's property.
- B. Keep Owner informed of serious onsite accidents and related claims.

1.05 VEHICULAR TRAFFIC

- A. Traffic Control Plan: Adhere to traffic control plan submitted by Contractor and reviewed and accepted by Engineer. Changes to this plan shall be made only by written approval of appropriate public authority. Secure approvals for necessary changes so as not to delay progress of the Work.
- B. Traffic Routing Plan: Show sequences of construction affecting use of roadways, time required for each phase of the Work, provisions for decking over excavations and phasing of operations to provide necessary access, and plans for signing, barricading, and striping to provide passages for pedestrians and vehicles.

**PART 2 PRODUCTS**

2.01 PROJECT SIGN

- A. Provide and maintain one, 8-foot-wide by 4-foot high sign constructed of 3/4-inch exterior high density overlaid plywood. Sign shall bear name of Project, Owner, Contractor, Engineer, and other participating agencies. Lettering shall be blue applied on white background by an experienced sign painter. Include Owner's logo in full color. Provide exterior type enamel paint. Information to be included and logo graphic will be provided by Engineer.

**PART 3 EXECUTION**

3.01 TEMPORARY UTILITIES

- A. Power: No electric power is available at Site. Make arrangements to obtain and pay for electrical power used.

- B. Lighting: Provide temporary lighting to meet applicable safety requirements to allow erection, application, or installation of materials and equipment, and observation or inspection of the Work.
- C. Water:
  - 1. Hydrant Water:
    - a. Is available from nearby hydrants.
    - b. For any construction water utilized via a hydrant meter, the contractor shall setup an account with OCWS' Customer Service office and provide contract information.
    - c. The account shall be setup in the contractor's name with a deposit and service fee paid by the contractor. The deposit will be refunded when the account terminates if the meter has not been damaged or lost.
    - d. OCWS will be responsible for setting the hydrant, along with the monthly reading. If the hydrant meter needs to be relocated, contractor to coordinate this with OCWS Maintenance.
    - e. Water usage will not be charged to the contractor, provided that the above conditions are met.
- D. Sanitary and Personnel Facilities: Provide and maintain facilities for Contractor's employees, Subcontractors, and other onsite employers' employees. Service, clean, and maintain facilities and enclosures.
- E. Fire Protection: Furnish and maintain on Site adequate firefighting equipment capable of extinguishing incipient fires. Comply with applicable parts of NFPA 241.

### 3.02 PROTECTION OF WORK AND PROPERTY

- A. General:
  - 1. Perform Work within right-of-way and easements in a systematic manner that minimizes inconvenience to property owners and the public.
  - 2. No residence or business shall be cut off from vehicular traffic, unless special arrangements have been made.
  - 3. Maintain in continuous service existing oil and gas pipelines, underground power, telephone or communication cable, water mains, irrigation lines, sewers, poles and overhead power, and other utilities encountered along line of the Work, unless other arrangements satisfactory to owners of said utilities have been made.
  - 4. Where completion of the Work requires temporary or permanent removal or relocation of existing utility, coordinate activities with owner of said utility and perform work to their satisfaction.

5. Protect, shore, brace, support, and maintain underground pipes, conduits, drains, and other underground utility construction uncovered or otherwise affected by construction operations.
  6. Keep fire hydrants and water control valves free from obstruction and available for use at all times.
  7. In areas where Contractor's operations are adjacent to or near a utility, such as gas, telephone, television, electric power, water, sewer, or irrigation system, and such operations may cause damage or inconvenience, suspend operations until arrangements necessary for protection have been made by Contractor.
  8. Notify property owners and utility offices that may be affected by construction operation at least 5 days in advance: Before exposing a utility, obtain utility owner's permission. Should service of utility be interrupted due to Contractor's operation, notify proper authority immediately. Cooperate with said authority in restoring service as promptly as possible and bear costs incurred.
  9. Do not impair operation of existing sewer system. Prevent construction material, pavement, concrete, earth, volatile and corrosive wastes, and other debris from entering sewers, pump stations, or other sewer structures.
  10. Maintain original Site drainage wherever possible.
- B. Site Security: Provide and maintain temporary security fences as necessary to protect the Work and Contractor-furnished products not yet installed.
- C. Barricades and Lights:
1. Provide as required by the FDOT Vehicle Code and in sufficient quantity to safeguard public and the Work.
  2. Provide as necessary to prevent unauthorized entry to construction areas and affected roads, streets, and alleyways, inside and outside of fenced area, and as required to ensure public safety and the safety of Contractor's employees, other employer's employees, and others who may be affected by the Work.
  3. Provide to protect existing facilities and adjacent properties from potential damage.
  4. Locate to enable access by facility operators and property owners.
  5. Protect streets, roads, highways, and other public thoroughfares that are closed to traffic by effective barricades with acceptable warning signs.
  6. Locate barricades at the nearest intersecting public thoroughfare on each side of blocked section.
  7. Illuminate barricades and obstructions with warning lights from sunset to sunrise.



D. Signs and Equipment:

1. Conform to requirements of manual published by the Florida Department of Transportation.
2. Provide at obstructions, such as material piles and equipment.
3. Use to alert general public of construction hazards, which would include surface irregularities, unramped walkways, grade changes, and trenches or excavations in roadways and in other public access areas.

E. Trees and Plantings:

1. Protect from damage and preserve trees, shrubs, and other plants outside limits of the Work and within limits of the Work, which are designated on Drawings to remain undisturbed.
  - a. Where practical, tunnel beneath trees when on or near line of trench.
  - b. Employ hand excavation as necessary to prevent tree injury.
  - c. Do not stockpile materials or permit traffic within drip lines of trees.
  - d. Provide and maintain temporary barricades around trees.
  - e. Water vegetation as necessary to maintain health.
  - f. Cover temporarily exposed roots with wet burlap, and keep burlap moist until soil is replaced around roots.
  - g. No trees, except those specifically shown on Drawings to be removed, shall be removed without written approval of Engineer.
  - h. Dispose of removed trees in a legal manner off the Site.
2. Balling and burlapping of trees indicated for replacement shall conform to recommended specifications set forth in the American Standards for Nursery Stock, published by American Association of Nurserymen. Balls shall be firm and intact and made-balls will not be accepted. Handle ball and burlap trees by ball and not by top.
3. In event of damage to bark, trunks, limbs, or roots of plants that are not designated for removal, treat damage by corrective pruning, bark tracing, application of a heavy coating of tree paint, and other accepted horticultural and tree surgery practices.
4. Replace each plant that dies as a result of construction activities.

F. Existing Structures:

1. Where Contractor contemplates removal of small structures such as mailboxes, signposts, and culverts that interfere with Contractor's operations, obtain approval of property owner and Engineer.
2. Move mailboxes to temporary locations accessible to postal service.
3. Replace items removed in their original location and a condition equal to or better than original.

G. Finished Construction: Protect finished floors and concrete floors exposed as well as those covered with composition tile or other applied surfacing.

- H. Waterways: Keep ditches, culverts, and natural drainages continuously free of construction materials and debris.
- I. Dewatering: Construct, maintain, and operate cofferdams, channels, flume drains, sumps, pumps, or other temporary diversion and protection works. Furnish materials required, install, maintain, and operate necessary pumping and other equipment for the environmentally safe removal and disposal of water from the various parts of the Work. Maintain foundations and parts of the Work free from water.
- J. Archaeological Finds:
  - 1. General: Should finds of an archaeological or paleontological nature be made within Site limits, immediately notify Owner and Engineer and proceed in accordance with General Conditions. Continue the Work in other areas without interruption.
  - 2. Archaeological Finds: Evidence of human occupation or use of an area within contract limits prior to the Year 1840. Evidence may consist of skeletons, stone, or other utensils, or evidence of habitations or structures.
  - 3. Paleontological Finds: Evidence of prehistoric plant or animal life, such as skeletons, bones, fossils, or casts and other indications such as pictographs.
  - 4. Owner may order the Work stopped in other areas if, in Owner's opinion, find is more extensive than may appear from uncovered material.
  - 5. Protection of Finds:
    - a. Cover, fence, or otherwise protect finds until notice to resume the Work is given.
    - b. Cover finds with plastic film held in place by earth, rocks, or other weights placed outside the find. Should additional backfilling be necessary for safety or to prevent caving, place backfill material loosely over plastic film.
    - c. Sheet or shore as necessary to protect excavations underway. Place temporary fence to prevent unauthorized access.
    - d. Dewater finds made below water table as necessary to protect construction Work underway. Divert groundwater or surface runoff away from find by ditching or other acceptable means.
  - 6. Removal of Finds:
    - a. Finds are property of Owner. Do not remove or disturb finds without Owner's written authorization.
    - b. Should Owner elect to have a find removed, provide equipment, labor, and material to permit safe removal of find without damage. Provide transportation for delivery to individuals, institutions, or other places as Owner may find desirable, expedient, or required by law.

K. Endangered and Threatened Species:

1. Take precautions necessary and prudent to protect native endangered and threatened flora and fauna.
2. Notify Engineer of construction activities that might threaten endangered and threatened species or their habitats.
3. Project site is located within a protected wildlife area and the Work therefore shall comply with the National Marine Fisheries Service's "PDCs for In-Water Activities" dated November 20, 2017.
4. The Work shall comply with the National Marine Fisheries Service's "Sea Turtle and Smalltooth Sawfish Construction Conditions" dated March 23, 2006.
5. The Work shall comply with the National Marine Fisheries Service's "Standard Manatee Conditions for In-Water Work" dated April, 2013.

3.03 TEMPORARY CONTROLS

A. Air Pollution Control:

1. Minimize air pollution from construction operations.
2. Burning: No burning is allowed on project site.
3. Conduct operations of dumping rock and of carrying rock away in trucks to cause a minimum of dust. Give unpaved streets, roads, detours, or haul roads used in construction area a dust-preventive treatment or periodically water to prevent dust. Strictly adhere to applicable environmental regulations for dust prevention.

B. Noise Control:

1. Provide acoustical barriers so noise emanating from tools or equipment will not exceed legal noise levels.
2. Noise Control Ordinance: City of Fort Walton Beach.

C. Water Pollution Control:

1. Divert sanitary sewage and nonstorm waste flow interfering with construction and requiring diversion to sanitary sewers. Do not cause or permit action to occur which would cause an overflow to existing waterway.
2. Prior to commencing excavation and construction, obtain Engineer's agreement with detailed plans showing procedures intended to handle and dispose of sewage, groundwater, and dewatering pump discharges.
3. Comply with Section 01 57 13, Temporary Erosion and Sediment Control, for stormwater flow and surface runoff.

4. Do not dispose of volatile wastes such as mineral spirits, oil, chemicals, or paint thinner in storm or sanitary drains. Disposal of wastes into streams or waterways is prohibited. Provide acceptable containers for collection and disposal of waste materials, debris, and rubbish.

- D. Erosion, Sediment, and Flood Control: Provide, maintain, and operate temporary facilities as specified in Section 01 57 13, Temporary Erosion and Sediment Control, to control erosion and sediment releases, and to protect the Work and existing facilities from flooding during construction period.

### 3.04 HOURS OF OPERATION

- A. Typical business hours:
  1. HDD operations: 24-hour continuous operation.
  2. All work other than HDD operations: typical business hours between Monday – Friday 7:00 a.m. – 5:00 p.m. No work will be allowed on weekends or Holidays.
- B. Contractor may provide written request for permission to work outside these typical business hours.

### 3.05 PARKING AREAS

- A. Control vehicular parking to preclude interference with public traffic or parking, access by emergency vehicles, Owner's operations, or construction operations.

### 3.06 VEHICULAR TRAFFIC

- A. Contractor to design a detailed Traffic and Pedestrian Control Plan signed by a Florida P.E.
- B. Comply with Laws and Regulations regarding closing or restricting use of public streets or highways. No public or private road shall be closed without providing an adequate detour route. Ensure the least possible obstruction to traffic and normal commercial pursuits.
- C. Conduct the Work to interfere as little as possible with public travel, whether vehicular or pedestrian.
- D. Whenever it is necessary to cross, close, or obstruct roads, driveways, and walks, whether public or private, provide and maintain suitable and safe bridges, detours, or other temporary expedients for accommodation of public and private travel.

- E. All work and pipe staging is to be done within property and highway right-of-ways. Closing lanes of Santa Rosa Blvd is not permitted. Pipe staging alignment may only impact local arterial streets per previous requirements.
- F. Maintain top of backfilled trenches before they are paved, to allow normal vehicular traffic to pass over. Provide temporary access driveways where required. Cleanup operations shall follow immediately behind backfilling.
- G. When flaggers and guards are required by regulation or when deemed necessary for safety, furnish them with approved orange wearing apparel and other regulation traffic control devices.
- H. Notify fire department and police department before closing street or portion thereof. Notify said departments when streets are again passable for emergency vehicles. Do not block off emergency vehicle access to consecutive arterial crossings or dead-end streets, in excess of 300 linear feet, without written permission from fire department. Conduct operations with the least interference to fire equipment access, and at no time prevent such access. Furnish Contractor's night emergency telephone numbers to police department.
- I. Detours:
  - 1. Where authority having jurisdiction requires that traffic be maintained over construction work in a public street, road, or highway, and traffic cannot be maintained on original roadbed or pavement, construct and maintain detour around the Work.
  - 2. Provide lighted signage for directing traffic.
  - 3. Proposed fused pipe staging alignment restricts access to Bluefish Drive East requiring detouring to Bluefish Drive West.
- J. Coordinate traffic routing with that of others working in same or adjacent areas.

### 3.07 CLEANING DURING CONSTRUCTION

- A. In accordance with General Conditions, as may be specified in other Specification sections, and as required herein.
- B. Wet down exterior surfaces prior to sweeping to prevent blowing of dust and debris. At least weekly, sweep floors (basins, tunnels, platforms, walkways, roof surfaces), and pick up and dispose of debris.
- C. Provide approved containers for collection and disposal of waste materials, debris, and rubbish. At least weekly, dispose of such waste materials, debris, and rubbish offsite.

- D. At least weekly, brush sweep entry drive, roadways, and other streets and walkways affected by the Work and where adjacent to the Work.

3.08 SUPPLEMENTS

- A. The supplements listed below, following “END OF SECTION,” are part of this Specification.
  - 1. PDCs for In-Water Activities.
  - 2. Standard Manatee Conditions for In-Water Work.
  - 3. Sea Turtle and Sawtooth Construction Conditions.

**END OF SECTION**

For an activity to be covered under this Opinion, the USACE authorization must include the following conditions. Failure to comply with these conditions could result in enforcement action by the USACE and/or NMFS.

**AP.7. Education and Observation:** The permittee must ensure that all personnel associated with the project are instructed about the potential presence of species protected under the ESA and the Marine Mammal Protection Act (MMPA). All on-site project personnel are responsible for observing water-related activities for the presence of protected species. All personnel shall be advised that there are civil and criminal penalties for harming, harassing, or killing ESA-listed species or marine mammals. To determine which species may be found in the project area, please review the relevant Protected Species List at: [http://sero.nmfs.noaa.gov/protected\\_resources/section\\_7/threatened\\_endangered/index.html](http://sero.nmfs.noaa.gov/protected_resources/section_7/threatened_endangered/index.html)

**AP.8. Reporting** of interactions with protected species:

- a) Any collision(s) with and/or injury to any sea turtle, sawfish, whale, or sturgeon occurring during the construction of a project, shall be reported immediately to NMFS's Protected Resources Division (PRD) at (1-727-824-5312) or by email to [takereport.nmfsser@noaa.gov](mailto:takereport.nmfsser@noaa.gov) and [SAJ-RD-Enforcement@usace.army.mil](mailto:SAJ-RD-Enforcement@usace.army.mil).
- b) Smalltooth sawfish: Report sightings to 1-844-SAWFISH or email [Sawfish@MyFWC.com](mailto:Sawfish@MyFWC.com)
- c) Sturgeon: Report dead sturgeon to 1-844-STURG 911 (1-844-788-7491) or email [nmfs.ser.sturgeonnetwork@noaa.gov](mailto:nmfs.ser.sturgeonnetwork@noaa.gov)
- d) Sea turtles and marine mammals: Report stranded, injured, or dead animals to 1-877-WHALE HELP (1-877-942-5343).
- e) North Atlantic right whale: Report injured, dead, or entangled right whales to the USCG via VHF Channel 16.

**AP.9. Vessel Traffic and Construction Equipment:** All vessel operators must watch for and avoid collision with species protected under the ESA and MMPA. Vessel operators must avoid potential interactions with protected species and operate in accordance with the following protective measures:

- a) *Construction Equipment:*
  - i) All vessels associated with the construction project shall operate at "Idle Speed/No Wake" at all times while operating in water depths where the draft of the vessel provides less than a 4-foot (ft) clearance from the bottom, and in all depths after a protected species has been observed in and has departed the area.
  - ii) All vessels will follow marked channels and/or routes using the maximum water depth whenever possible.
  - iii) Operation of any mechanical construction equipment, including vessels, shall cease immediately if a listed species is observed within a 50-ft radius of construction equipment and shall not resume until the species has departed the area of its own volition.

- iv) If the detection of species is not possible during certain weather conditions (e.g., fog, rain, wind), then in-water operations will cease until weather conditions improve and detection is again feasible.
- b) *All Vessels:*
  - i) Sea turtles: Maintain a minimum distance of 150 ft.
  - ii) North Atlantic right whale: Maintain a minimum 1,500-ft distance (500 yards).
  - iii) Vessels 65 ft in length or longer must comply with the Right Whale Ship Strike Reduction Rule (50 CFR 224.105) which includes reducing speeds to 10 knots or less in Seasonal Management Areas (<http://www.fisheries.noaa.gov/pr/shipstrike/>).
  - iv) Mariners shall check various communication media for general information regarding avoiding ship strikes and specific information regarding right whale sightings in the area. These include NOAA weather radio, USCG NAVTEX broadcasts, and Notices to Mariners.
  - v) Marine mammals (i.e., dolphins, whales [other than North Atlantic right whales], and porpoises): Maintain a minimum distance of 300 ft.
  - vi) When these animals are sighted while the vessel is underway (e.g., bow-riding), attempt to remain parallel to the animal's course. Avoid excessive speed or abrupt changes in direction until they have left the area.
  - vii) Reduce speed to 10 knots or less when mother/calf pairs or groups of marine mammals are observed, when safety permits.

**AP.10. Turbidity Control Measures during Construction:** Turbidity must be monitored and controlled. Prior to initiating any of the work covered under this Opinion, the Permittee shall install turbidity curtains as described below. In some instances, the use of turbidity curtains may be waived by the USACE project manager if the project is deemed too minimal to generate turbidity (e.g., certain ATON installation, scientific survey device placement, marine debris removal) or if the current is too strong for the curtains to stay in place. Turbidity curtains specifications:

- a) Install floating turbidity barriers with weighted skirts that extend to within 1 ft of the bottom around all work areas that are in, or adjacent to, surface waters.
- b) Use these turbidity barriers throughout construction to control erosion and siltation and ensure that turbidity levels within the project area do not exceed background conditions.
- c) Position turbidity barriers in a way that does not block species' entry to or exit from designated critical habitat.
- d) Monitor and maintain turbidity barriers in place until the authorized work has been completed and the water quality in the project area has returned to background conditions.
- e) In the range of ESA-listed corals (St. Lucie Inlet, Martin County south to the Dry Tortugas and the U.S. Caribbean) and Johnson's seagrass (Turkey Creek/Palm Bay south to central Biscayne Bay in the lagoon systems on the east coast of Florida):
  - Projects that include upland earth moving (e.g., grading to install a building or parking lot associated with a dock and seawall project), must install sediment control barriers to prevent any upland sediments from reaching estuarine or marine waters.
  - The turbidity curtain requirement cannot be waived for any project that moves or removes sediment (e.g., dredging, auger to create a pile, trenching to install a cable line). If turbidity curtains are not feasible in an area based on site conditions such as water current, high wave action, or stormy conditions, the project must undergo individual Section 7 consultation and is not covered under this Programmatic Opinion.



**AP.11. Entanglement:** All turbidity curtains and other in-water equipment must be properly secured with materials that reduce the risk of entanglement of marine species (described below). Turbidity curtains likewise must be made of materials that reduce the risk of entanglement of marine species.

- a) In-water lines (rope, chain, and cable, including the lines to secure turbidity curtains) must be stiff, taut, and non-looping. Examples of such lines are heavy metal chains or heavy cables that do not readily loop and tangle. Flexible in-water lines, such as nylon rope or any lines that could loop or tangle, must be enclosed in a plastic or rubber sleeve/tube to add rigidity and prevent the line from looping and tangling. In all instances, no excess line is allowed in the water.
- b) Turbidity curtains and other in-water equipment must be placed in a manner that does not entrap species within the construction area or block access for them to navigate around the construction area.



## STANDARD MANATEE CONDITIONS FOR IN-WATER WORK

2013

The permittee shall comply with the following conditions intended to protect manatees from direct project effects:

- a. All personnel associated with the project shall be instructed about the presence of manatees and manatee speed zones, and the need to avoid collisions with and injury to manatees. The permittee shall advise all construction personnel that there are civil and criminal penalties for harming, harassing, or killing manatees which are protected under the Marine Mammal Protection Act, the Endangered Species Act, and the Florida Manatee Sanctuary Act.
- b. All vessels associated with the construction project shall operate at "Idle Speed/No Wake" at all times while in the immediate area and while in water where the draft of the vessel provides less than a four-foot clearance from the bottom. All vessels will follow routes of deep water whenever possible.
- c. Siltation or turbidity barriers shall be made of material in which manatees cannot become entangled, shall be properly secured, and shall be regularly monitored to avoid manatee entanglement or entrapment. Barriers must not impede manatee movement.
- d. All on-site project personnel are responsible for observing water-related activities for the presence of manatee(s). All in-water operations, including vessels, must be shutdown if a manatee(s) comes within 50 feet of the operation. Activities will not resume until the manatee(s) has moved beyond the 50-foot radius of the project operation, or until 30 minutes elapses if the manatee(s) has not reappeared within 50 feet of the operation. Animals must not be herded away or harassed into leaving.
- e. Any collision with or injury to a manatee shall be reported immediately to the Florida Fish and Wildlife Conservation Commission (FWC) Hotline at 1-888-404-3922. Collision and/or injury should also be reported to the U.S. Fish and Wildlife Service in Jacksonville (1-904-731-3336) for north Florida or Vero Beach (1-772-562-3909) for south Florida, and to FWC at [ImperiledSpecies@myFWC.com](mailto:ImperiledSpecies@myFWC.com)
- f. Temporary signs concerning manatees shall be posted prior to and during all in-water project activities. All signs are to be removed by the permittee upon completion of the project. Temporary signs that have already been approved for this use by the FWC must be used. One sign which reads *Caution: Boaters* must be posted. A second sign measuring at least 8 ½" by 11" explaining the requirements for "Idle Speed/No Wake" and the shut down of in-water operations must be posted in a location prominently visible to all personnel engaged in water-related activities. These signs can be viewed at [MyFWC.com/manatee](http://MyFWC.com/manatee). Questions concerning these signs can be sent to the email address listed above.





**UNITED STATES DEPARTMENT OF COMMERCE**  
**National Oceanic and Atmospheric Administration**  
**NATIONAL MARINE FISHERIES SERVICE**  
Southeast Regional Office  
263 13th Avenue South  
St. Petersburg, FL 33701

## **SEA TURTLE AND SMALLTOOTH SAWFISH CONSTRUCTION CONDITIONS**

The permittee shall comply with the following protected species construction conditions:

- a. The permittee shall instruct all personnel associated with the project of the potential presence of these species and the need to avoid collisions with sea turtles and smalltooth sawfish. All construction personnel are responsible for observing water-related activities for the presence of these species.
- b. The permittee shall advise all construction personnel that there are civil and criminal penalties for harming, harassing, or killing sea turtles or smalltooth sawfish, which are protected under the Endangered Species Act of 1973.
- c. Siltation barriers shall be made of material in which a sea turtle or smalltooth sawfish cannot become entangled, be properly secured, and be regularly monitored to avoid protected species entrapment. Barriers may not block sea turtle or smalltooth sawfish entry to or exit from designated critical habitat without prior agreement from the National Marine Fisheries Service's Protected Resources Division, St. Petersburg, Florida.
- d. All vessels associated with the construction project shall operate at "no wake/idle" speeds at all times while in the construction area and while in water depths where the draft of the vessel provides less than a four-foot clearance from the bottom. All vessels will preferentially follow deep-water routes (e.g., marked channels) whenever possible.
- e. If a sea turtle or smalltooth sawfish is seen within 100 yards of the active daily construction/dredging operation or vessel movement, all appropriate precautions shall be implemented to ensure its protection. These precautions shall include cessation of operation of any moving equipment closer than 50 feet of a sea turtle or smalltooth sawfish. Operation of any mechanical construction equipment shall cease immediately if a sea turtle or smalltooth sawfish is seen within a 50-ft radius of the equipment. Activities may not resume until the protected species has departed the project area of its own volition.
- f. Any collision with and/or injury to a sea turtle or smalltooth sawfish shall be reported immediately to the National Marine Fisheries Service's Protected Resources Division (727-824-5312) and the local authorized sea turtle stranding/rescue organization.
- g. Any special construction conditions, required of your specific project, outside these general conditions, if applicable, will be addressed in the primary consultation.

Revised: March 23, 2006

O:\forms\Sea Turtle and Smalltooth Sawfish Construction Conditions.doc





**SECTION 01 57 13**  
**TEMPORARY EROSION AND SEDIMENT CONTROL**

**PART 1 GENERAL**

1.01 SUMMARY

- A. This section covers Work to implement structural and nonstructural Best Management Practices (BMP) to control soil erosion by wind or water and keep eroded sediments and other construction-generated pollutants from moving off project sites. Requirements described in this specification and shown on the Drawings are part of the project Temporary Erosion and Sediment Control Plan (TESC Plan) and are the minimum for all project construction sites and conditions. This specification covers all project activities, including material sources, disposal sites, and offsite mitigation areas unless specific project activities are excluded elsewhere in this specification or in other Contract Documents controlling the Work.
- B. National Pollutant Discharge Elimination System: Comply with Federal, state, and local laws, rules and regulations.
- C. Other Regulations: Adequate erosion and sediment control is essential for complying with the federal Endangered Species Act where construction runoff enters waters inhabited by protected species.

1.02 REFERENCES

- A. Activities shall conform to the Florida Erosion and Sediment Control Manual, and Drawings. In the event of a conflict, the more stringent requirement shall apply.
- B. The following is a list of standards that may be referenced in this section:
  - 1. American Association of State Highway and Transportation Officials (AASHTO): M252, Standard Specification for Corrugated Polyethylene Drainage Pipe.
  - 2. ASTM International (ASTM):
    - a. D638, Standard Test Method for Tensile Properties of Plastics.
    - b. D2974, Standard Test Methods for Moisture, Ash, and Organic Matter of Peat and Other Organic Soils.
    - c. D3776/D3776M, Standard Test Methods for Mass Per Unit Area (Weight) of Fabric.
    - d. D4355, Standard Test Method for Deterioration of Geotextiles by Exposure to Light, Moisture and Heat in a Xenon Arc Type Apparatus.

- e. D4397, Standard Specification for Polyethylene Sheeting for Construction, Industrial, and Agricultural Applications.
  - f. D4491, Standard Test Methods for Water Permeability of Geotextiles by Permittivity.
  - g. D4533, Standard Test Method for Trapezoid Tearing Strength of Geotextiles.
  - h. D4632/D4632M, Standard Test Method for Grab Breaking Load and Elongation of Geotextiles.
  - i. D4751, Standard Test Method for Determining Apparent Opening Size of a Geotextile
  - j. D6241, Standard Test Method for Static Puncture Strength of Geotextiles and Geotextile-Related Products Using a 50-mm Probe.
  - k. D6459, Standard Test Method for Determination of Rolled Erosion Control Product (RECP) Performance in Protecting Hillslopes from Rainfall-Induced Erosion.
  - l. D6460, Standard Test Method for Determination of Rolled Erosion Control Product (RECP) Performance in Protecting Earthen Channels from Stormwater-Induced Erosion.
  - m. D6475, Standard Test Method for Measuring Mass Per Unit Area of Erosion Control Blankets.
  - n. D7322, Standard Test Method for Determination of Rolled Erosion Control Product (RECP) Ability to Encourage Seed Germination and Plant Growth Under Bench-Scale Conditions.
  - o. D7367, Standard Test Method for Determining Water Holding Capacity of Fiber Mulches for Hydraulic Planting.
- 3. National Weather Service:
    - a. Precipitation-Frequency of the United States by State/Territory, 2012.
    - b. Precipitation Frequency Data Server, 2012.
  - 4. North American Weed Management Association (NAWMA).
  - 5. U.S. Department of Agriculture, Natural Resources Conservation Service: *Urban Hydrology for Small Watersheds*; 1986. Technical Release 55.
  - 6. U.S. Environmental Protection Agency:
    - a. Developing Your Stormwater Pollution Prevention Plan: A Guide for Construction Sites, 2007. EPA-833-R-06-004.
    - b. National Menu of BMPs, 2012.

### 1.03 SYSTEM DESCRIPTION

- A. Erosion and Sediment Control: Provide, maintain, and operate temporary facilities to control erosion and sediment releases during construction period.



- B. Install high visibility fence along the Site preservation lines shown on the Drawings or as instructed by Engineer. Space posts and attach fence fabric to posts as shown on the Drawings. Do not fasten fence to trees. Throughout the life of the Project, preserve and protect delineated area, acting immediately to repair or restore any fencing damaged or removed.
- C. Preventing erosion, and controlling runoff, sedimentation, and non-stormwater pollution, requires Contractor to perform temporary Work items including, but not limited to:
  - 1. Construction of temporary erosion control facilities such as silt fences, wattles, or check dams.
  - 2. Placement and maintenance of temporary seeding on grassed areas disturbed by construction.
- D. Pollution Control: Use BMPs to prevent or minimize stormwater exposure to pollutants from construction activities such as but not limited to HDD drilling mud waste and equipment. Nothing in this section shall relieve Contractor from complying with other Contract requirements.

#### 1.04 SUBMITTALS

- A. Informational Submittals: BMP Plan prepared in accordance with the requirements of FDEP.

### **PART 2 PRODUCTS**

#### 2.01 HIGH VISIBILITY FENCING PERIMETER FENCING

- A. High Visibility Fence: UV stabilized, orange, high-density polyethylene or polypropylene mesh.
- B. Height: 4 feet minimum.
- C. Support Posts: Wood or steel with sufficient strength and durability to support the fence through the life of the Project.

#### 2.02 INLET PROTECTION

- A. As shown on Drawings.

#### 2.03 SILT (SEDIMENT) FENCE

- A. As shown on Drawings.

2.04 WATTLES

- A. Cylinders of biodegradable plant material such as weed-free straw, coir, compost, wood chips, excelsior, or wood fiber or shavings encased within biodegradable netting.
- B. Diameter: 5 inches minimum.
- C. Netting Material: Clean, evenly woven, and free of encrusted concrete or other contaminating materials such as preservatives. Also, free from cuts, tears, or weak places with a minimum lifespan of 6 months.
- D. Compost Filler: Coarse compost, wood chips, or wood shavings.
- E. Wood Stakes: Untreated softwood species, 2-inch by 2-inch nominal dimension and 36 inches in length.

**PART 3 EXECUTION**

3.01 PREPARATION

- A. Include proposed stockpile areas and installation of temporary erosion control devices, ditches, or other facilities in Work phasing plans.
- B. Areas designated for Contractor's use during Project may be temporarily developed as specified to provide working, staging, and administrative areas. Include control of sediment from these areas in the submitted Drawing.
- C. Inlet Protection: Install inlet protection below or above, or as a prefabricated cover at each inlet grate, as shown on the Drawings. Install inlet protection devices prior to beginning work activities. Geotextile fabric used in prefabricated inlet protection devices must meet or exceed the requirements for Moderate Survivability and minimum filtration properties. When depth of accumulated sediment and debris reaches approximately one-half the height of an internal device or one-third the height of external device (or less when so specified by the manufacturers) or as designated by Engineer, remove deposits and stabilize onsite.
  - 1. Above Inlet Grate:
    - a. Devices may be silt fence, sandbags, or prefabricated units specifically designed for inlet protection.
    - b. Must remain securely in place around drainage structure under all conditions.

D. Silt (Sediment) Fence:

1. Silt fence shall be installed in accordance with the Drawings. When backup support is used, use steel wire with a maximum mesh spacing of 2 inches by 4 inches, or plastic mesh as resistant to ultraviolet radiation as the geotextile it supports. Provide wire or plastic mesh with strength equivalent to or greater than as required for unsupported geotextile (for example, 180 pounds grab tensile strength in the machine direction).
2. Attach geotextile to posts and support system using staples, wire, or in accordance with manufacturer's recommendations. Geotextile shall be sewn together at the point of manufacture, or at a location approved by Engineer, to form geotextile lengths as required.
3. Provide wood or steel support posts at sewn seams and overlaps and as shown on the Drawings and necessary to support fence.
4. Wood Posts: Minimum dimensions of 1-1/4-inch by 1-1/4-inch by the minimum length shown on the Drawings.
5. Steel Posts: Minimum weight of 0.90 lb/ft.
6. When sediment deposits reach approximately one-third the height of the silt fence, remove and stabilize deposits.

- E. Wattles: Install wattles as soon as construction will allow or when designated by Engineer. Begin trench construction and wattle installation at base of slope and work uphill. Spread excavated material evenly along the uphill slope and compact using hand tamping or other method approved by Engineer. On gradually sloped or clay-type soils, provide trenches 2 inches to 3 inches deep. On loose soils, in high rainfall areas, or on steep slopes, provide trenches 3 inches to 5 inches deep, or half the thickness of the wattle. Exercise care when installing wattles to minimize disturbance of waterways and prevent sediment or pollutant discharge into waterbodies.

### 3.02 MAINTENANCE

- A. The measures described in this specification are minimum requirements for anticipated Site conditions. During the construction period, upgrade these measures as needed to comply with all applicable local, state, and federal erosion and sediment control regulations.
- B. Maintain erosion and sediment control BMPs so they properly perform their function until construction activities are complete and project site is restored.
- C. Construction activities must avoid or minimize excavation and creation of bare ground during wet weather.
- D. The intentional washing of sediment into storm sewers or drainage ways must not occur. Vacuuming or dry sweeping and material pickup must be used to cleanup released sediments.

- E. Unless otherwise specified, remove deposits before the depth of accumulated sediment and debris reaches approximately height of BMP. Dispose of debris or contaminated sediment at approved locations. Clean sediments may be stabilized onsite using BMPs as approved by Engineer.
- F. Sediment Fence: Remove trapped sediment before it reaches one-third of the above ground fence height and before fence removal.
- G. Other Sediment Barriers (such as biobags): Remove sediment before it reaches 2 inches depth above ground height and before BMP removal.
- H. Initiate repair or replacement of damaged erosion and sediment control BMPs immediately.

3.03 CLEANING

- A. Dress soil deposits remaining after fence has been removed to conform to existing grade. Prepare and seed graded area.

**END OF SECTION**

**SECTION 01 77 00  
CLOSEOUT PROCEDURES**

**PART 1 GENERAL**

1.01 SUBMITTALS

A. Informational Submittals:

1. Submit prior to application for final payment.
  - a. Record Documents: As required in General Conditions.
  - b. Special bonds, Special Guarantees, and Service Agreements.
  - c. Consent of Surety to Final Payment: As required in General Conditions.
  - d. Releases or Waivers of Liens and Claims: As required in General Conditions.
  - e. Releases from Agreements.
  - f. Final Application for Payment: Submit in accordance with procedures and requirements stated in Section 01 29 00, Payment Procedures.
  - g. Extra Materials: As required by individual Specification sections.

1.02 RECORD DOCUMENTS

A. Quality Assurance:

1. Furnish qualified and experienced person, whose duty and responsibility shall be to maintain record documents.
2. Accuracy of Records:
  - a. Coordinate changes within record documents, making legible and accurate entries on each sheet of Drawings and other documents where such entry is required to show change.
  - b. Purpose of Project record documents is to document factual information regarding aspects of the Work, both concealed and visible, to enable future modification of the Work to proceed without lengthy and expensive Site measurement, investigation, and examination.
3. Make entries within 24 hours after receipt of information that a change in the Work has occurred.
4. Prior to submitting each request for progress payment, request Engineer's review and approval of current status of record documents. Failure to properly maintain, update, and submit record documents may result in a deferral by Engineer to recommend whole or any part of Contractor's Application for Payment, either partial or final.

1.03 RELEASES FROM AGREEMENTS

- A. Furnish Owner written releases from property owners or public agencies where side agreements or special easements have been made, or where Contractor's operations have not been kept within the Owner's construction right-of-way.
- B. In the event Contractor is unable to secure written releases:
  - 1. Inform Owner of the reasons.
  - 2. Owner or its representatives will examine the Site, and Owner will direct Contractor to complete the Work that may be necessary to satisfy terms of the side agreement or special easement.
  - 3. Should Contractor refuse to perform this Work, Owner reserves right to have it done by separate contract and deduct cost of same from Contract Price, or require Contractor to furnish a satisfactory bond in a sum to cover legal Claims for damages.
  - 4. When Owner is satisfied that the Work has been completed in agreement with Contract Documents and terms of side agreement or special easement, right is reserved to waive requirement for written release if: (i) Contractor's failure to obtain such statement is due to grantor's refusal to sign, and this refusal is not based upon any legitimate Claims that Contractor has failed to fulfill terms of side agreement or special easement, or (ii) Contractor is unable to contact or has had undue hardship in contacting grantor.

**PART 2 PRODUCTS (NOT USED)**

**PART 3 EXECUTION**

3.01 MAINTENANCE OF RECORD DOCUMENTS

- A. General:
  - 1. Promptly following commencement of Contract Times, secure from Engineer at no cost to Contractor, one complete set of Contract Documents.
  - 2. Label or stamp each record document with title, "RECORD DOCUMENTS," in neat large printed letters.
  - 3. Record information concurrently with construction progress and within 24 hours after receipt of information that change has occurred. Do not cover or conceal Work until required information is recorded.

B. Preservation:

1. Maintain documents in a clean, dry, legible condition and in good order. Do not use record documents for construction purposes.
2. Make documents and Samples available at all times for observation by Engineer.

C. Making Entries on Drawings:

1. Using an erasable colored pencil (not ink or indelible pencil), clearly describe change by graphic line and note as required.
  - a. Color Coding:
    - 1) Green when showing information deleted from Drawings.
    - 2) Red when showing information added to Drawings.
    - 3) Blue and circled in blue to show notes.
2. Date entries.
3. Call attention to entry by “cloud” drawn around area or areas affected.
4. Legibly mark to record actual changes made during construction, including, but not limited to:
  - a. Depths of various elements of foundation in relation to finished first floor data if not shown or where depth differs from that shown.
  - b. Horizontal and vertical locations of existing and new Underground Facilities and appurtenances, and other underground structures, equipment, or Work. Reference to at least two measurements to permanent surface improvements.
  - c. Location of internal utilities and appurtenances concealed in the construction referenced to visible and accessible features of the structure.
  - d. Locate existing facilities, piping, equipment, and items critical to the interface between existing physical conditions or construction and new construction.
  - e. Changes made by Addenda and Field Orders, Work Change Directive, Change Order, and Engineer’s written interpretation and clarification using consistent symbols for each and showing appropriate document tracking number.
5. Dimensions on Schematic Layouts: Show on record drawings, by dimension, the centerline of each run of items such as are described in previous subparagraph above.
  - a. Clearly identify the item by accurate note such as “cast iron drain,” “galv. water,” and the like.
  - b. Show, by symbol or note, vertical location of item (“under slab,” “in ceiling plenum,” “exposed,” and the like).
  - c. Make identification so descriptive that it may be related reliably to Specifications.

3.02 FINAL CLEANING

- A. At completion of the Work or of a part thereof and immediately prior to Contractor's request for certificate of Substantial Completion; or if no certificate is issued, immediately prior to Contractor's notice of completion, clean entire Site or parts thereof, as applicable.
  - 1. Leave the Work and adjacent areas affected in a cleaned condition satisfactory to Owner.
  - 2. Remove grease, dirt, dust, paint or plaster splatter, stains, labels, fingerprints, and other foreign materials from exposed surfaces.
  - 3. Repair, patch, and touch up marred surfaces to specified finish and match adjacent surfaces.
  - 4. Broom clean exterior paved driveways and parking areas.
  - 5. Hose clean sidewalks, loading areas, and others contiguous with principal structures.
  - 6. Rake clean all other surfaces.
  - 7. Leave water courses, gutters, and ditches open and clean.
- B. Use only cleaning materials recommended by manufacturer of surfaces to be cleaned.

**END OF SECTION**



**SECTION 31 23 23.15  
TRENCH BACKFILL**

**PART 1 GENERAL**

1.01 REFERENCES

A. The following is a list of standards which may be referenced in this section:

1. American Public Works Association (APWA): Uniform Color Code.
2. ASTM International (ASTM):
  - a. C33/C33M, Standard Specification for Concrete Aggregates.
  - b. C94/C94M, Standard Specification for Ready-Mixed Concrete.
  - c. C117, Standard Test Method for Materials Finer than 75 Micrometer (No. 200) Sieve in Mineral Aggregates by Washing.
  - d. C136, Standard Test Method for Sieve Analysis of Fine and Coarse Aggregates.
  - e. C150/C150M, Standard Specification for Portland Cement.
  - f. C618, Standard Specification for Coal Fly Ash and Raw or Calcined Natural Pozzolan for Use in Concrete.
  - g. C1012/C1012M, Standard Test Method for Length Change of Hydraulic-Cement Mortars Exposed to a Sulfate Solution.
  - h. D698, Standard Test Methods for Laboratory Compaction Characteristics of Soil Using Standard Effort (12,400 ft-lbf/ft<sup>3</sup> (600 kN-m/m<sup>3</sup>)).
  - i. D1140, Standard Test Methods for Amount of Material in Soils Finer than No. 200 (75 micrometer) Sieve.
  - j. D1557, Standard Test Methods for Laboratory Compaction Characteristics of Soil using Modified Effort (56,000 ft-lbf/ft<sup>3</sup> (2,700 kN-m/m<sup>3</sup>)).
  - k. D2487, Standard Practice for Classification of Soils for Engineering Purposes (Unified Soil Classification System).
  - l. D4253, Standard Test Methods for Maximum Index Density and Unit Weight of Soils Using a Vibratory Table.
  - m. D4254, Standard Test Methods for Minimum Index Density and Unit Weight of Soils and Calculation of Relative Density.
  - n. D4318, Standard Test Methods for Liquid Limit, Plastic Limit, and Plasticity Index of Soils.
  - o. D4832, Standard Test Method for Preparation and Testing of Controlled Low Strength Material (CLSM) Test Cylinders.

1.02 DEFINITIONS

- A. Base Rock: Granular material upon which manhole bases and other structures are placed.
- B. Bedding Material: Granular material upon which pipes, conduits, cables, or duct banks are placed.
- C. Imported Material: Material obtained by Contractor from source(s) offsite.
- D. Lift: Loose (uncompacted) layer of material.
- E. Pipe Zone: Backfill zone that includes full trench width and extends from prepared trench bottom to an upper limit above top outside surface of pipe, conduit, cable or duct bank.
- F. Prepared Trench Bottom: Graded trench bottom after excavation and installation of stabilization material, if required, but before installation of bedding material.
- G. Relative Compaction: The ratio, in percent, of the as-compacted field dry density to the laboratory maximum dry density as determined by ASTM D1557. Corrections for oversize material may be applied to either as-compacted field dry density or maximum dry density, as determined by Engineer.
- H. Relative Density: As defined by ASTM D4253 and ASTM D4254.
- I. Selected Backfill Material: Material available onsite that Engineer determines to be suitable for a specific use.
- J. Well-Graded: A mixture of particle sizes that has no specific concentration or lack thereof of one or more sizes producing a material type that, when compacted, produces a strong and relatively incompressible soil mass free from detrimental voids. Satisfying both of the following requirements, as defined in ASTM D2487:
  - 1. Coefficient of Curvature: Greater than or equal to 1 and less than or equal to 3.
  - 2. Coefficient of Uniformity: Greater than or equal to 4 for materials classified as gravel, and greater than or equal to 6 for materials classified as sand.

**PART 2 PRODUCTS****2.01 MARKING TAPE****A. Detectable:**

1. Solid aluminum foil, visible on unprinted side, encased in protective high visibility, inert polyethylene plastic jacket.
2. Foil Thickness: Minimum 0.35 mils.
3. Laminate Thickness: Minimum 5 mils.
4. Width: 6 inches.
5. Identifying Lettering: Minimum 1-inch high, permanent black lettering imprinted continuously over entire length.
6. Joining Clips: Tin or nickel-coated furnished by tape manufacturer.
7. Manufacturers and Products:
  - a. Reef Industries; Terra Tape, Sentry Line Detectable.
  - b. Mutual Industries; Detectable Tape.
  - c. Presco; Detectable Tape.

**B. Color: In accordance with APWA Uniform Color Code.**

<b>Color*</b>	<b>Facility</b>
Blue	Potable water
*As specified in NEMA Z535.1, Safety Color Code.	

**2.02 TRENCH STABILIZATION MATERIAL****A. Granular Backfill:**

1. Clean gravel or crushed rock, reasonably well-graded from coarse to fine.
2. Maximum Particle Size: 1-inch.
3. Dry sand, accepted by Engineer, may be provided for trenches above maximum groundwater level.

**2.03 BEDDING MATERIAL AND PIPE ZONE MATERIAL**

- A. Unfrozen, friable, and no clay balls, roots, or other organic material.
- B. Clean or gravelly sand with less than 5 percent passing No. 200 sieve, as determined in accordance with ASTM D1140.

**2.04 EARTH BACKFILL**

- A. Soil, loam, or other excavated material suitable for use as backfill.
- B. Free from roots or organic matter, refuse, boulders and material larger than 1/2 cubic foot, or other deleterious materials.

2.05 CONCRETE BACKFILL

- A. Mix: ASTM C94/C94M, Option A.
  - 1. Cement: ASTM C150/C150M, Type I or Type II.
  - 2. Coarse Aggregate Size: 1-1/2 inches.
  - 3. Design for Minimum Compressive Strength at 28 Days: 2,500 psi.

**PART 3 EXECUTION**

3.01 TRENCH PREPARATION

- A. Water Control:
  - 1. Remove water in a manner that minimizes soil erosion from trench sides and bottom.
  - 2. Provide continuous water control until trench backfill is complete.
- B. Remove foreign material and backfill contaminated with foreign material that falls into trench.

3.02 TRENCH BOTTOM

- A. Firm Subgrade: Grade with hand tools, remove loose and disturbed material, and trim off high areas and ridges left by excavating bucket teeth. Allow space for bedding material if shown or specified.
- B. Soft Subgrade: If subgrade is encountered that may require removal to prevent pipe settlement, notify Engineer. Engineer will determine depth of overexcavation, if any required.

3.03 TRENCH STABILIZATION MATERIAL INSTALLATION

- A. Rebuild trench bottom with trench stabilization material.
- B. Place material over full width of trench in 6-inch lifts to required grade, providing allowance for bedding thickness.
- C. Compact each lift so as to provide a firm, unyielding support for the bedding material prior to placing succeeding lifts.

3.04 BEDDING

- A. Furnish imported bedding material where, in the opinion of Engineer, excavated material is unsuitable for bedding or insufficient in quantity.
- B. Place over full width of prepared trench bottom in two equal lifts when required depth exceeds 8 inches.

- C. Hand grade and compact each lift to provide a firm, unyielding surface.
- D. Minimum Thickness: 4 inches.
- E. Check grade and correct irregularities in bedding material. Loosen top 1 inch to 2 inches of compacted bedding material with a rake or by other means to provide a cushion before laying each section of pipe, conduit, direct-buried cable, or duct bank.
- F. Install to form continuous and uniform support except at bell holes, if applicable, or minor disturbances resulting from removal of lifting tackle.
- G. Bell or Coupling Holes: Excavate in bedding at each joint to permit proper assembly and inspection of joint and to provide uniform bearing along barrel of pipe or conduit.

### 3.05 BACKFILL PIPE ZONE

- A. Upper limit of pipe zone shall not be less than following: Pipe: 12 inches, unless shown otherwise.
- B. Restrain pipe as necessary to prevent their movement during backfill operations.
- C. Place material simultaneously in lifts on both sides of pipe and, if applicable, between pipes, conduit, cables, and duct banks installed in same trench.
  - 1. Maximum 6-inch lifts.
- D. Thoroughly tamp each lift, including area under haunches, with handheld tamping bars supplemented by “walking in” and slicing material under haunches with a shovel to ensure voids are completely filled before placing each succeeding lift.

### 3.06 MARKING TAPE INSTALLATION

- A. Continuously install marking tape along centerline of buried piping, on top of last lift of pipe zone material. Coordinate with piping installation drawings.

### 3.07 BACKFILL ABOVE PIPE ZONE

- A. General:
  - 1. Process excavated material to meet specified gradation requirements.
  - 2. Adjust moisture content as necessary to obtain specified compaction.

3. Do not allow backfill to free fall into trench or allow heavy, sharp pieces of material to be placed as backfill until after at least 2 feet of backfill has been provided over top of pipe.
4. Do not use power driven impact type compactors for compaction until at least 4 feet of backfill is placed over top of pipe.
5. Backfill to grade with proper allowances for topsoil, crushed rock surfacing, and pavement thicknesses, wherever applicable.
6. Backfill around structures with same class backfill as specified for adjacent trench, unless otherwise shown or specified.

B. Backfill Requirements: See Drawing details.

### 3.08 REPLACEMENT OF TOPSOIL

- A. Replace topsoil in top 12 inches of backfilled trench.
- B. Maintain finished grade of topsoil even with adjacent area and grade as necessary to restore drainage.

### 3.09 MAINTENANCE OF TRENCH BACKFILL

- A. After each section of trench is backfilled, maintain surface of backfilled trench even with adjacent ground surface until final surface restoration is completed.
- B. Gravel Surfacing Rock: Add gravel surfacing rock where applicable and as necessary to keep surface of backfilled trench even with adjacent ground surface, and grade and compact as necessary to keep surface of backfilled trenches smooth, free from ruts and potholes, and suitable for normal traffic flow.
- C. Topsoil: Add topsoil where applicable and as necessary to maintain surface of backfilled trench level with adjacent ground surface.
- D. Asphaltic Pavement: Replace settled areas or fill with asphalt as specified in Section 32 12 16, Asphalt Paving.
- E. Other Areas: Add excavated material where applicable and keep surface of backfilled trench level with adjacent ground surface.

### 3.10 SETTLEMENT OF BACKFILL

- A. Settlement of trench backfill, or of fill, or facilities constructed over trench backfill will be considered a result of defective compaction of trench backfill.

**END OF SECTION**

**SECTION 32 12 16**  
**ASPHALT PAVING**

**PART 1      GENERAL**

1.01      REFERENCES

A.      The following is a list of standards which may be referenced in this section:

1.      American Association of State Highway and Transportation Officials (AASHTO):
  - a.      M17, Standard Specification for Mineral Filler for Bituminous Paving Mixtures.
  - b.      M81, Standard Specification for Cut-Back Asphalt (Rapid Curing Type).
  - c.      M82, Standard Specification for Cut-Back Asphalt (Medium Curing Type).
  - d.      M140, Standard Specification for Emulsified Asphalt.
  - e.      M156, Standard Specification for Requirements for Mixing Plants for Hot-mixed, Hot-laid Bituminous Paving Mixes.
  - f.      M208, Standard Specification for Cationic Emulsified Asphalt.
  - g.      R35, Standard Practice for Superpave Volumetric Design for Hot Mix Asphalt.
  - h.      T166, Standard Method of Test for Bulk Specific Gravity (Gmb) of Compacted Hot Mix Asphalt (HMA) Mixtures Using Saturated Surface-Dry Specimens.
  - i.      T176 Standard Method of Test for Plastic Fines in Graded Aggregates and Soils by Use of the Sand Equivalent Test.
  - j.      T209, Standard Method of Test for Theoretical Maximum Specific Gravity (Gmm) and Density of Hot Mix Asphalt (HMA).
  - k.      T245, Standard Method of Test for Resistance to Plastic Flow of Asphalt Mixtures Using Marshall Apparatus.
  - l.      T246, Standard Method of Test for Resistance to Deformation and Cohesion of Hot Mix Asphalt (HMA) by Means of Hveem Apparatus.
  - m.      T247, Standard Method of Test for Preparation of Test Specimens of Hot Mix Asphalt (HMA) by Means of California Kneading Compactor.
  - n.      T283, Standard Method of Test for Resistance of Compacted Hot Mix Asphalt (HMA) to Moisture-Induced Damage.
  - o.      T304, Standard Method of Test for Uncompacted Void Content of Fine Aggregate.
  - p.      T312, Standard Method of Test for Preparing and Determining the Density of Hot Mix Asphalt (HMA) Specimens by Means of a Superpave Gyrotory Compactor.

2. Asphalt Institute (AI):
  - a. Manual Series No. 2 (MS-2), Mix Design Methods for Asphalt Concrete.
  - b. Superpave Series No. 2 (SP-2), Superpave Mix Design.
3. ASTM International (ASTM):
  - a. D75, Standard Method of Test for Sampling of Aggregates.
  - b. D140, Standard Method of Test for Sampling Bituminous Materials.
  - c. D979, Standard Method of Test for Sampling Bituminous Paving Mixtures.
  - d. D2041, Standard Test Method for Theoretical Maximum Specific Gravity and Density of Bituminous Paving Mixtures.
  - e. D2489, Standard Method of Test for Determining Degree of Particle Coating of Asphalt Mixtures.
  - f. D4318, Standard Test Methods for Liquid Limit, Plastic Limit, and Plasticity Index of Soils.
  - g. D4791, Standard Test Method for Flat Particles, Elongated Particles, or Flat and Elongated Particles in Coarse Aggregate.
  - h. D5821, Standard Test Method for Determining the Percentage of Fractured Particles in Coarse Aggregate.
  - i. E329 REV A, Standard Specification for Agencies Engaged in Construction Inspection Testing, or Special Inspection.

## 1.02 DEFINITIONS

- A. Combined Aggregate: All mineral constituents of asphalt concrete mix, including mineral filler and separately sized aggregates.
- B. Reclaimed asphalt pavement (RAP): Removed and/or processed pavement materials containing binder and aggregate.
- C. Standard Specifications: Florida Department of Transportation Standard Specifications for Road and Bridge Construction, latest edition.

## 1.03 DESIGN REQUIREMENTS

- A. Prepare asphalt concrete mix design, meeting the following design criteria, tolerances, and other requirements of this Specification.

## 1.04 SUBMITTALS

- A. Informational Submittals:
  1. Asphalt Concrete Mix Formula:
    - a. Submit minimum of 15 days prior to start of production.
    - b. Submittal to include the following information: Properties as stated in Section 334 of the Standard Specifications.



2. Manufacturer's Certificate of Compliance, in accordance with Section 01 61 00, Common Product Requirements, for the following materials:
  - a. Aggregate: Gradation, source test results as defined in Section 334 of the Standard Specifications.
  - b. Asphalt for Binder: Type, grade, and viscosity-temperature curve.
  - c. Prime Coat: Type and grade of asphalt.
  - d. Tack Coat: Type and grade of asphalt.
  - e. Additives.
  - f. Mix: Conforms to job-mix formula.
3. Statement of qualification for independent testing laboratory.
4. Test Results:
  - a. Mix design.
  - b. Asphalt concrete core.
  - c. Gradation and asphalt content of uncompacted mix.

#### 1.05 QUALITY ASSURANCE

##### A. Qualifications:

1. Independent Testing Laboratory: In accordance with ASTM E329.
2. Asphalt concrete mix formula shall be prepared by approved certified independent laboratory under the supervision of a certified asphalt technician.

#### 1.06 ENVIRONMENTAL REQUIREMENTS

- ##### A. Moisture: Do not apply asphalt materials or place asphalt mixes when application surface is wet.

### **PART 2 PRODUCTS**

#### 2.01 MATERIALS

- ##### A. Prime Coat: Cutback asphalt, conform to Section 300 of the Standard Specifications.
- ##### B. Tack Coat: Emulsified Asphalt for Tack Coat or Seal Coat: conform to Section 300 of the Standard Specifications.

#### 2.02 ASPHALT CONCRETE MIX

##### A. General:

1. Mix formula shall not be modified except with written approval of Engineer.
2. Source Changes:
  - a. Should material source(s) change, establish new asphalt concrete mix formula before new material(s) is used.

- b. Perform check tests of properties of plant-mix bituminous materials on first day of production and as requested by Engineer to confirm that properties are in compliance with design criteria.
  - c. Make adjustments in gradation or asphalt content as necessary to meet design criteria.
- B. Asphalt Concrete: as specified in Section 334 of the Standard Specifications.
- C. Composition: Hot-plant mix of aggregate, mineral filler if required, and paving grade asphalt cement. The several aggregate fractions shall be sized, uniformly graded, and combined in such proportions that resulting mixture meets grading requirements of mix formula.
- D. Aggregate:
  - 1. General: As specified in Section 334 of the Standard Specifications, Superpave Asphalt Concrete.
- E. Mineral Filler: In accordance with Section 334 of the Standard Specifications.
- F. Asphalt Cement: Paving Grade to match existing grade.

**PART 3 EXECUTION**

3.01 GENERAL

- A. Traffic Control:
  - 1. In accordance with Section 01 50 00, Temporary Facilities and Controls.
  - 2. Minimize inconvenience to traffic, but keep vehicles off freshly treated or paved surfaces to avoid pickup and tracking of asphalt.
- B. Driveways: Repave driveways from which pavement was removed. Leave driveways in as good or better condition than before start of construction.

3.02 LINE AND GRADE

- A. Provide and maintain intermediate control of line and grade, independent of underlying base, to meet finish surface grades and minimum thickness.
- B. Shoulders: Construct to line, grade, and cross-section shown.

3.03 APPLICATION EQUIPMENT

- A. In accordance with Section 334 of the Standard Specifications.

### 3.04 PREPARATION

- A. Prepare subgrade as specified in Standard Specifications
- B. Existing Roadway:
  - 1. Modify profile by grinding, milling, or overlay methods as approved, to provide meet lines and surfaces and to produce smooth riding connection to existing facility.
  - 2. Remove existing material to a minimum depth of 1 inch (25 millimeters).
  - 3. Paint edges of meet line with tack coat prior to placing new pavement.
- C. Thoroughly coat edges of contact surfaces (curbs, manhole frames) with emulsified asphalt or asphalt cement prior to laying new pavement. Prevent staining of adjacent surfaces.

### 3.05 PAVEMENT APPLICATION

- A. General: Place asphalt concrete mixture on approved, prepared base in conformance with the Standard Specifications.
- B. Prime Coat:
  - 1. Heat cutback asphalt, as specified in Section 300 of the Standard Specifications, prior to application.
  - 2. Apply uniformly to clean, dry surfaces avoiding overlapping of applications.
  - 3. Do not apply when moisture content of upper 3 inches (75 millimeters) of base exceeds optimum moisture content of base, or if free moisture is present.
  - 4. Remove or redistribute excess material.
  - 5. Allow a minimum of 5 full days for curing of primed surface before placing asphalt concrete.
- C. Tack Coat:
  - 1. Prepare material, as specified in Section 300 of the Standard Specifications, prior to application.
  - 2. Apply uniformly to clean, dry surfaces avoiding overlapping of applications.
  - 3. Do not apply more tack coat than necessary for the day's paving operation.
  - 4. Touchup missed or lightly coated surfaces and remove excess material.

D. Pavement Mix:

1. Prior to Paving:
  - a. Sweep primed surface free of dirt, dust, or other foreign matter.
  - b. Patch holes in primed surface with asphalt concrete pavement mix.
  - c. Blot excess prime material with sand.
2. Place asphalt concrete pavement mix to match existing.
3. Total Compacted Thickness: As shown on Drawings.
4. Sequence placement so that meet lines are straight and edges are vertical.
5. Collect and dispose of segregated aggregate from raking process. Do not scatter material over finished surface.
6. Joints:
  - a. Offset edge of each layer a minimum of 6 inches (150 millimeters) so joints are not directly over those in underlying layer.
  - b. Offset longitudinal joints in roadway pavements so longitudinal joints in wearing layer coincide with pavement centerlines and lane divider lines.
  - c. Form transverse joints by cutting back on previous day's run to expose full vertical depth of layer.
7. Succeeding Lifts: Apply tack coat to pavement surface between each lift.
8. After placement of pavement, seal meet line by painting a minimum of 6 inches (150 millimeters) on each side of joint with cutback or emulsified asphalt. Cover immediately with sand.

E. Compaction: In accordance with the Standard Specifications

F. Tolerances: In accordance with the Standard Specifications.

3.06 PATCHING

A. Preparation:

1. Remove damaged, broken, or unsound asphalt concrete adjacent to patches. Trim to straight lines exposing smooth, sound, vertical edges.
2. Prepare patch subgrade as specified in the Standard Specifications.

B. Application:

1. Patch Thickness: 3 inches (75 millimeters) or thickness of adjacent asphalt concrete, whichever is greater.
2. Place asphalt concrete mix across full width of patch in layers of equal thickness.
3. Spread and grade asphalt concrete with hand tools or mechanical spreader, depending on size of area to be patched.

## C. Tolerances:

1. Finished surface shall be flush with and match grade, slope, and crown of adjacent surface.
2. Tolerance: Surface smoothness shall not deviate more than plus 1/4 inch (6 millimeters) or minus 0 inch when straightedge is laid across patched area between edges of new pavement and surface of old surfacing.

## 3.07 SCOPE OF WORK

- A. Repave all paved areas demolished or disturbed during construction.

## 3.08 FIELD QUALITY CONTROL

- A. General: Provide services of approved certified independent testing laboratory to conduct tests.

## B. Field Density Tests:

1. Perform tests from cores or sawed samples in accordance with AASHTO T166.
2. Measure with properly operating and calibrated nuclear density gauge in accordance with ASTM D2950.
3. Maximum Density: In accordance with ASTM D204, using sample of mix taken prior to compaction from same location as density test sample.

## C. Testing Frequency:

1. Quality Control Tests:
  - a. Asphalt Content, Aggregate Gradation: Once per every 500 tons (400 mg) of mix or once every 4 hours, whichever is greater.
  - b. Mix Design Properties, Measured Maximum (Rice's) Specific Gravity: Once every 1,000 tons (900 mg) or once every 8 hours, whichever is greater.
2. Density Tests: Once every 500 tons (450 mg) of mix or once every 4 hours, whichever is greater.

**END OF SECTION**



**SECTION 33 05 01.02**  
**DUCTILE IRON PIPE AND FITTINGS**

**PART 1 GENERAL**

1.01 REFERENCES

- A. The following is a list of standards that may be referenced in this section:
1. American Association of State Highway and Transportation Officials (AASHTO): T99, Standard Method of Test for the Moisture-Density Relations of Soils Using a 2.5-kg (5.5-lb) Rammer and a 305-mm (12-in.) Drop.
  2. American Society of Mechanical Engineers (ASME):
    - a. B16.21, Nonmetallic Flat Gaskets for Pipe Flanges.
    - b. B16.42, Ductile Iron Pipe Flanges and Flanged Fittings Classes 150 and 300.
  3. American Water Works Association (AWWA):
    - a. C104/A21.4, Cement-Mortar Lining for Ductile-Iron Pipe and Fittings.
    - b. C105/A21.5, Polyethylene Encasement for Ductile-Iron Pipe Systems.
    - c. C110/A21.10, Ductile-Iron and Gray-Iron Fittings.
    - d. C111/A21.11, Rubber-Gasket Joints for Ductile-Iron Pressure Pipe and Fittings.
    - e. C115/A21.15, Flanged Ductile-Iron Pipe with Ductile-Iron or Gray-Iron Fittings.
    - f. C116/A21.16, Protective Fusion-Bonded Epoxy Coatings for the Interior and Exterior Surfaces of Ductile-Iron and Gray-Iron Fittings for Water Supply Service.
    - g. C150/A21.50, Thickness Design of Ductile-Iron Pipe.
    - h. C151/A21.51, Ductile-Iron Pipe. Centrifugally Cast, for Water.
    - i. C153/A21.53, Ductile-Iron Compact Fittings for Water Service.
    - j. C600, Installation of Ductile-Iron Water Mains and Their Appurtenances.
    - k. C606, Grooved and Shouldered Joints.
  4. ASTM International (ASTM):
    - a. A307, Standard Specification for Carbon Steel Bolts and Studs, 60,000 psi Tensile Strength.
    - b. A563, Standard Specification for Carbons and Alloy Steel Nuts.
    - c. D882, Standard Test Method for Tensile Properties of Thin Plastic Sheeting.
    - d. D1330, Standard Specification for Rubber Sheet Gaskets.
    - e. D1922, Standard Test Method for Propagation Tear Resistance of Plastic Film and Thin Sheeting by Pendulum Method.

- f. D2000, Standard Classification System for Rubber Products in Automotive Applications.
  - g. D4976, Standard Specification for Polyethylene Plastics Molding and Extrusion Materials.
5. International Organization for Standardization (ISO): 9001, Quality Management Systems – Requirements.

## 1.02 SUBMITTALS

### A. Action Submittals:

- 1. Shop Drawings: Marking plan and details of standard pipe section showing dimensions, pipe joints, fitting and special fitting pressure rating and thickness, size, coating and lining data.

### B. Informational Submittals:

- 1. Manufacturer shall furnish sworn certificates that pipe and fittings have been manufactured, tested, and inspected in accordance with this and all applicable Specifications.
- 2. Field Hydrostatic Testing Plan: Submit at least 15 days prior to testing and at minimum, include the following:
  - a. Testing dates.
  - b. Piping systems and section(s) to be tested.
  - c. Method of isolation.
  - d. Method of conveying water from source to system being tested.
  - e. Calculation of maximum allowable leakage for piping section(s) to be tested.

## 1.03 QUALITY ASSURANCE

- A. Pipe manufacturer shall be ISO 9001 registered or provide the services of an independent inspection agency.
- B. Prior to start of manufacturing, manufacturer not meeting or having ISO registration requirements shall submit name of at least two independent inspection agencies for approval.
  - 1. Independent inspection agency shall be responsible, on a daily basis, for sample monitoring of chemical and mechanical tests, sample visual inspection of quality assurance tests performed on in-process pipe and fittings, and sample visual and dimensional inspection on finished products.



**PART 2 PRODUCTS****2.01 MATERIALS****A. General:**

1. Ductile iron pipe shall be manufactured, lined, coated, and tested domestically in the United States of America.
2. Pipe manufacturer shall certify source manufacturing facility has been producing ductile iron pipe of the specified diameters, pressure, dimensions and standards for a period of not less than 10 years.

**B. Pipe:**

1. General:
  - a. Pipe shall be new and recently manufactured. Refurbished pipe shall not be provided.
  - b. Lined and coated as specified.
2. Meet requirements of AWWA C150/A21.50, AWWA C151/A21.51, and AWWA C111/A21.11.
3. Centrifugally cast, grade 60-42-10 iron.
4. Pressure rating of pipe shall be 250 psi.

**C. Joints:**

1. Restrained Joint:
  - a. Manufactured proprietary joint that mechanically restrains pipe to adjoining pipe.
  - b. Manufacturers and Products:
    - 1) American Cast Iron Pipe; Flex-Ring, Field Flex-Ring, and Lok-Ring.
    - 2) Pacific States Pipe; Thrust-Lock.
    - 3) U.S. Pipe; TR Flex and HP Lok.
2. Mechanical Wedge Action Type Joint:
  - a. Use only in areas where adjoining to fixed points where laying length is determined in field.
  - b. Prior to purchase and installation, type and application of this joint shall be approved by Engineer.
3. Use of set screws for restraint or field-lock gaskets shall not be allowed.

**D. Fittings:**

1. Fittings shall be new and recently manufactured. Refurbished fittings will not be accepted.
2. Restrained Joint: 250 psi pressure class.

3. Rubber Gasket Joints Including Mechanical Joints, Push-On Joints, and Flanged Joints: In accordance with AWWA C111/A21.11 [or ASME B16.42].
4. Mechanical Joint Fittings: In accordance with AWWA C110/A21.10 and AWWA C153/A21.53.

E. Lining:

1. Pipe and fittings for clean water applications shall be cement-lined and asphaltic seal coated in accordance with AWWA C104/A21.4.

F. Coating:

1. Basecoat: Zinc
2. Topcoat: Asphaltic type, 1 mil thick, in accordance with AWWA C151/A21.51, AWWA C115/A21.15, AWWA C110/A21.10, and AWWA C153/A21.53.

G. Polyethylene Encasement:

1. Virgin polyethylene raw material conforming to requirements of ASTM D4976.
2. Elongation: 800 percent, minimum, in machine and transverse direction (ASTM D882).
3. Tensile Strength: 3,600 psi, minimum.
4. Dielectric Strength: 800V per mil-thickness, minimum.
5. Propagation Tear Resistance: 2,550-gram force (gf), minimum, in machine and transverse direction (ASTM D1922).
6. Tube Form: Conform to AWWA C105/A21.5.
7. Film: 0.008 inch (8 mil) thick, minimum.
8. Number of Film Layers: [One.] [Two.]

H. Bolting:

1. Flanged Connection Bolts: Carbon steel, ASTM A307, Grade A hex bolts and ASTM A563, Grade A hex head nuts.
2. Grooved End Connections Bolts: Manufacturer's standard.

2.02 SOURCE QUALITY CONTROL

- A. In accordance with AWWA C110/A21.10.

**PART 3 EXECUTION**

## 3.01 EXAMINATION

- A. Inspect pipe and fittings to ensure no cracked, broken, or otherwise defective materials are being used.

## 3.02 PREPARATION

- A. Trench Grade:
  - 1. When specified, grade bottom of trench by hand to specified line and grade with proper allowance for pipe thickness and pipe base. Trench bottom shall form a continuous and uniform bearing and support for pipe between bell holes.
  - 2. Before laying each section of pipe, check grade and correct irregularities found. Grade may be disturbed for removal of lifting tackle.
- B. Pipe Bedding: In accordance with Section 31 23 23.
- C. Bell (Joint) Holes: At each joint, dig bell holes of ample dimensions in bottom of trench, and at sides where necessary, to permit joint to be made properly and to permit easy visual inspection of entire joint.

## 3.03 INSTALLATION

- A. General:
  - 1. Provide and use proper implements, tools, and facilities for safe and proper prosecution of the Work.
  - 2. Lower pipe, fittings, and appurtenances into trench, piece by piece, by means of a crane, slings, or other suitable tools and equipment, in such a manner as to prevent damage to pipe materials, protective coatings and linings.
  - 3. Do not drop or dump pipe materials into trench.
- B. Cleaning Pipe and Fittings:
  - 1. Remove lumps, blisters, and excess coal tar coating from bell and spigot ends of each pipe. Wire brush outside of spigot and inside of bell and wipe clean, dry, and free from oil and grease before pipe is laid.
  - 2. Wipe ends of mechanical joint pipe and fittings and of rubber gasket joint pipe and fittings clean of dirt, grease, and foreign matter.

C. Laying Pipe:

1. Direction of Laying: Lay pipe with bell end facing in direction of laying. For lines on an appreciable slope, face bells upgrade at discretion of Engineer.
2. Mechanical Joint, Push-On Joint, and Restrained Joint Pipe: After first length of pipe is installed in trench, secure pipe in place with approved backfill material tamped under and along sides to prevent movement. Keep ends clear of backfill. After each section is jointed, place backfill as specified to prevent movement.
3. Take precautions necessary to prevent floating of pipe prior to completion of backfill operation.
4. When using movable trench shield, take necessary precautions to prevent pipe joints from pulling apart when moving shield ahead.
5. Do not allow foreign material to enter pipe while it is being placed in trench.
6. Close and block open end of last laid section of pipe to prevent entry of foreign material or creep of gasketed joints when laying operations are not in progress, at close of day's work, or whenever workers are absent from job.

D. Joining Push-On Joint Pipe and Mechanical Joint Fittings:

1. Join pipe with push-on joints and mechanical joint fittings in accordance with manufacturer's recommendations.
2. Provide special tools and devices, such as, special jacks, chokers, and similar items required for installation.
3. Lubricate pipe gaskets using lubricant furnished by pipe manufacturer. No substitutes will be permitted.
4. Clean ends of fittings of dirt, mud, and foreign matter by washing with water and scrubbing with a wire brush, after which, slip gland and gasket on plain end of pipe. If necessary, lubricate end of pipe to facilitate sliding gasket in place, then guide fitting onto spigot of pipe previously laid.

E. Cutting Pipe:

1. General: Cut pipe for inserting valves, fittings, or closure pieces in a neat and workmanlike manner without damaging pipe or lining and so as to leave a smooth end, at right angles to axis of pipe.
2. Pipe: Cut pipe with milling type cutter or saw. Do not flame cut.
3. Dressing Cut Ends: Dress cut end of mechanical joint pipe to remove sharp edges or projections, which may damage rubber gasket. Dress cut ends of push-on joint pipe by beveling, as recommended by manufacturer.

## F. Field Welding:

1. Use of field welded outlets will not be allowed. Welding for outlets shall be performed only in pipe manufacturer's shop.
2. Field installed outlets may be installed with saddle approved by Engineer. Opening in pipe shall be machined cut and not with cutting torch.
3. Field welding of bars for restrained joint systems will not be allowed. Welding shall be performed in pipe manufacturer's shop.

## G. Line and Grade:

1. Minimum Pipe Cover: 3 feet, unless otherwise indicated.
2. No high points will be allowed between air valves.
3. Maintain pipe grade between invert elevations to provide minimum clearance at air valve locations of 4 feet from existing ground surface to top of pipe.
4. Install air valves as shown and field verify intervening low points. When field conditions warrant, exceptions may be made upon approval of Engineer.
5. Deviations exceeding 6 inches from specified line or 1 inch from specified grade will not be allowed without express approval of Engineer.
6. Pipeline sections that are not installed to elevations shown or installed as approved by Engineer shall be reinstalled to proper elevation.

## H. Thrust Restraint:

1. Primary method of restraint shall be through use of restrained joint pipe. Thrust blocking shall be used where detailed on Drawings and as approved by Engineer.

## I. Backfill for Pipe Zone: In accordance with Section 31 23 23.

## J. Polyethylene Encasement:

1. Encase pipe, fittings, and valves where specified in accordance with AWWA C105/A21.5, Method A.
2. Cut polyethylene tube approximately 2 feet longer than pipe length.
3. Slip tube around pipe, centering to provide 1-foot overlap on each adjacent section.
4. Pull encasement to take out slack and wrap snug around pipe.
5. Secure overlap in place and fold at quarter points of pipe length.
6. Wrap and tape encasement snug around fittings and valves.
7. Encasement within sections of pipe installed in steel casings is not required.

3.04 HYDROSTATIC TESTING

A. Pipeline Hydrostatic Test:

1. General:
  - a. Notify Engineer in writing 5 days in advance of testing. Perform testing in presence of Engineer.
  - b. Test newly installed pipelines. Using water as test medium, pipes shall successfully pass a leakage test prior to acceptance.
  - c. Furnish testing equipment and perform tests in manner satisfactory to Engineer. Testing equipment shall provide observable and accurate measurements of leakage under specified conditions.
  - d. Isolate new pipelines that are connected to existing pipelines.
  - e. Conduct tests on entire pipeline after trench has been backfilled. Testing may be done prior to placement of asphaltic concrete or roadway structural section.
  - f. Contractor may, if field conditions permit and as determined by Engineer, partially backfill trench and leave joints open for inspection and conduct an initial service leak test. Hydrostatic test shall not, however, be conducted until backfilling has been completed.
  - g. Supply of temporary water shall be as stated in Section 01 50 00, Temporary Facilities and Controls.
  - h. Dispose of water used in testing.
2. Procedure:
  - a. Maximum filling velocity shall not exceed 0.25 foot per second, calculated based on the full area of pipe.
  - b. Expel air from pipe system during filling. Expel air through air release valve or through corporation stop installed at high points and other strategic points.
  - c. Test pressure shall be 150 psi.
  - d. Apply and maintain specified test pressure with hydraulic force pump. Valve off piping system when test pressure is reached.
  - e. Maintain hydrostatic test pressure continuously for 2 hours minimum.
  - f. If measured leakage exceeds allowable leakage or if leaks are visible, repair defective pipe section and repeat hydrostatic test.
3. Allowable Leakage: Allowable leakage is zero.

**END OF SECTION**

**SECTION 33 05 01.10**  
**HIGH-DENSITY POLYETHYLENE (HDPE) PRESSURE PIPE AND FITTINGS**

**PART 1 GENERAL**

1.01 REFERENCES

- A. The following is a list of standards that may be referenced in this section:
1. American Society of Mechanical Engineers (ASME):
    - a. Boiler and Pressure Vessel Code, Section IX, Article XXI-XXIV.
    - b. B16.1, Gray Iron Pipe Flanges and Flanged Fittings: Classes 25, 125, and 250.
    - c. B18.2.1, Square, Hex, Heavy Hex, and Askew Head Bolts and Hex, Heavy Hex, Hex Flange, Lobed Head, and Lag Screws (Inch Series).
    - d. B18.2.2, Nuts for General Applications: Machine Screw Nuts, Hex, Square, Hex Flange, and Coupling Nuts (Inch Series).
  2. American Water Works Association (AWWA):
    - a. C906, Polyethylene (PE) Pressure Piping and Fittings, 4 in. through 65 in. for Waterworks.
    - b. Manual M55, PE Pipe - Design and Installation.
  3. ASTM International (ASTM):
    - a. A193/A193M, Standard Specification for Alloy-Steel and Stainless Steel Bolting Materials for High Temperature or High Pressure Service and Other Special Purpose Applications.
    - b. A194/A194M, Standard Specification for Carbon Steel, Alloy Steel, and Stainless Steel Nuts for Bolts for High Pressure or High Temperature Service, or Both.
    - c. A240/A240M, Standard Specification for Chromium and Chromium-Nickel Stainless Steel Plate, Sheet, and Strip for Pressure Vessels and for General Applications.
    - d. A307, Standard Specification for Carbon Steel Bolts, Studs, and Threaded Rod 60,000 psi Tensile Strength.
    - e. A536, Standard Specification for Ductile Iron Castings.
    - f. A563, Standard Specification for Carbon and Alloy Steel Nuts.
    - g. D3035, Standard Specification for Polyethylene (PE) Plastic Pipe (DR-PR) Based on Controlled Outside Diameter.
    - h. D3261, Standard Specification for Butt Heat Fusion Polyethylene (PE) Plastic Fittings for Polyethylene (PE) Plastic Pipe and Tubing.
    - i. D3350, Standard Specification for Polyethylene Plastics Pipe and Fittings Materials.
    - j. F714, Standard Specification for Polyethylene (PE) Plastic Pipe (DR-PR) Based on Outside Diameter.

- k. F2164, Standard Practice for Field Leak Testing of Polyethylene (PE) and Crosslinked Polyethylene (PEX) Pressure Piping Systems Using Hydrostatic Pressure.
- l. F2620, Standard Practice for Heat Fusion Joining of Polyethylene Pipe and Fittings.
4. Code of Federal Regulations (CFR): Title 49 Part 192.285, Plastic Pipe: Qualifying Persons to Make Joints.
5. NSF International (NSF): 61, Drinking Water System Components - Health Effects.
6. Plastics Pipe Institute (PPI):
  - a. Handbook of PE Pipe.
  - b. Technical Note 38, Bolt Torque for Polyethylene Flanged Joints.
  - c. TR-33, Generic Butt Fusion Joining Procedure for Field Joining of Polyethylene Pipe.

## 1.02 SUBMITTALS

### A. Action Submittals:

1. Shop Drawings:
  - a. Catalog information confirming pipe, fittings, and other materials conform to requirements of this section.
  - b. Drawings of specific connection details.

### B. Informational Submittals:

1. Manufacturer's Certificate of Compliance, in accordance with Section 01 61 00, Common Product Requirements.
2. Infrared temperature gun product data.
3. Experience, training record, and certificates of persons to be fusing HDPE pipe.
4. Information on manufacturer and model of machine to be used for fusion of HDPE pipe.
5. Testing Plan: Submit at least 15 days prior to testing and include the following as a minimum:
  - a. Testing dates.
  - b. Piping systems and section(s) to be tested.
  - c. Method of isolation.
  - d. Method of conveying water from source to system being tested.
6. Certifications of Calibration: Approved testing laboratory certificate if pressure gauge for hydrostatic test has been previously used. If pressure gauge is new, no certificate is required.
7. Test report documentation.



### 1.03 QUALITY ASSURANCE

#### A. Qualifications:

1. Pipe Manufacturer: Listed with Plastic Pipe Institute.
2. Experienced in fabricating pipe of similar diameters and wall thickness required for the Work.
3. Persons fusing HDPE pipe shall have a current operator qualification training certificate and have a minimum of 5 years' experience.

### 1.04 DELIVERY, STORAGE, AND HANDLING

#### A. Shipping: Do not cut, kink, or otherwise damage pipe during transportation.

#### B. Storage and Handling:

1. Pipe interiors are to be inspected and all debris removed prior to storage.
2. Limit stacking of pipe to a height that will not cause excessive deformation of bottom layers of pipes under anticipated temperature conditions.
3. Do not exceed the stacking heights stated in AWWA Manual M55.
4. Where necessary, because of ground conditions, store pipe on wooden sleepers, spaced suitably and of such widths as not to allow deformation of pipe at point of contact with sleeper or between supports.
5. Comply with the requirements of the approved Installation Plan.
6. Keep pipe shaded from direct sunlight prior to fusion and installation in trench.

### 1.05 CONNECTIONS TO EXISTING PIPE

- A. Fusing to Existing Pipe: Comply with manufacturer's or distributor's recommendations based on Site conditions and PPI TR-33.

## **PART 2 PRODUCTS**

### 2.01 MATERIALS

#### A. Pipe and Fittings:

1. Conform to requirements of AWWA C906.
2. In compliance with NSF 61.
3. Resin:
  - a. Potable Water Transmission and Distribution Systems: Polyethylene resin shall meet or exceed requirements of ASTM D3350 for PE 4710 material with cell classification of 445474C, or better. PE 4710 HDPE pipe and fittings shall be manufactured from bimodal resins. Pressure rating shall be based on hydrostatic design stress of 1,000 psi at 73.4 degrees F.

4. Pressure Rating: 200 psi and nominal DR of 11.
  5. Outside Diameter Basis: DIPS.
  6. Pipe lengths, fittings, and flanged connections to be joined by thermal butt-fusion shall be of a compatible resin mix for the fusion process.
  7. Fittings:
    - a. Polyethylene fittings shall have same or higher pressure rating as pipe.
    - b. Sizes Larger than 12 Inches: Thermal butt-fused fabricated.
    - c. Unless noted otherwise, provide fittings with a factory fused 4-foot-long spool on each end to facilitate onsite fusion.
- B. Backup Rings:
1. Convolved for Flanged Connections:
    - a. ASTM A536, ductile iron.
    - b. Complete with one-piece, molded polyethylene flange adapters.
    - c. Flanged Connections: Same or greater pressure rating as pipe.
  2. Ductile Iron: In accordance with Section 33 05 01.01 Ductile Iron Pipe and Fittings
  3. Gaskets: Material, size, and thickness shall be as recommended by gasket manufacturer and in accordance with PPI Technical Note 38. Gasket manufacturer shall provide a table with recommended bolt torque and tightening pattern.
- C. Joints: Thermal butt-fusion or electrofusion except where connecting to unions, valves, and equipment with flanged or threaded connections that may require future disassembly. Use appropriate transition fitting or adapter for all joints that are not thermal butt-fused or electro-fused.
- D. Bolts, Nuts, and Washers:
1. Bolt Materials: Type 316 stainless steel, ASTM A193/A193M, Grade B8M hex-head, carbide solution treated and strained hardened.
  2. Bolt Fabrication: In accordance with ASME B18.2.1
  3. Nut Materials: Type 316 stainless steel, ASTM A194/A194M, Grade 8 hex-head.
  4. Nut Fabrication: In accordance with ASME B18.2.2.
  5. Washers: Type 316 stainless steel. Same material as bolts in accordance with ASME B18.21.1.
  6. Thread Lubricant: Provide bolt manufacturer's recommended lubricant on bolt threads, nuts, nut face, and around bolt hole.
  7. Corrosion Resistance: When used in submerged brine water applications, bolts, nuts, and washers shall be coated in polytetrafluoroethylene (PTFE) applied by fastener manufacturer.

- E. Electrofusion Flex Restraint:
  - 1. Material: HDPE.
  - 2. Method of Attachment: Electrofusion.
  - 3. Designed for restraining movement of HDPE pipe.
  - 4. Manufacturers:
    - a. Central Plastics Company.
    - b. Industrial Pipe Fittings, IPF-Plasson.
  
- F. Electrofusion Couplings:
  - 1. Material: HDPE.
  - 2. Method of Attachment: Electrofusion.
  - 3. Designed for coupling HDPE pipe.
  - 4. Manufacturers:
    - a. Central Plastics Company.
    - b. ISCO Industries.
  
- G. Transitional Fitting:
  - 1. HDPE x DI MJ adapter.
  - 2. Designed for connecting HDPE pipe to ductile iron fittings.
  - 3. Manufacturers:
    - a. Central Plastics Company.
    - b. ISCO Industries.
  
- H. Concrete Thrust Blocks: See Drawings.
  
- I. Products that restrain HDPE pipe with wedges or clamps are not acceptable.

## **PART 3 EXECUTION**

### **3.01 INSTALLATION**

- A. General:
  - 1. Install polyethylene pipe in conformance with AWWA M55, PPI TR-33, ASTM F2620, and pipe manufacturer's recommendations.
  
- B. Joining: Butt-fuse pipes and fittings in accordance with pipe manufacturer's recommendations. Depending on Site conditions, perform butt-fusion joining in or outside of excavated trench.
  - 1. If HDPE pipe surface temperature is above degrees F as measured with infrared temperature gun, allow pipe to cool prior to making any connections to flanges, existing pipeline systems, or structures.

2. Connect HDPE pipe to auxiliary equipment such as valves, pumps, tanks, and other piping systems with flanged connections as follows:
  - a. Polyethylene flange adapter, thermally butt-fused to end of pipe. Flange “stub ends” are not allowed.
  - b. Bolt and nut of sufficient length to show a minimum of three complete threads when joint is made and tightened to manufacturer’s standard.
  - c. Follow requirements of PPI Technical Note 38 including mandatory 4-hour bolt re-torquing.
3. Special Precautions at Flanges: Support polyethylene pipe connected to heavy fittings, manholes, and rigid structures in such a manner that no subsequent relative movement between polyethylene pipe at flanged joint and rigid structures is possible.
4. Minimum Long-Term Field Bending Radius: Restricted to limits recommended by AWWA M55, Table 8-2.

C. Placement in Trench:

1. Handle joined pipeline in such a manner that pipe is not damaged by dragging it over sharp and cutting objects.
2. Position slings for handling pipeline away from butt-fused joints.
3. Remove sections of damaged pipe and replace it with undamaged pipe. Damaged pipe is defined as pipe with kinks or gouges exceeding 10 percent of pipe wall thickness.
4. Exercise care when lowering pipe into trench to prevent damage or twisting of pipe.
5. At flanges, valves, and connections, excavate out trench bottom sufficiently to ensure clearance between undisturbed trench bottom and flange, valve, or connection.

3.02 FIELD QUALITY CONTROL

A. Joint Butt Fusion:

1. Measure and log each joint fusion by an electronic monitoring device (data logger) affixed to fusion machine. Data to be logged shall include the following and shall be capable of being retrieved electronically:
  - a. Pipe size, dimensions, and wall thickness.
  - b. Machine model and size.
  - c. Operator identification.
  - d. Job identification number.
  - e. Weld number.
  - f. Fusion, heating, and drag pressure settings.
  - g. Heater plate temperature.
  - h. Time stamp showing when weld was performed.
  - i. Heating and curing time of weld.

- j. Curing temperature readings and time stamps of readings.
  - k. Error messages and warnings for out of range temperature or pressure settings.
2. In addition to logged items above, the following shall be logged or annotated on report:
- a. Location of joint being fused by pipeline station or by reference to pipe Shop Drawing.
  - b. Ambient temperature, wind speed, precipitation, and humidity.
  - c. If internal bead was removed.
  - d. Environmental actions taken (such as, use of tarps, enclosures, and blankets).
  - e. Type of HDPE and manufacturer.

**B. Joint Weld Inspection:**

- 1. Visually examine each joint in accordance with the guidelines in ASTM F2620. Remove and replace any joints not meeting the standard.
- 2. Mechanical Joint Testing:
  - a. Pipe Wall Thickness 1-Inch or Less: Test joints in accordance with bend back testing provided in Appendix X4 of ASTM F2620.
  - b. Pipe Wall Thickness Greater than 1-Inch: Test joints in accordance with the guided side bend testing in accordance with ASME BPVC, Section IX, Article XXI-XXIV.
  - c. Specimens: Cut pipe 12 inches on each side of field made joint. Rejoin ends and proceed with Work.
  - d. Test Frequency:
    - 1) First 1,000 Linear Feet: Two joints selected at random by Engineer.
    - 2) Each Test Failure: Two additional joints selected at random by Engineer.

**C. Pipeline Hydrostatic Test:**

- 1. General:
  - a. Notify Engineer in writing 5 days in advance of testing. Perform testing in presence of Engineer.
  - b. Furnish testing equipment and perform tests in manner satisfactory to Engineer. Testing equipment shall provide observable and accurate measurements of initial service leak and allowable make-up water volume under specified conditions.
  - c. Test newly installed pipelines.
  - d. Isolate new pipelines that are connected to existing pipelines.
  - e. Using water as test medium, pipes shall successfully pass a hydrostatic test prior to acceptance.

- f. Conduct field hydrostatic test on buried piping after trench has been completely backfilled. Testing may, as approved by Engineer, be done prior to placement of asphaltic concrete or roadway structural section.
  - g. Contractor may, if field conditions permit and as determined by Engineer, partially backfill trench and leave joints open for inspection and conduct initial service leak test. Final field hydrostatic test shall not be conducted until backfilling has been completed as specified above.
  - h. Supply of temporary water shall be as stated in Section 01 50 00, Temporary Facilities and Controls.
  - i. Dispose of water used in testing in accordance with federal, state, and local requirements.
2. Preparation:
- a. Install thrust blocking as shown on drawings prior to pressure testing to prevent movement of pipe and protect adjacent piping or equipment. Make necessary taps in piping prior to testing.
  - b. Wait 5 days minimum after concrete thrust blocking or designed thrust collars are installed to perform pressure tests.
  - c. Prior to test, remove or suitably isolate appurtenant instruments or devices that could be damaged by pressure testing.
  - d. New Piping Connected to Existing Piping: Isolate new piping with grooved-end pipe caps, blind flanges, or other means as acceptable to Engineer.
3. Procedure:
- a. Test pressure shall be 125 psi as measured at lowest point in pipeline.
  - b. Maximum filling velocity shall not exceed 0.25 feet per second, calculated based on full area of the pipe.
  - c. Expel air from pipe system during filling.
  - d. Test procedure shall be in accordance with ASTM F2164.
    - 1) Initial Expansion Phase: Add water as required to maintain test pressure for 4 hours.
    - 2) Test Phase: Reduce pressure by 10 psi and start pressure test.
    - 3) Test is successful if pressure stays within 5 percent of initial value for 1 hour.
  - e. If test is not completed because of leakage, equipment failure, or other reasons, depressurize test section and allow it to relax for at least 8 hours before retesting.
  - f. If there is leakage, repair defective pipe section and repeat hydrostatic test.

3.03 DISINFECTION

- A. Conform to the requirements of Section 33 13 00, Disinfection of Water Utility Distribution Facilities.
- B. Active chlorine concentration shall not exceed 10 percent.

3.04 MANUFACTURER'S SERVICES

- A. Provide pipe manufacturer's representative at Site for assistance during pipe joining operations and pipe installation.

**END OF SECTION**





**SECTION 33 05 23.13**  
**UTILITY HORIZONTAL DIRECTIONAL DRILLING**

**PART 1 GENERAL**

1.01 SUBMITTALS

- A. Action Submittals:
  - 1. Description of how pilot hole drill will be steered and of how position and inclination of bore head will be monitored.
  - 2. Installation plan, including detailed plan and profile of bore plotted at scale no smaller than 1 inch equals 20 feet horizontal and vertical as well as a detailed plan for the fused pipe staging alignment.
- B. Informational Submittals: Record drawing plan and profile showing as constructed position of pipeline. Contractor to provide means of tracking and documenting accurate record drawings of HDD.

1.02 QUALITY ASSURANCE

- A. Provide key personnel with at least 5 years' experience in directional drilling and associated pipe installation, including pipe at least as large as 24 inches in diameter and at least as long as 2,000 linear feet. Key personnel include field supervisor and operators of directional drilling equipment, including position monitoring and steering equipment.

**PART 2 PRODUCTS**

2.01 HDPE PIPE

- A. As specified in Division 33, Utilities.

**PART 3 EXECUTION**

3.01 GENERAL

- A. A Geotechnical Report dated June 2017 by Larry M. Jacobs and Associates, Inc. is provided herein.
- B. A HDD Report dated June 2017 by CH2M HILL is provided herein.

3.02 PREPARATIONS

- A. Locate positions of entry and exit pits, establish elevation and horizontal datum for bore head control, and lay out pipe assembly area.

- B. Lay out and assemble pipe in manner that does not obstruct adjacent roads, nearby railroads, and commercial or residential activities adjacent to construction easements. Elevate pipe over streets or railroads as necessary to avoid disruption to traffic.
- C. Contractor to prepare a Traffic and Pedestrian Control Plan for the project including the pipe staging. Access to residences or businesses is not to be blocked. Contractor to provide ramps to cross staged pipe and or provide applicable detour signs to direct traffic to alternative streets. Control Plan to be prepared and signed by a licensed Florida P.E. and submitted to engineer for approval.
- D. Contractor to provide adequate signage and temporary safety fencing or barriers to direct and maintain pedestrian traffic around construction site.

### 3.03 DRILLING PILOT HOLE

- A. Drill pilot hole from entrance point to exit point following vertical and horizontal alignment shown.
- B. As pilot hole is advanced, plot actual horizontal and vertical alignment of pilot hole at intervals not exceeding 50 feet. Provide Engineer with position or inclination of pilot bore upon request.
- C. Alignment Requirements:
  - 1. Pilot hole exit point shall be within 10 feet horizontally of exit point location shown.
  - 2. Throughout its alignment, pilot hole shall be within 10 feet of horizontal alignment shown, and no shallower than vertical alignment shown.
  - 3. Alignment shall have no intermediate high points that might trap air in pipe after installation.
  - 4. Curvature of completed pilot hole shall not exceed that which after pipe installation will result in pipe wall stresses greater than 0.50 of yield stress.
- D. Acceptance: If pilot hole alignment fails to conform to specified requirements, drill new pilot hole with alignment meeting specified requirements.

### 3.04 REAMING PILOT HOLE AND PULLING PIPE

- A. Obtain Engineer's approval to proceed before enlarging pilot hole and pulling pipe into position.
- B. While pulling pipe, enlarge pilot hole ahead of pipe to diameter sufficient for pulling pipe into position.

- C. While pulling pipe, handle pipe in manner that does not overstress pipe. Limit radius of curvature along length of pipe during installation to minimum recommended radius by pipe manufacturer. If pipe buckles or is otherwise damaged, remove damaged section and replace it with new pipe.
- D. A single stage pull should be performed but no more than a 2-stage pull or one intermediate weld will be permitted while pulling pipe.
- E. Staging of pipe on the Okaloosa Island side, as shown as the Drawings, is an available option. Contractor to submit a fused pipe staging alignment plan.
- F. Pull pipe so that minimum of 10 feet of pipe is exposed at both ends of bore.

### 3.05 CLEANING PIPE ENDS

- A. After pulling pipe, cut exposed HDPE pipe ends to location and elevations as shown on drawings. Cut pipe ends shall be properly cleaned for installation of fittings per manufacturer's recommendations.

### 3.06 HANDLING AND DISPOSAL OF DRILLING MUD AND CUTTINGS

- A. Make adequate provisions for handling and containing muddy water, drilling mud, and cuttings during drilling operations. Do not discharge these contaminants into waterways.
- B. Construct mud pits at entry and exit points in manner that completely contains mud and prevents its escape.
- C. When onsite provisions for storing muddy water, drilling mud, or cuttings onsite are exceeded, haul contaminants away to suitable legal disposal Site.
- D. Conduct directional drilling operation in such manner that drilling mud is not forced through channel subbottom into waterways, or into other areas where it might be objectional.

### 3.07 END FITTINGS

- A. Fabricate and install mitered fittings at ends of pipe for attachment of adjacent sections of pipe. Fitting angles shall correspond to field conditions and shall be as approved by Engineer.

### 3.08 PRESSURE TESTING

- A. After pulling pipe into position but before attachment of adjacent sections of pipe, pressure test pipe as specified in Section 33 05 01.10, High Density Polyethylene Pressure Pipe and Fittings.

3.09 PIPE ABANDONMENT

- A. In event of failure to install pipe, retain possession of pipe and remove it from Site. Completely fill borehole with grout or sand so as to prevent future settlement.
- B. If pipe cannot be withdrawn, cut pipe off at least 3 feet below ground surface and cap ends of pipe with blind flange. Fill annular space with grout.

3.10 SURFACE RESTORATION

- A. Contractor to restore site to original conditions following completion of Work. Exit pit to be backfilled with sand and a gravel base coarse to match existing driveway.
- B. As specified in Section 32 12 16, Asphalt Paving.

3.11 SUPPLEMENTS

- A. The supplements listed below, following “END OF SECTION,” are part of this Specification.
  - 1. 17-170 Brooks Bridge Report of Subsurface Exploration.
  - 2. Brooks Bridge Water Main Replacement Project.

**END OF SECTION**



June 23, 2017

Mr. Kevin Waddell  
CH2M Hill  
25 West Cedar Street, Suite 350  
Pensacola, Florida 32502

**SUBJECT: Revised Report of Subsurface Exploration  
Brooks Bridge Borings  
Okaloosa County, Florida  
LMJ File #: 17-170**

Dear Mr. Waddell:

This letter forwards our revised results of our subsurface exploration for the subject project. This letter offers the requested additional information and should replace our original letter for this project dated May 4, 2017. The purpose of this exploration was to determine the general subsurface conditions at the proposed boring locations. Our exploration consisted of three Standard Penetration Test borings (B-1 to B-3), visual classification of the samples obtained in the field by our engineering staff, and laboratory testing on selected soil samples. The requested borings are located west of Brooks Bridge in Okaloosa County, and a site vicinity map is attached as **Figure #1** and our boring location plan is attached as **Figure #2**. Boring B-1 was drilled on a sand beach next to the water, boring B-2 was drilled on the edge of a parking lot, and boring B-3 was drilled in the water. The logs of boring are attached as **Figure #3**.

To examine the general subsurface conditions at the requested boring locations, an LMJ crew drilled three Standard Penetration Test (SPT) borings. The two borings on land were drilled to a depth of 76 feet and the one boring drilled in the water from a pontoon boat was drilled to a depth of 61 feet below the boat deck. The SPT consists of driving a 2-inch diameter split spoon sampler into the ground using a 140-pound hammer dropped 30 inches. Our drill crew uses a safety hammer. The number of blows required to drive the sampler one foot after seating it 6 inches is referred to as the blow count or "N" value and represents the relative density of subsurface soils. "N" values can be found in **Figure #3** adjacent to the soil descriptions. Five SPT samples were taken in the upper 11 feet, and the borings were sampled at 5 foot increments thereafter. A part of boring B-3 was sampled continuously via SPT. The land borings were backfilled with soil cuttings upon completion, which is typical for our area. The borehole in the water would collapse once the drilling mud was removed.

The borings were drilled in general accordance with ASTM D1586 using a truck mounted drill rig on land or a tripod mounted drilling on the pontoon boat. The borings with the truck were advanced with augers between the SPT sampling above the water table and below the water table with the mud jetting technique and a bentonite drilling mud. Our tripod mounted drilling rig uses the mud jetting technique and a bentonite drilling mud. The drillers typically switch to the mud drilling method when the water level is encountered. The approximate boring locations are shown on the attached **Figure #2**. The boring locations were marked in the field with a hand held GPS unit and the GPS coordinates are noted on the boring location plan. The horizontal datum is WGS 1984



(based on Google Earth). The depth, number and location of the borings were selected by our client.

A description of regional and site geology is provided below, and this geology discussion is taken from the "Report of Investigation No. 92, Shallow Stratigraphy of Okaloosa County and Vicinity, Florida", which is published by the Florida Department of Natural Resources. The Okaloosa County area is a transition zone between the clastic dominated sediments on the edge of the Gulf of Mexico Sedimentary Basin to the west and the limestone dominated sediments of the Florida Peninsula Sedimentary Province to the east of the county. More specifically, published cross section data generally indicates that the vicinity of the project is underlain by Citronelle/Pliocene-Pleistocene Sands Undifferentiated from the ground surface to roughly 100-150 feet below grade. The Pliocene-Pleistocene Sands formation consists of white to light gray quartz sand. Clay lenses are sometimes encountered, associated with shell beds. The Citronelle formation in Okaloosa County is primarily variable color quartz sand which contains discontinuous layers of gravel, clay and limonite. Below the upper formation, the site is underlain by Intracoastal Formation and the Four Mile Village Member of the Intracoastal Formation to a rough depth of 450-500 feet. The Intracoastal formation typically consists of poorly consolidated, sandy, clayey, micro fossiliferous limestone. The Four Mile Village Member is phosphatic sand or sandstone composed of moderately rounded medium to coarse grained quartz and phosphate grains. Below the Intracoastal Formation, the Bruce Creek Limestone extends to a depth of roughly 650 feet. The Bruce Creek Limestone consists of white to light gray, moderately indurated, fossiliferous, granular limestone. The Bruce Creek contains pyrite, phosphate, mica, clay and glauconite in quantities less than one percent.

A general description of the soil conditions encountered at the boring locations is included in this paragraph. A detailed description of the subsurface conditions encountered at the boring locations can be found on **Figure #3**. Boundaries between soil layers and soil depths should be considered approximate since the actual transition between layers may be gradual. In general, the three borings typically encountered white, gray, brown and dark brown, very loose, loose, medium dense and dense poorly graded sand to 44-48 feet, over white, tan, brown and gray very dense poorly graded sand, poorly graded sand with silt and silty sand to the bottom of the borings at the 61 and 76 foot depth. Note that borings B-1 and B-3 encountered layers of gray to gray/green medium stiff to soft clay, soft sandy clay, soft sandy clay and shell and stiff sandy silt with clay between 42-48 feet below grade or the boat deck.

Groundwater depth below existing grade at the time of drilling are noted on the logs of boring, and the groundwater level was noted early in the morning. Groundwater levels will vary with the amount of local rainfall, the tide and changes in site drainage characteristics and may be different at other times. Laboratory testing for this project consisted of moisture content testing, percent passing a number #200 sieve, and Atterberg Limits testing. The results of the laboratory testing are noted on the logs of boring next to the sample tested and in **Table #1** below. Laboratory data sheets and calculations are provided in **Appendix A**.



**Table #1: Laboratory Test Results**

Boring Number	Sample Number	Moisture Content %	Percent Passing No. 200 Sieve	Liquid Limit	Plastic Limit
B-1	1	9.1	0.3	-	-
B-1	2	21.9	0.7	-	-
B-1	3	29.8	1.1	-	-
B-1	4	26.2	0.7	-	-
B-1	5	28.7	0.8	-	-
B-1	6	24.3	1.5	-	-
B-1	7	23.0	2.3	-	-
B-1	8	22.9	2.9	-	-
B-1	9	22.9	2.3	-	-
B-1	10	22.4	4.5	-	-
B-1	11	29.0	13.4	-	-
B-1	12	26.0	65.0	-	-
B-1	13	21.5	6.2	-	-
B-1	14	24.0	5.8	-	-
B-1	15	24.0	4.7	-	-
B-2	1	2.3	1.5	-	-
B-2	3	3.1	1.1	-	-
B-2	7	25.2	1.0	-	-
B-2	10	23.5	2.2	-	-
B-2	11 (Top)	26.9	9.0	-	-
B-2	11 (Bottom)	24.3	2.3	-	-
B-2	13	22.2	2.9	-	-
B-2	14	22.7	6.8	-	-
B-2	15	23.5	26.1	-	-
B-2	16	25.9	5.7	-	-
B-2	18	24.0	3.5	-	-
B-3	1	23.4	0.7	-	-
B-3	2	21.0	1.6	-	-
B-3	5	24.9	1.7	-	-
B-3	7	25.1	1.3	-	-
B-3	9	25.1	2.3	-	-
B-3	10	29.3	42.7	28	15
B-3	11	30.7	70.4	39	20
B-3	14	24.7	6.6	-	-

Regardless of the care exercised in performing a subsurface exploration, the possibility always exists that soil and/or groundwater conditions will differ from those encountered at the specific boring locations. In addition, construction operations may alter the soil conditions.



We hope that this letter provides sufficient information for your current requirements. If you have any questions or comments, please do not hesitate to call.

Sincerely,

**LARRY M. JACOBS & ASSOCIATES, INC.**

Terry Niemann  
Project Manager

Attachments



# VICINITY MAP

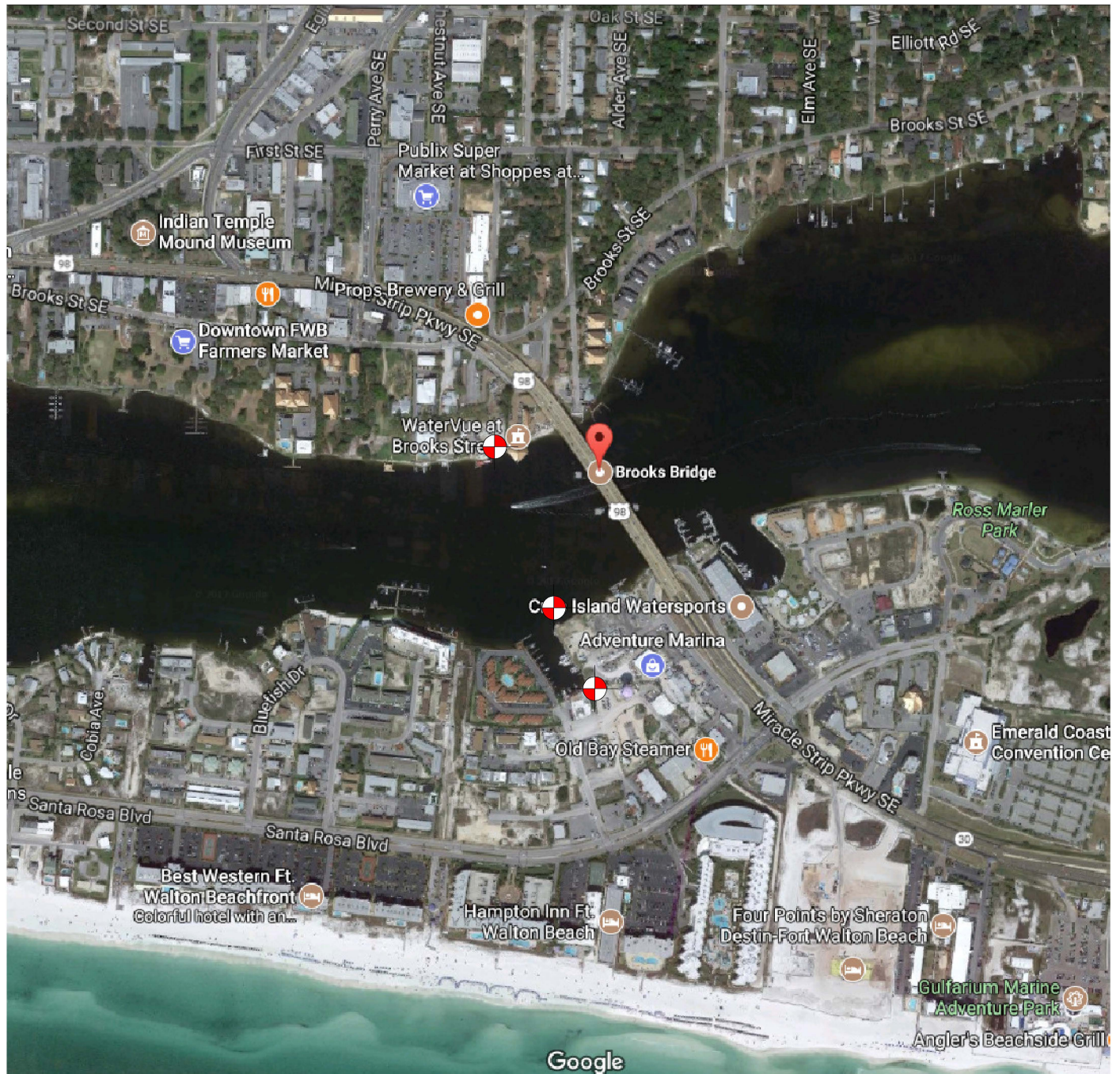

STANDARD PENETRATION TEST BORING  
ALL BORING LOCATIONS ARE APPROXIMATE

Project #: 17-170 Scale: NTS

Date: 05/04/2017 Checked By: TDN

Project: Brooks Bridge

Location: Okaloosa County, Florida



# BORING LOCATION PLAN

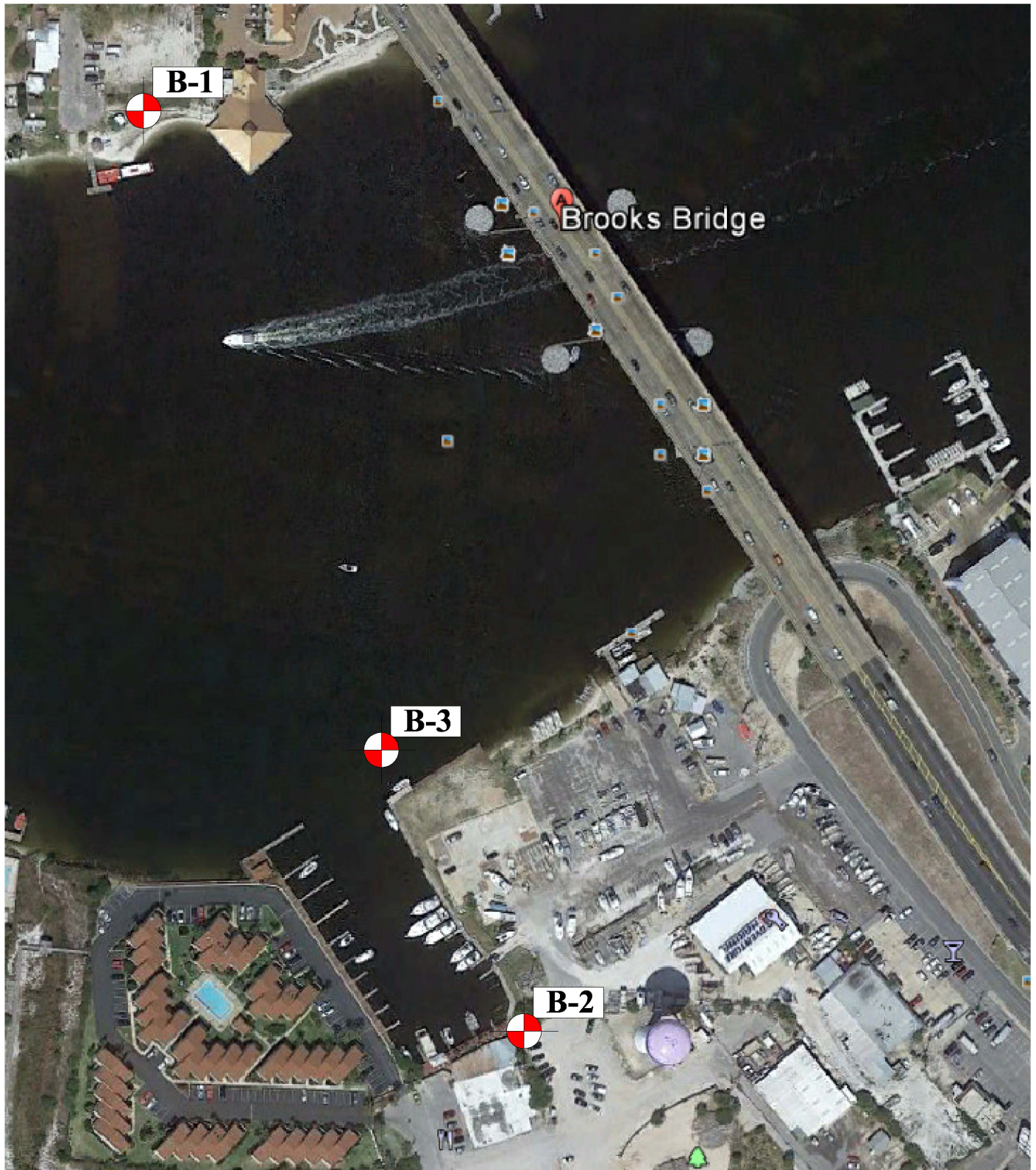

STANDARD PENETRATION TEST BORING  
ALL BORING LOCATIONS ARE APPROXIMATE

Project #: 17-170 Scale: NTS

Date: 06/21/2017 Checked By: TDN

Project: Brooks Bridge

Location: Okaloosa County, Florida



# BORING LOGS

Figure #3

## B-1

04-20-17

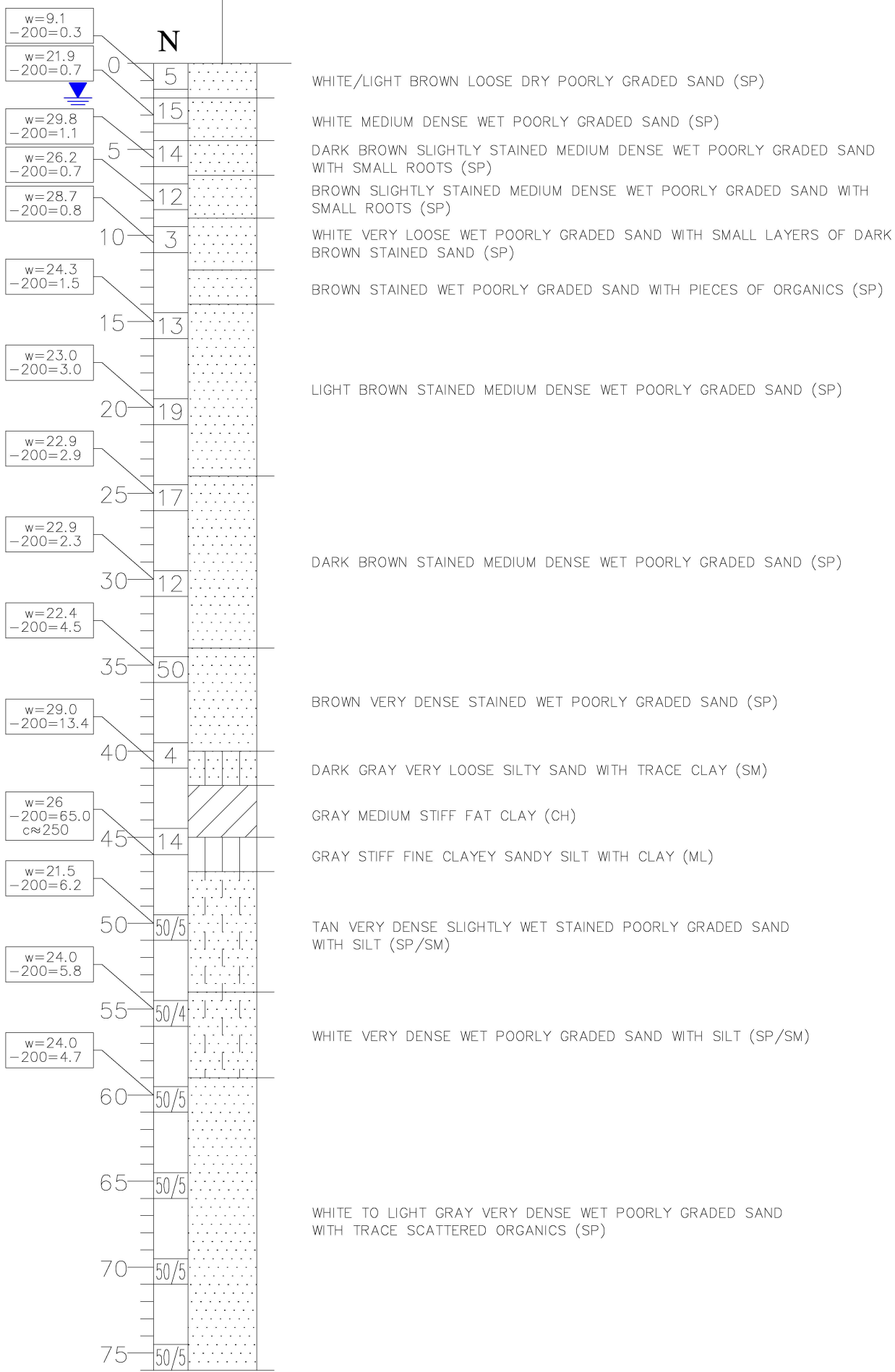

### HAMMER BLOWS:

0 FT SAMPLE:	2/2/3
2 FT SAMPLE:	5/7/8
5 FT SAMPLE:	5/7/7
7 FT SAMPLE:	3/5/7
10 FT SAMPLE:	2/2/1
15 FT SAMPLE:	5/6/7
20 FT SAMPLE:	7/9/10
25 FT SAMPLE:	5/8/9
30 FT SAMPLE:	6/4/8
35 FT SAMPLE:	14/23/27
40 FT SAMPLE:	2/2/2
45 FT SAMPLE:	3/7/7
50 FT SAMPLE:	30/50/50/5"
55 FT SAMPLE:	29/50/50/4"
60 FT SAMPLE:	28/50/50/5"
65 FT SAMPLE:	23/50/50/5"
70 FT SAMPLE:	27/50/50/5"
75 FT SAMPLE:	28/50/50/5"

DRILLER: DON JONES  
DRILLING METHOD: MUD JETTING AND TRUCK MOUNTED DRILLING RIG

NOTE: SANDS APPEARED TO BE FINE BASED ON VISUAL MANUAL CLASSIFICATION.

### LEGEND

	SAND		SLIGHTLY SILTY SAND
	SILTY SAND		SILT
	CLAY		CLAYEY SAND
	PEAT		GRAVEL

GRANULAR MATERIALS	
SPT BLOWS/FOOT (N)	RELATIVE DENSITY
0-4	VERY LOOSE
5-10	LOOSE
11-30	MEDIUM DENSE
31-50	DENSE
GREATER THAN 50	VERY DENSE

SILTS AND CLAY	
SPT BLOWS/FOOT (N)	RELATIVE DENSITY
0-2	VERY SOFT
3-4	SOFT
5-8	MEDIUM STIFF
9-16	STIFF
17-32	VERY STIFF
GREATER THAN 32	HARD

### SYMBOLS:

- GNE= GROUNDWATER NOT ENCOUNTERED AT TIME OF DRILLING
- N = STANDARD PENETRATION RESISTANCE IN BLOWS PER FOOT
- = ENCOUNTERED GROUNDWATER LEVEL
- = ENCOUNTERED PERCHED WATER LEVEL
- 50/2 = NUMBER OF BLOWS REQUIRED (50) TO ADVANCE SPLIT SPOON SAMPLER A SPECIFIC DISTANCE (2) INCHES
- HW= SPLIT SPOON SAMPLER ADVANCED UNDER WEIGHT OF ROD AND HAMMER
- HA= HAND AUGER
- = SHELBY TUBE SAMPLE
- w= NATURAL MOISTURE CONTENT (%)
- 200= FINES PASSING #200 SIEVE (%)
- O.C.= ORGANIC CONTENT (%)
- LL= ATTERBERG LIMITS (%)
- LL=LIQUID LIMIT, PL=PLASTIC LIMIT
- LI= LIQUIDITY INDEX
- c<sub>∞</sub> APPROXIMATE COHESION VALUE (PSF) BASED ON POCKET PENETROMETER READINGS
- K<sub>v</sub>= SATURATED VERTICAL HYDRAULIC CONDUCTIVITY (FT/DAY)
- γ<sub>d</sub>= DRY UNIT WEIGHT (PCF)
- γ<sub>m</sub>= ESTIMATED MOIST UNIT WEIGHT (PCF)
- γ<sub>b</sub>= ESTIMATED BOUYANT UNIT WEIGHT (PCF)
- φ= ESTIMATED ANGLE OF INTERNAL FRICTION (DEGREES)

### NOTES:

- 1) SPT BORINGS PERFORMED IN GENERAL ACCORDANCE WITH ASTM D1586
- 2) SUBSURFACE CONDITIONS ARE AT BORING LOCATIONS AND ACTUAL CONDITIONS BETWEEN BORINGS MAY VARY
- 3) ALL CLASSIFICATIONS ARE BASED ON VISUAL EXAMINATION UNLESS ACCOMPANIED BY LABORATORY TEST RESULTS
- 4) BOUNDARIES BETWEEN SOIL LAYERS SHOULD BE CONSIDERED APPROXIMATE AS THE ACTUAL TRANSITION MAY BE GRADUAL
- 5) DEPTH OF BORING IS BELOW EXISTING GRADE AT TIME OF DRILLING
- 6) ELEVATIONS ESTIMATED FROM PROVIDED TOPOGRAPHIC SURVEY

Project #: 17-170 Scale: NTS

Date: 06/21/2017 Checked By: TDN

Project: Brooks Bridge

Location: Okaloosa County, Florida



# BORING LOGS

Figure #3

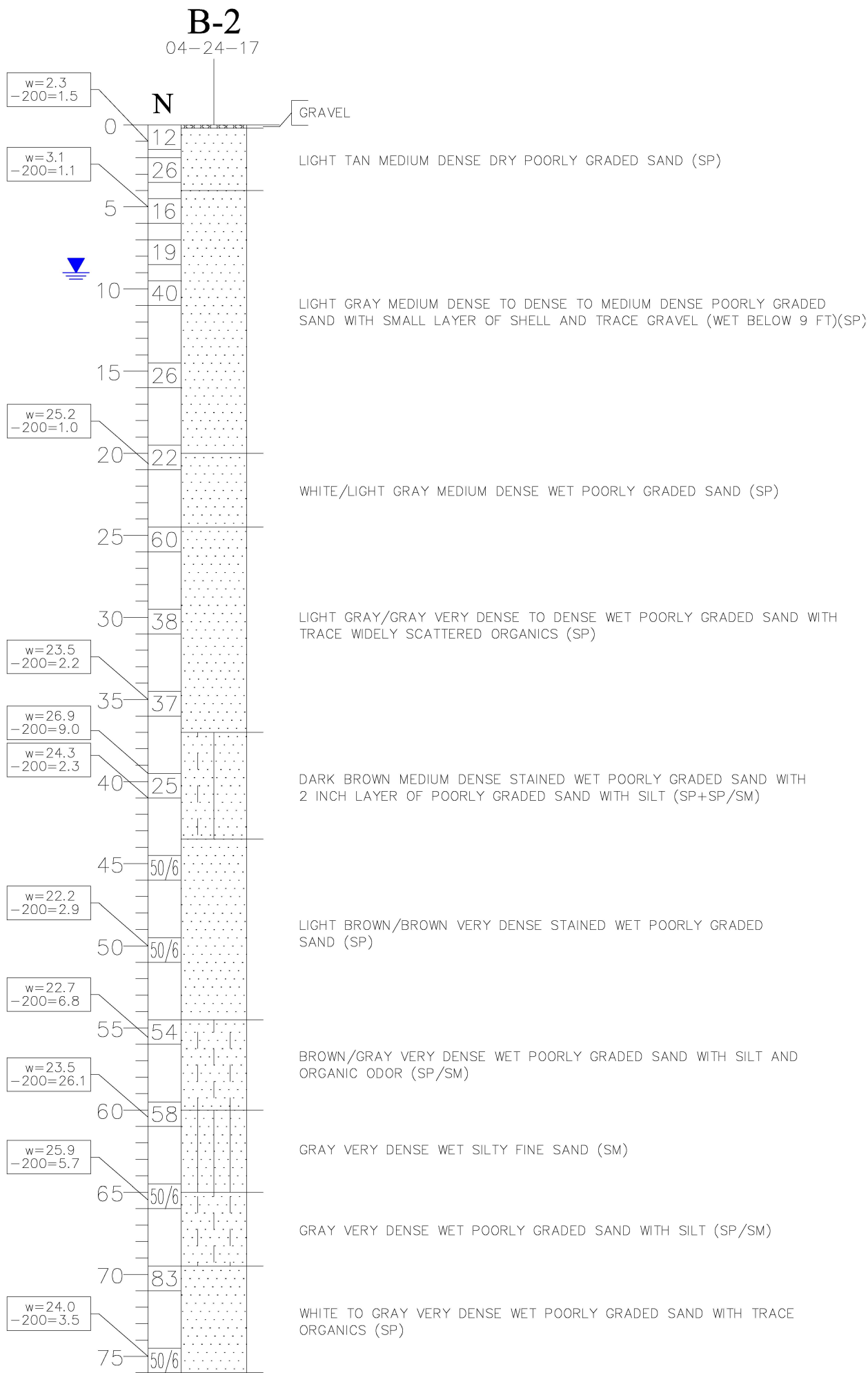

HAMMER BLOWS:

0 FT SAMPLE:	5/5/7
2 FT SAMPLE:	10/11/15
5 FT SAMPLE:	5/7/9
7 FT SAMPLE:	9/9/10
10 FT SAMPLE:	10/20/20
15 FT SAMPLE:	7/13/13
20 FT SAMPLE:	5/10/12
25 FT SAMPLE:	10/30/30
30 FT SAMPLE:	10/17/21
35 FT SAMPLE:	8/17/20
40 FT SAMPLE:	7/10/15
45 FT SAMPLE:	15/21/50/5"
50 FT SAMPLE:	22/35/50/5"
55 FT SAMPLE:	19/23/31
60 FT SAMPLE:	15/25/33
65 FT SAMPLE:	28/50/5
70 FT SAMPLE:	31/35/48
75 FT SAMPLE:	40/50/6"

DRILLER: RICHARD WILSON  
DRILLING METHOD: MUD JETTING AND TRUCK MOUNTED DRILLING RIG

NOTE: SANDS APPEARED TO BE FINE BASED ON VISUAL MANUAL CLASSIFICATION.

LEGEND

	SAND		SLIGHTLY SILTY SAND
	SILTY SAND		SILT
	CLAY		CLAYEY SAND
	PEAT		GRAVEL

GRANULAR MATERIALS	
SPT BLOWS/FOOT (N)	RELATIVE DENSITY
0-4	VERY LOOSE
5-10	LOOSE
11-30	MEDIUM DENSE
31-50	DENSE
GREATER THAN 50	VERY DENSE

SILTS AND CLAY	
SPT BLOWS/FOOT (N)	RELATIVE DENSITY
0-2	VERY SOFT
3-4	SOFT
5-8	MEDIUM STIFF
9-16	STIFF
17-32	VERY STIFF
GREATER THAN 32	HARD

SYMBOLS:

- GNE= GROUNDWATER NOT ENCOUNTERED AT TIME OF DRILLING
- N = STANDARD PENETRATION RESISTANCE IN BLOWS PER FOOT
- = ENCOUNTERED GROUNDWATER LEVEL
- = ENCOUNTERED PERCHED WATER LEVEL
- 50/2 = NUMBER OF BLOWS REQUIRED (50) TO ADVANCE SPLIT SPOON SAMPLER A SPECIFIC DISTANCE (2) INCHES
- HW= SPLIT SPOON SAMPLER ADVANCED UNDER WEIGHT OF ROD AND HAMMER
- HA= HAND AUGER
- = SHELBY TUBE SAMPLE
- w= NATURAL MOISTURE CONTENT (%)
- 200= FINES PASSING #200 SIEVE (%)
- O.C.= ORGANIC CONTENT (%)
- LL= ATTERBERG LIMITS (%)
- LL=LIQUID LIMIT, PL=PLASTIC LIMIT
- LI= LIQUIDITY INDEX
- c<sub>u</sub>≈ APPROXIMATE COHESION VALUE (PSF) BASED ON POCKET PENETROMETER READINGS
- K<sub>v</sub>= SATURATED VERTICAL HYDRAULIC CONDUCTIVITY (FT/DAY)
- γ<sub>d</sub>= DRY UNIT WEIGHT (PCF)
- γ<sub>m</sub>= ESTIMATED MOIST UNIT WEIGHT (PCF)
- γ<sub>b</sub>= ESTIMATED BOUYANT UNIT WEIGHT (PCF)
- φ= ESTIMATED ANGLE OF INTERNAL FRICTION (DEGREES)

NOTES:

- 1) SPT BORINGS PERFORMED IN GENERAL ACCORDANCE WITH ASTM D1586
- 2) SUBSURFACE CONDITIONS ARE AT BORING LOCATIONS AND ACTUAL CONDITIONS BETWEEN BORINGS MAY VARY
- 3) ALL CLASSIFICATIONS ARE BASED ON VISUAL EXAMINATION UNLESS ACCOMPANIED BY LABORATORY TEST RESULTS
- 4) BOUNDARIES BETWEEN SOIL LAYERS SHOULD BE CONSIDERED APPROXIMATE AS THE ACTUAL TRANSITION MAY BE GRADUAL
- 5) DEPTH OF BORING IS BELOW EXISTING GRADE AT TIME OF DRILLING
- 6) ELEVATIONS ESTIMATED FROM PROVIDED TOPOGRAPHIC SURVEY

Project #: 17-170 Scale: NTS

Date: 06/21/2017 Checked By: TDN

Project: Brooks Bridge

Location: Okaloosa County, Florida



# BORING LOGS

Figure #3

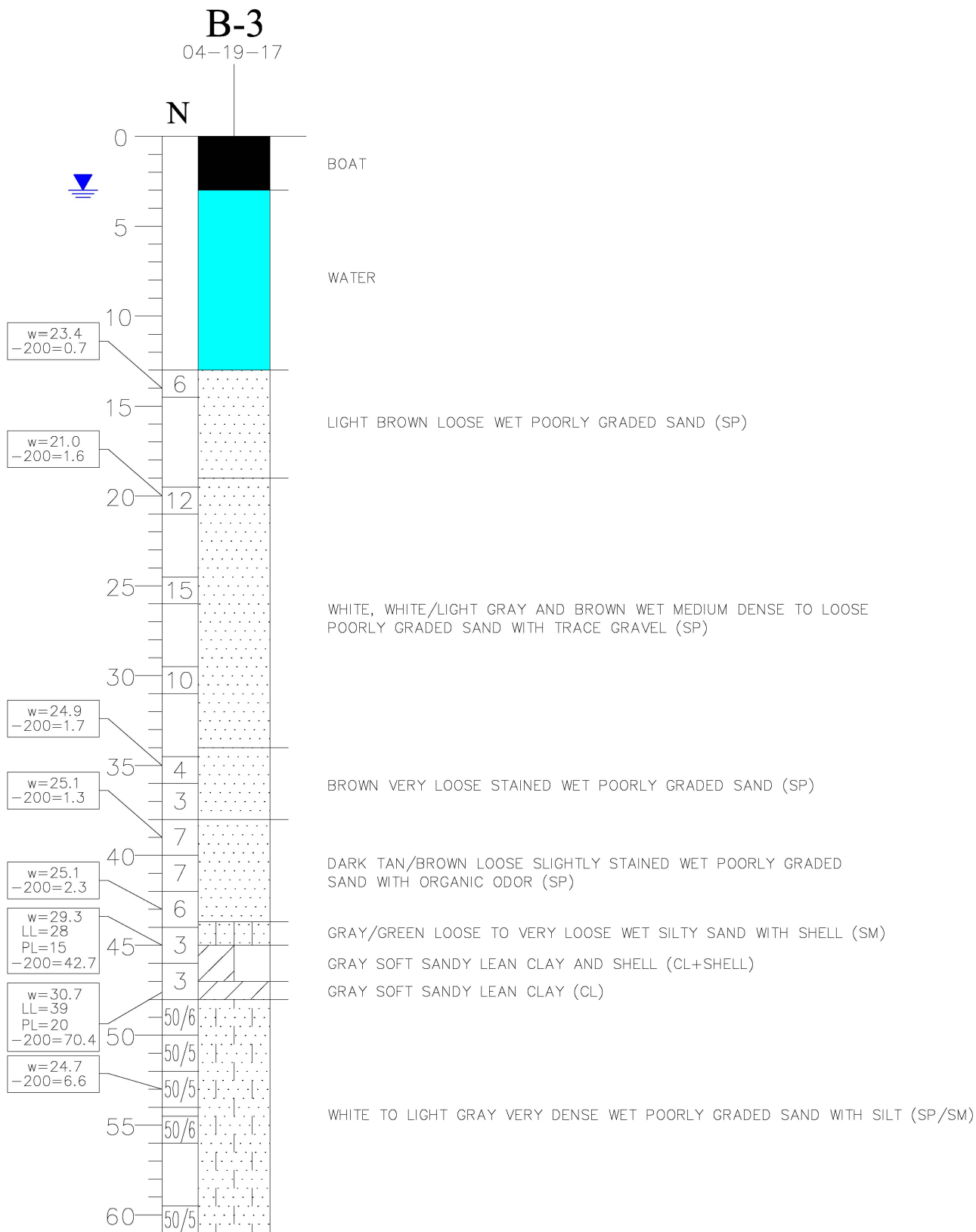

**HAMMER BLOWS:**

- 13 FT SAMPLE: 2/2/4
- 20 FT SAMPLE: 4/5/7
- 25 FT SAMPLE: 5/7/8
- 30 FT SAMPLE: 7/5/5
- 35 FT SAMPLE: 2/2/2
- 36 FT SAMPLE: 2/1/2
- 38 FT SAMPLE: 2/3/4
- 40 FT SAMPLE: 3/3/4
- 42 FT SAMPLE: 3/3/3
- 44 FT SAMPLE: 3/2/1
- 46 FT SAMPLE: 1/2/1
- 48 FT SAMPLE: 48/50/50/6"
- 50 FT SAMPLE: 42/50/50/5"
- 53 FT SAMPLE: 50/50/5"
- 55 FT SAMPLE: 50/50/6"
- 60 FT SAMPLE: 37/50/50/5"

DRILLER: DON JONES  
DRILLING METHOD: MUD JETTING AND PANTOON BOAT MOUNTED TRIPOD DRILLING RIG.

NOTE: SANDS APPEARED TO BE FINE BASED ON VISUAL MANUAL CLASSIFICATION.

**LEGEND**

	SAND		SLIGHTLY SILTY SAND
	SILTY SAND		SILT
	CLAY		CLAYEY SAND
	PEAT		GRAVEL

GRANULAR MATERIALS	
SPT BLOWS/FOOT (N)	RELATIVE DENSITY
0-4	VERY LOOSE
5-10	LOOSE
11-30	MEDIUM DENSE
31-50	DENSE
GREATER THAN 50	VERY DENSE

SILTS AND CLAY	
SPT BLOWS/FOOT (N)	RELATIVE DENSITY
0-2	VERY SOFT
3-4	SOFT
5-8	MEDIUM STIFF
9-16	STIFF
17-32	VERY STIFF
GREATER THAN 32	HARD

**SYMBOLS:**

- GNE= GROUNDWATER NOT ENCOUNTERED AT TIME OF DRILLING
- N = STANDARD PENETRATION RESISTANCE IN BLOWS PER FOOT
- = ENCOUNTERED GROUNDWATER LEVEL
- = ENCOUNTERED PERCHED WATER LEVEL
- = NUMBER OF BLOWS REQUIRED (50) TO ADVANCE SPLIT SPOON SAMPLER A SPECIFIC DISTANCE (2) INCHES
- HW= SPLIT SPOON SAMPLER ADVANCED UNDER WEIGHT OF ROD AND HAMMER
- HA= HAND AUGER
- = SHELBY TUBE SAMPLE
- w= NATURAL MOISTURE CONTENT (%)
- 200= FINES PASSING #200 SIEVE (%)
- O.C.= ORGANIC CONTENT (%)
- LL= ATTERBERG LIMITS (%)
- LL=LIQUID LIMIT, PL=PLASTIC LIMIT
- LI= LIQUIDITY INDEX
- c<sub>u</sub>≈ APPROXIMATE COHESION VALUE (PSF) BASED ON POCKET PENETROMETER READINGS
- K<sub>v</sub>= SATURATED VERTICAL HYDRAULIC CONDUCTIVITY (FT/DAY)
- γ<sub>d</sub>= DRY UNIT WEIGHT (PCF)
- γ<sub>m</sub>= ESTIMATED MOIST UNIT WEIGHT (PCF)
- γ<sub>b</sub>= ESTIMATED BOUYANT UNIT WEIGHT (PCF)
- φ= ESTIMATED ANGLE OF INTERNAL FRICTION (DEGREES)

**NOTES:**

- 1) SPT BORINGS PERFORMED IN GENERAL ACCORDANCE WITH ASTM D1586
- 2) SUBSURFACE CONDITIONS ARE AT BORING LOCATIONS AND ACTUAL CONDITIONS BETWEEN BORINGS MAY VARY
- 3) ALL CLASSIFICATIONS ARE BASED ON VISUAL EXAMINATION UNLESS ACCOMPANIED BY LABORATORY TEST RESULTS
- 4) BOUNDARIES BETWEEN SOIL LAYERS SHOULD BE CONSIDERED APPROXIMATE AS THE ACTUAL TRANSITION MAY BE GRADUAL
- 5) DEPTH OF BORING IS BELOW EXISTING GRADE AT TIME OF DRILLING
- 6) ELEVATIONS ESTIMATED FROM PROVIDED TOPOGRAPHIC SURVEY

Project #: 17-170 Scale: NTS

Date: 06/21/2017 Checked By: TDN

Project: Brooks Bridge

Location: Okaloosa County, Florida

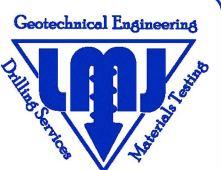

# Appendix A

# Laboratory Test Assignments

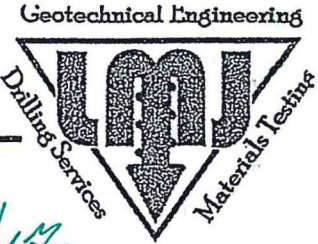

Project No: 14-170  
 Project: Brook Bridge  
 County: \_\_\_\_\_  
 Client: \_\_\_\_\_

Engineer: VV Date: 04/26/17

Boring No.	Sample No.	Depth of Sample	Description of Sample	Soil Property Tests										Soil Strength Tests					
				Sieve Analysis (ASTM C136)	#200 Sieve (ASTM D440)	Hydrometer (ASTM D422)	Atterberg Limits (ASTM D4318)	Natural Moisture	Unit Weight	Organic Content	Permeability	Specific Gravity	Unconfined/Confined Compression Test	LBR/CBR	Direct Shear Test	Consolidation (ASTM D2433)	Other:		
B3	1				X				X										
	2				X				X										
	5				X				X										
	7				X				X										
	<del>11</del>				<del>X</del>				<del>X</del>										
	14		<del>Grey silty sand clay</del>		X				X										

V  
OK  
105  
+ PDW



**WATER CONTENT & WASH #200 DETERMINATION ASTM D2216 & D1140**

Project #: 17-170

In Oven: 4/26/17

Project: Brook Bridge

Date of Testing: 4/27/17

Location: \_\_\_\_\_

Tested By: MaH

Description					
Boring-Sample #	B-3-1	B-3-2	B-3-5	B-3-7	B-3-14
Cup (Container) #	112	113	101	13	24
Wt. Cup + Wet Soil	168.30	182.52	189.93	173.97	194.25
Wt. Cup + Dry Soil	145.65	159.27	161.70	150.06	166.36
Wt. Cup	48.71	48.80	48.39	54.76	53.49
Wt. Dry Soil	96.94	110.47	113.31	95.30	112.87
Wt. Water	22.65 ✓	23.25	28.23	23.91	27.89
% Water	23.4 ✓	21.0 ✓	24.9 ✓	25.1 ✓	24.7 ✓
Wt. Cup + Dry Soil Washed	174.94	157.55	159.82	148.80	158.91
Wt. Dry Soil Washed	96.23	108.75	111.43	94.04	105.47
% Retained	99.27	98.44	98.34	98.68	93.44
% Passing	0.73 ✓	1.56 ✓	1.66 ✓	1.32 ✓	6.56 ✓

Description					
Boring-Sample #					
Cup (Container) #					
Wt. Cup + Wet Soil					
Wt. Cup + Dry Soil					
Wt. Cup					
Wt. Dry Soil					
Wt. Water					
% Water					
Wt. Cup + Dry Soil Washed					
Wt. Dry Soil Washed					
% Retained					
% Passing					



# Laboratory Test Assignments

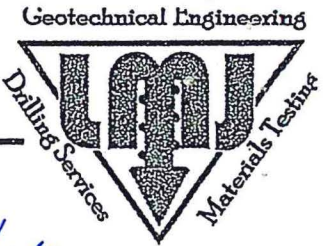

Project No: 14-170  
Project: Brooks Bridge  
County: \_\_\_\_\_  
Client: \_\_\_\_\_

Engineer: \_\_\_\_\_

Date: 04/20/14

Boring No.	Sample No.	Depth of Sample	Description of Sample	Soil Property Tests								Soil Strength Tests				
				Sieve Analysis (ASTM C136)	#200 Sieve (ASTM D1190)	Hydrometer (ASTM D422)	Atterberg Limits (ASTM D4318)	Natural Moisture	Unit Weight	Organic Content	Permeability	Specific Gravity	Unconfined/Confined Compression Test	LBR/CBR	Direct Shear Test	Consolidation (ASTM D2453)
B3	9	bott	Gray/Br SS	X			X									
B3	10	bott	Gray Sandy Clay	X		X	X									
B3	11	bott	Gray Sl. Sandy Cl	X		X	X									

?  
?



**WATER CONTENT & WASH #200 DETERMINATION ASTM D2216 & D1140**

Project #: 17-170

In Oven: 4/20/17

Project: Brooks Bridge

Date of Testing: 4/21/17

Location: \_\_\_\_\_

Tested By: Matt

Description					
Boring-Sample #	B-3-9	B-3-10	B-3-11		
Cup (Container) #	100	118	72		
Wt. Cup + Wet Soil	191.03	152.11	136.56		
Wt. Cup + Dry Soil	162.55	128.77	116.15		
Wt. Cup	48.93	48.99	49.67		
Wt. Dry Soil	113.62	79.78	66.48		
Wt. Water	28.48	23.34	20.41		
% Water	25.1 ✓	29.3 ✓	30.7 ✓		
Wt. Cup + Dry Soil Washed	159.90	94.67	69.34		
Wt. Dry Soil Washed	110.97	45.68	19.67		
% Retained	97.67	57.26	29.59		
% Passing	2.33 ✓	42.74 ✓	70.41 ✓		

Description					
Boring-Sample #					
Cup (Container) #					
Wt. Cup + Wet Soil					
Wt. Cup + Dry Soil					
Wt. Cup					
Wt. Dry Soil					
Wt. Water					
% Water					
Wt. Cup + Dry Soil Washed					
Wt. Dry Soil Washed					
% Retained					
% Passing					

Since 1976



**Atterberg Limits (ASTM D4318 / AASHTO T89 & T90)**

Project: Brooks Bridge Job Number: 17-170  
 Location: \_\_\_\_\_ Boring & Sample Number: B-3-10  
 Description: \_\_\_\_\_  
 Depth: \_\_\_\_\_ Tested by: Matt Date: \_\_\_\_\_

*Liquid Limit Determination*

Can Number	GG	II	FF
Wgt. Wet Sample + Cup	33.73	30.41	31.91
Wgt. Dry Sample + Cup	30.30	27.48	28.64
Wgt. Cup	18.13	17.89	18.07
Wgt. Water	3.43	2.93	3.27
Wgt. Dry Sample	12.17	9.59	10.57
Water Content (%)	28.2%	30.6%	30.9%
Blow Count (N)	25	23	15

*Natural Moisture*

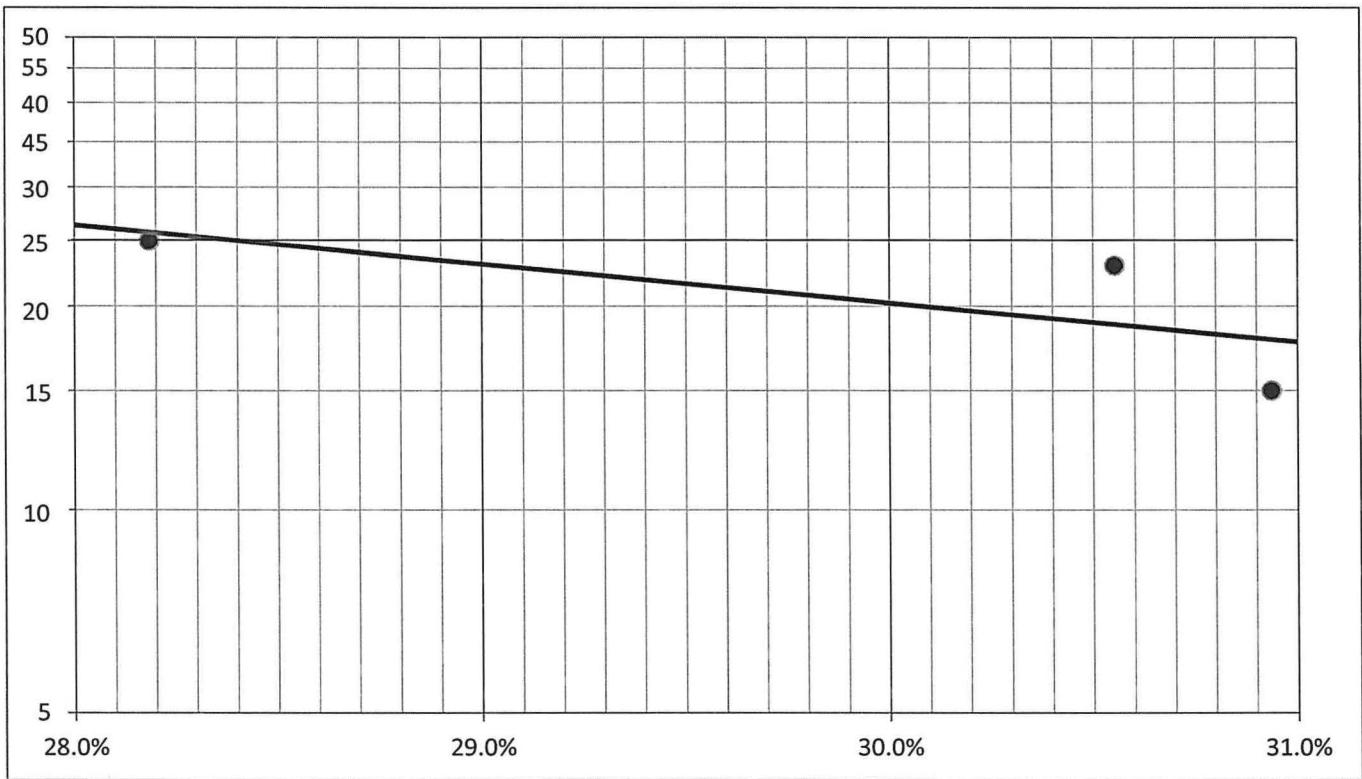
*Plastic Limit Determination*

Can Number	VV	
Wgt. Wet Sample + Cup	27.36	
Wgt. Dry Sample + Cup	26.20	
Wgt. Cup	18.30	
Wgt. Water	1.16	0.00
Wgt. Dry Sample	7.90	0.00
Water Content (%)	14.7%	--
Average Water Content	--	

*Plasticity Index Determination*

Liquid Limit:	28.4
Plastic Limit:	14.7
Plasticity Index (I <sub>p</sub> ):	13.7



Since 1976



**Atterberg Limits (ASTM D4318 / AASHTO T89 & T90)**

Project: Brooks Bridge Job Number: 17-170  
 Location: \_\_\_\_\_ Boring & Sample Number: B-3-11  
 Description: \_\_\_\_\_  
 Depth: \_\_\_\_\_ Tested by: Matt Date: \_\_\_\_\_

*Liquid Limit Determination*

Can Number	WW	EE	UU
Wgt. Wet Sample + Cup	30.10	32.33	29.12
Wgt. Dry Sample + Cup	26.83	28.23	25.73
Wgt. Cup	18.08	17.69	17.68
Wgt. Water	3.27	4.10	3.39
Wgt. Dry Sample	8.75	10.54	8.05
Water Content (%)	37.4%	38.9%	42.1%
Blow Count (N)	33	27	15

*Natural Moisture*

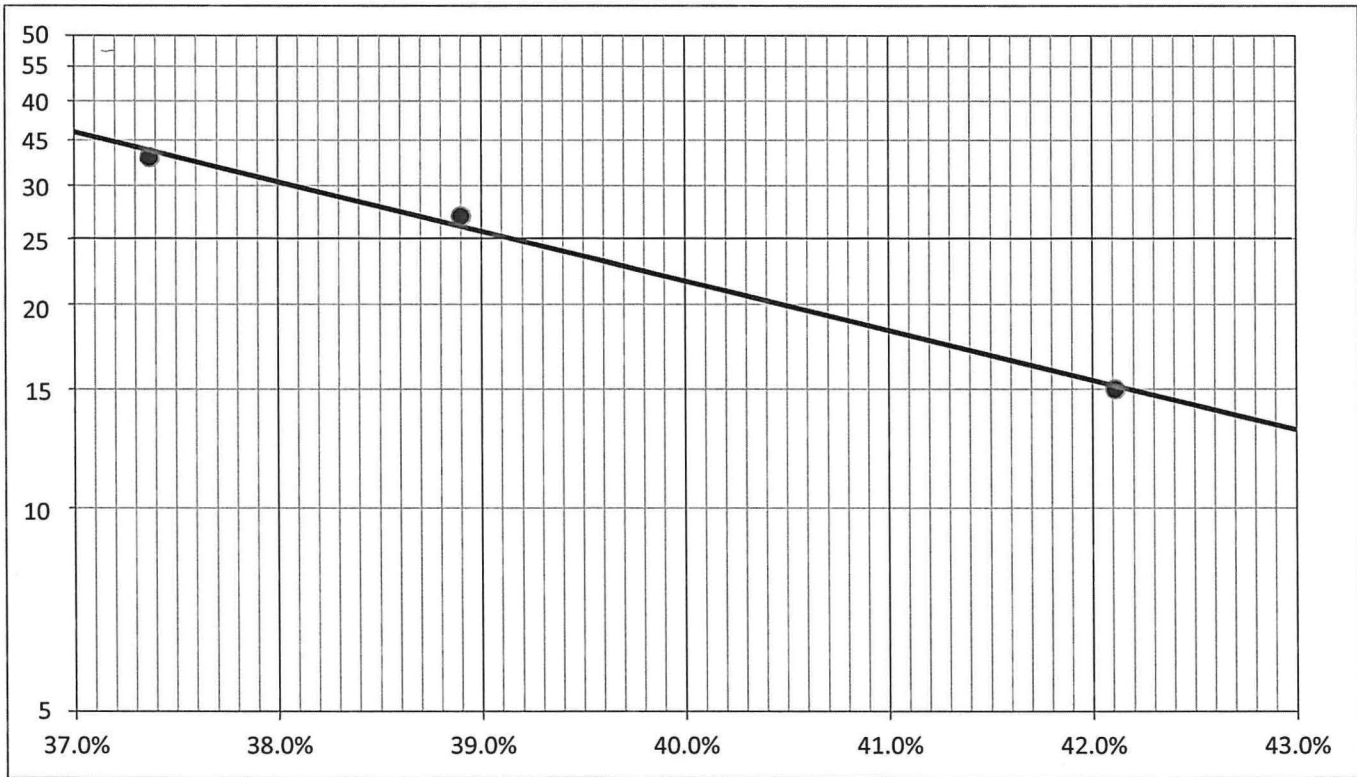
*Plastic Limit Determination*

Can Number	BB	
Wgt. Wet Sample + Cup	26.83	
Wgt. Dry Sample + Cup	25.33	
Wgt. Cup	17.76	
Wgt. Water	1.50	0.00
Wgt. Dry Sample	7.57	0.00
Water Content (%)	19.8%	--
Average Water Content	--	

*Plasticity Index Determination*

Liquid Limit:	39.1
Plastic Limit:	19.8
Plasticity Index (I <sub>p</sub> ):	19.3







**WATER CONTENT & WASH #200 DETERMINATION ASTM D2216 & D1140**

Project #: 17-170

In Oven: 4/28/17

Project: Brooks Bridge

Date of Testing: 4/31/17

Location: \_\_\_\_\_

Tested By: Matt

Description	Top				
Boring-Sample #	B-1-12	B-1-1	B-1-2	B-1-3	B-1-4
Cup (Container) #	120	112	72	28	13
Wt. Cup + Wet Soil	152.54	210.43	190.77	185.73	178.85
Wt. Cup + Dry Soil	131.09	196.88	165.39	154.98	153.09
Wt. Cup	48.43	48.68	49.65	51.94	54.75
Wt. Dry Soil	82.66	148.20	115.74	103.04	98.34
Wt. Water	21.45	13.55	25.38	30.75	25.76
% Water	25.9 ✓	9.1 ✓	21.9 ✓	29.8 ✓	26.2 ✓
Wt. Cup + Dry Soil Washed	77.36	196.48	164.62	153.90	152.40
Wt. Dry Soil Washed	28.93	147.80	114.97	101.96	97.65
% Retained	35.00	99.73 ✓	99.33 ✓	98.95 ✓	99.36 ✓
% Passing	65.06 ✓	0.27 ✓	0.67 ✓	1.05 ✓	0.70 ✓

Description					
Boring-Sample #	B-1-5	B-1-6	B-1-7	B-1-8	B-1-9
Cup (Container) #	5	119	116	100	106
Wt. Cup + Wet Soil	195.24	149.63	184.07	170.43	183.65
Wt. Cup + Dry Soil	162.85	129.88	158.85	147.83	158.53
Wt. Cup	50.01	48.52	49.02	48.94	48.95
Wt. Dry Soil	112.84	81.36	109.83	98.89	109.58
Wt. Water	32.39	19.75	25.22	22.60	25.12
% Water	28.7 ✓	24.3 ✓	23.0 ✓	22.9 ✓	22.9 ✓
Wt. Cup + Dry Soil Washed	161.95	128.68	155.61	144.92	156.02
Wt. Dry Soil Washed	111.94	80.16	106.59	95.98	107.07
% Retained	99.20	98.53 ✓	97.05 ✓	97.06 ✓	97.71 ✓
% Passing	0.80 ✓	1.47 ✓	2.95 ✓	2.94 ✓	2.29 ✓



**WATER CONTENT & WASH #200 DETERMINATION ASTM D2216 & D1140**

Project #: 17-170

In Oven: 4/28/17

Project: Brooks Bridge

Date of Testing: 4/31/17

Location: \_\_\_\_\_

Tested By: Matt

Description					
Boring-Sample #	B-1-10	B-1-11	B-1-13	B-1-14	B-1-15
Cup (Container) #	123	113	102	I	74
Wt. Cup + Wet Soil	197.74	187.57	187.28	184.76	167.90
Wt. Cup + Dry Soil	170.47	156.39	162.89	158.80	145.33
Wt. Cup	48.87	48.79	49.23	50.55	49.64
Wt. Dry Soil	121.60	107.60	113.66	108.25	95.69
Wt. Water	27.27	31.18	24.39	25.96	22.57
% Water	22.4 ✓	29.0 ✓	21.5 ✓	24.0 ✓	23.6 ✓
Wt. Cup + Dry Soil Washed	165.05	141.98	155.85	152.49	140.84
Wt. Dry Soil Washed	116.18	93.19	106.62	101.94	91.20
% Retained	95.54	86.61	93.81	94.17	95.31
% Passing	4.46 ✓	13.39 ✓	6.19 ✓	5.83 ✓	4.69 ✓

Description					
Boring-Sample #					
Cup (Container) #					
Wt. Cup + Wet Soil					
Wt. Cup + Dry Soil					
Wt. Cup					
Wt. Dry Soil					
Wt. Water					
% Water					
Wt. Cup + Dry Soil Washed					
Wt. Dry Soil Washed					
% Retained					
% Passing					







**WATER CONTENT & WASH #200 DETERMINATION ASTM D2216 & D1140**

Project #: 17-170

Project: Brooks Bridge

Location: \_\_\_\_\_

In Oven: 4/28/17

Date of Testing: 4/29/17

Tested By: Matt

Description	Bottom				Bottom
Boring-Sample #	B-2-1	B-2-3	B-2-7	B-2-10	B-2-11
Cup (Container) #	11	122	101	109	110
Wt. Cup + Wet Soil	156.56	190.87	158.94	182.21	202.16
Wt. Cup + Dry Soil	154.20	186.57	136.66	156.76	172.21
Wt. Cup	53.48	49.35	48.38	48.69	48.76
Wt. Dry Soil	100.72	137.22	88.28	108.07	123.45
Wt. Water	2.36	4.30	22.28	25.45	29.95
% Water	2.3 ✓	3.1 ✓	25.2 ✓	23.5 ✓	24.3 ✓
Wt. Cup + Dry Soil Washed	152.73	185.04	135.77 ✓	154.41	169.42
Wt. Dry Soil Washed	99.25	135.69	87.39	105.72	120.66
% Retained	98.54	98.89	98.99 ✓	97.83 ✓	97.74 ✓
% Passing	1.46 ✓	1.11 ✓	1.01 ✓	2.17 ✓	2.26 ✓

Description	Top				
Boring-Sample #	B-2-11	B-2-13	B-2-14	B-2-15	B-2-16 B-2-18
Cup (Container) #	75	115	0N	20	104 103
Wt. Cup + Wet Soil	162.72	186.37	186.67	180.21	186.78 194.95
Wt. Cup + Dry Soil	138.86	161.33	161.59	156.06	152.01 166.73
Wt. Cup	50.01	48.67	51.01	53.22	48.79 49.16
Wt. Dry Soil	88.85	112.66	110.58	102.84	109.22 117.57
Wt. Water	23.86	25.04	25.08	24.15	28.27 28.22
% Water	26.9 ✓	22.2 ✓	22.7 ✓	23.5 ✓	25.9 ✓ 24.0 ✓
Wt. Cup + Dry Soil Washed	130.83	158.02	154.13	129.19	151.80 162.62
Wt. Dry Soil Washed	80.82	109.35	103.12	75.97	103.01 113.46
% Retained	90.96	97.06	93.25	73.87	94.31 96.50
% Passing	9.04 ✓	2.94 ✓	6.75 ✓	26.13 ✓	5.69 3.50 ✓



HORIZONTAL DIRECTIONAL DRILLING CONTINGENCY AND  
FRAC-OUT RESPONSE PLAN

# Brooks Bridge Water Main Replacement Project

*Prepared for*

Okaloosa County, Florida

July 2017



2020 Southwest 4th Avenue  
Suite 300  
Portland, Oregon 97201



# 1 Introduction

This horizontal directional drilling frac-out contingency and response plan provides preventive and mitigative measures to be used by Okaloosa County and its contractor during pipeline installation beneath Santa Rosa Sound using horizontal directional drilling (HDD) technology. HDD is a proven and widely-accepted trenchless construction technique that is often preferred for its minimal impact to the ground surface and the environment. Although the great majority of HDD installations are completed without incident, it is possible for the drilling fluid used in the HDD process to be inadvertently be released to the ground surface, and this plan outlines the approach to manage this risk. This is a preliminary plan, and more specific procedures will be developed by the contractor based on site-specific conditions prior to the start of drilling, and submitted to the construction manager for review and approval.

The HDD process utilizes pressurized drilling fluids to achieve a variety of goals, including:

- Suspending and transferring soil cuttings to the ground surface at the bore entry or exit point
- Stabilizing the walls of the borehole to prevent borehole collapse
- Lubricating the drill string and, during pullback, the product pipe, to reduce frictional resistance
- Offset groundwater pressure to prevent flushing of the borehole
- Cooling the downhole equipment and cutting tools

HDD operations potentially pose a risk to water bodies and land-based features through inadvertent returns of pressurized drilling fluid to the surface, commonly referred to as “frac-outs” or “releases.” A frac-out occurs when the drilling fluid is released to the ground surface through pathways in the soil. Drilling fluid typically consists of a mixture of bentonite, fresh water, and soil cuttings. Bentonite is a natural clay, which is extremely hydrophilic and can absorb up to ten times its weight in water. A bentonite-based drilling fluid usually contains no more than 5 percent bentonite. However, bentonite slurry does not perform well in a saltwater environment, and other additives such as attapulgite clay or synthetic polymers can be added to improve performance. These mixtures are not hazardous or toxic, but could potentially affect the water quality of a water body if introduced, or cause damage to a surface feature such as a roadway.

Frac-outs can occur at any place along an HDD installation, although the potential is higher for occurrence near the entry and exit points (locations where soil cover over the advancing drill bit is relatively shallow). The contingency and response plan detailed in the following sections outlines measures:

- To minimize the potential for releases
- To monitor for the timely detection of frac-outs
- To minimize the impact should a frac-out occur through containment, corrective action, and cleanup
- For notification of affected parties

# 2 Planning and Prevention

All work will be performed in accordance with environmental permits and regulations. The contractor will use nontoxic bentonite or polymer mixtures of drilling mud to ensure that, if a frac-out occurs, it will not result in toxicity to marine life in Santa Rosa Sound.

The contractor performing the HDD must have experienced personnel onsite who are familiar with and experienced with the procedures for this type of installation. Before drilling activities begin, the contractor must submit any certifications and documentation of at least 5 years of experience for key personnel who will be performing drilling work, including the field supervisor, drill rig operator, steering hand, and pipe fusion welder. A trenchless construction inspector must be present for all HDD activities.

Before pilot drilling commences, a safety meeting is required, when the approved site-specific frac-out contingency plan will be discussed. The field crew members will review the procedures for preventing frac-outs and monitoring for frac-out detection, along with a review of the protocols for responding to a release, including the storage location of the response equipment and materials.

Prior to drilling, the entry and exit areas will be clearly marked and the limits of the work area(s) will be flagged. Erosion and sediment controls (including silt fencing, straw wattles, and temporary sediment trap) will be employed at the entry and exit worksites. A boat for water crossings to allow for monitoring along the alignment beneath Santa Rosa Sound and deploying silt curtains will be maintained at the site, along with appropriate boating safety equipment such as life jackets. In addition, containment equipment including earth-moving equipment, portable pumps, straw bales and straw wattles, hand tools, silt fencing, turbidity screens, sand bags, silt curtain for in-water work, and/or lumber will be stored in a readily available location at the project site. A vacuum truck will be on site or on call to be employed as necessary.

## <sup>3</sup> Monitoring Procedures

Once drilling begins, the contractor will continuously monitor operations for evidence of an inadvertent release, such as abnormally high annular pressures or loss of circulation. The borehole pressure will be maintained as low as possible for a successful drilling operation, and will be continuously monitored by the contractor to identify abnormal changes, excessive increases, and loss of fluid volume or return flows.

The drilling fluid components will be continually tested and adjusted to adapt to the conditions of the subsurface. The contractor will monitor and document drilling fluid properties.

During all pilot drilling, reaming, and pullback operations, the contractor will visually inspect along the borehole alignment, including surface waters along the path, for evidence of a release. The monitor will have communication equipment, such as a radio or mobile phone, operational at all times during HDD activities, and will maintain direct communication with the HDD control cab. The drill rig operator will inform the alignment monitor in the case that, given the current mud pressures, volumes, and circulation, the operator believes there is an elevated risk for a frac-out event.

HDD operations during the crossing may be performed 24 hours per day to minimize the risk of HDD failure. Continuous operation maintains borehole integrity and minimizes the risk of borehole collapse, annular pressure spikes, and drill string or product pipe seizing. If operations continue before or after daylight hours, the worksite(s) will be well-lit using floodlights to allow for release detection, as well as a safe work environment.

## <sup>4</sup> Response Procedures

Should the results of the monitoring indicate that a frac-out is suspected, a monitor will be immediately dispatched to visually observe the area of the alignment. The contractor will take a combination of the following response procedures to minimize the volume of drilling fluid that is released and mitigate the severity of the potential frac-out:

- Decrease pump pressure
- Slow the advance rate
- Pull the drill string back
- Temporarily stop drilling operations and shut down mud pump
- Swab the borehole
- Adjust the drilling fluid parameters
- Make a slight change in the borepath alignment

If the frac-out is confirmed by an observed release to the surface or turbidity plume in the water, the contractor will attempt to advance the drill head past the known frac-out point. The contractor may determine that sealing a fissure is required.

In the event of a release, the contractor will assess the amount and location of the release, document the impact with notes and photographs, and then take corrective actions to contain the released fluid.

### ***Land Release***

If a land release is detected, the contractor will take immediate corrective action to contain the release and to prevent or minimize migration off site or into the water.

- The contractor will create a containment area by installing berms, silt fences, and/or straw bales to prevent drilling fluid or silt-laden water from flowing along the ground.
- The containment measures will be focused particularly between the location of the release and Santa Rosa Sound to prevent mud flow into the water.
- Construct pits and/or berms using hand tools and/or heavy equipment around the frac-out point to contain further releases onto the ground.
- Contractor will employ a vacuum truck as necessary to assist in the removal of the released fluid. Submersible pumps will be placed within the release area to capture material until the vacuum truck arrives.
- If the amount of an on-land release does not allow practical collection, the affected area will be diluted with fresh water and allowed to dry.
- If the release cannot be contained, drilling operations will be suspended until appropriate containment is in place. Small collection sumps may be constructed to pump the released fluid back into the mud processing system.
- After the HDD installation is complete, the frac-out area will be cleaned and all drilling mud disposed at an appropriate facility. All containment structures will be removed.

### ***Waterbody Release***

If release occurs within a waterbody, such as Santa Rosa Sound, the contractor will take immediate corrective action to contain the release and minimize the impact to marine life and human health & safety.

- In shallow water, the contractor may install temporary dams with sand bags to isolate the released fluid from migrating further into the waterbody. Contractor will employ a vacuum truck as necessary to assist in the removal of the released fluid.
- Wherever necessary, the contractor will create a containment area by installing a silt curtain around the area of turbidity.
- Silt curtains will be clearly marked to be visible to marine traffic, and to the extent possible will be placed or moved outside of high-traffic areas.
- Waterbody releases will be evaluated based on the extent and accessibility of the release area to determine the best method of cleanup. In some cases, recovery and cleanup of drilling fluid released into large bodies of water are not practical, as recovery measures have potentially greater impact to the environment than allowing the water-soluble drilling fluid to dissipate slowly.
- Whenever possible, the released fluid will be removed from the site and disposed at an appropriate facility. All containment structures will be removed.
- If the release cannot be contained, drilling operations will be suspended until appropriate containment is in place.

After successful containment and removal of the released material, operations will be able to continue (with the appropriate agencies' approval). All the activities associated with the frac-out response will be documented, and measures to prevent another release will be discussed.

## 5 Notification

In the event of an inadvertent release, the contractor will take immediate corrective action, as identified above, to contain the release and to minimize or prevent impacts. If Santa Rosa Sound or other sensitive areas are affected, within 24 hours the Florida Department of Environmental Protection will be notified of the release.

The following information will be provided:

- Date and time of inadvertent release
- Location(s) of release and proximity to sensitive feature
- Quantity and type of material released and amount of recovered materials
- Containment and cleanup measures that have been completed and that are planned

The Contractor will work with the respective agencies to identify and complete any additional containment or cleanup measures.

## 6 Florida Manatee Awareness

In the event of a frac-out, the Standard Manatee Conditions for In-Water Work (revision 2011) shall be followed for all in-water activity, and the Florida Fish and Wildlife Conservation Commission (FWC) shall be notified of the event immediately at [ImperiledSpecies@myfwc.com](mailto:ImperiledSpecies@myfwc.com), including the permit number, dates and status of the event. If a manatee comes within 10 feet of drilling mud, FWC shall be notified by immediately calling FWC's Hotline at 1-888-404-3922.

## 7 Abandonment

A borehole will need to be abandoned if a frac-out cannot be avoided, or if a frac-out has occurred that cannot be controlled and mitigation measures have been determined to not be effective. The borehole will be completely abandoned, grouted, and a new alignment determined. Any borehole abandonment locations will be documented and shown on as-built documents.

The following steps will be implemented during abandonment of the borehole:

- Determine the new alignment for the HDD crossing.
- Insert casing, as necessary to remove the pilot string.
- Pump a thick grout plug into the borehole to securely seal the abandoned borehole.



---

**DRAWINGS**

**(BOUND SEPARATELY)**

---



BID DOCUMENTS  
 For the construction of the  
**BROOKS BRIDGE**  
**WATER MAIN REPLACEMENT**  
**FOR THE**  
**OKALOOSA ISLAND**  
**WATER SUPPLY PROJECT**

INDEX OF DRAWINGS	
SHEET NO.	TITLE
G-01	COVER SHEET / INDEX OF DRAWINGS
G-02	GENERAL LEGEND AND NOTES
C-01	OVERALL SITE PLAN AND SURVEY CONTROL
C-02	WATER MAIN OVERALL PLAN AND PROFILE
C-03	WATER MAIN STA 0+00 TO 11+50 PLAN AND PROFILE
C-04	WATER MAIN STA 11+50 TO 24+00 PLAN AND PROFILE
C-05	STANDARD DETAILS

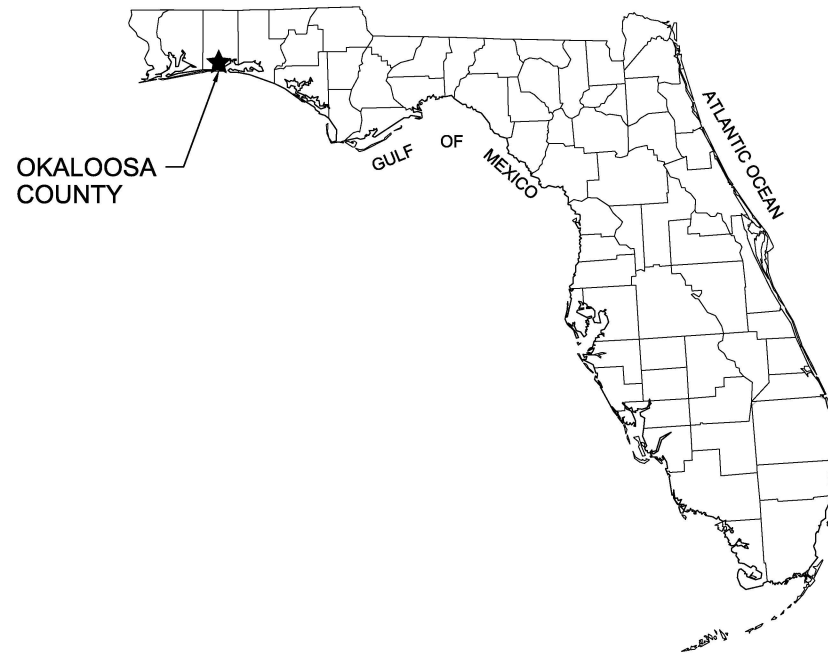

VICINITY MAP  
NTS



Prepared for  
**OKALOOSA COUNTY,**  
**FLORIDA**  
**Volume 2 of 2**  
**Drawings**



PROJECT LOCATION

LOCATION MAP  
NTS

For information regarding this project, contact:

Kevin Waddell, P.E. / CH2M HILL  
 25 W Cedar Street, Suite 350  
 Pensacola, FL 32502  
 Phone: 850-941-7279



Project No. 691267

AUGUST 2018

# WATER MAIN PLAN AND PROFILE LEGEND

---	EXISTING PROPERTY LINE
---	EXISTING RIGHT-OF-WAY LINE
---	EXISTING SHORELINE
---	EXISTING EDGE OF PAVEMENT
---	EXISTING BUILDING
---	EXISTING FENCE LINE
fm	EXISTING FORCE MAIN
w	EXISTING WATER MAIN
s	EXISTING SEWER MAIN
f	EXISTING FIBER OPTIC
gs	EXISTING GAS MAIN
---	EXISTING TREE LINE
---	EXISTING CONTOUR
x5.82	EXISTING SPOT ELEVATION
o <sup>op</sup>	EXISTING POWER POLE
---	EXISTING GUY WIRE
x	EXISTING WATER VALVE
o	EXISTING SEWER MANHOLE
o	EXISTING GAS VALVE
o <sup>t</sup>	EXISTING TELEPHONE BOX
o	EXISTING WATER METER
o <sup>p</sup>	EXISTING IRON PIPE
o	EXISTING PULL BOX
o	EXISTING LIGHT POLE
o	EXISTING TREE
o	EXISTING PINE TREE
o	EXISTING PALM TREE
o	STANDARD PENETRATION TEST BORINGS
---	PIPELINE WITH STATIONING
17+00	
---	PROPOSED PIPE LAYDOWN
//	SILT FENCE
---	WATTLE SEDIMENT CONTROL
o	SURVEY CONTROL POINT

# ABBREVIATIONS

@	AT
ABDN	ABANDON
AC	ASBESTOS CEMENT
ACQD	ACQUIRED
BLVD	BOULEVARD
BOT	BOTTOM
BTC	BURIED TELEPHONE CABLE
CI	CAST IRON
COMM	COMMUNICATIONS
CONC	CONCRETE
DI	DUCTILE IRON
DIA	DIAMETER
E	EAST
EAFB	EGLIN AIR FORCE BASE
ENG	ENGINEER
EW	EACH WAY
EL	ELEVATION
EOP	EDGE OF PAVEMENT
EXST	EXISTING
FDOT	FLORIDA DEPARTMENT OF TRANSPORTATION
G	GAS
HDD	HORIZONTAL DIRECTIONAL DRILL
HDPE	HIGH DENSITY POLYETHYLENE
HORIZ	HORIZONTAL
INV	INVERT
IP	IRON POST
LF	LINEAR FT
LT	LEFT
MH	MANHOLE
MJ	MECHANICAL JOINT
MAX	MAXIMUM
MIN	MINIMUM
N	NORTH
NO	NUMBER
NTS	NOT TO SCALE
OC	ON CENTER
OCWS	OKALOOSA COUNTY WATER AND SEWER DEPARTMENT
OD	OUTSIDE DIAMETER
PL	PROPERTY LINE
PP	POWER POLE
PVC	POLYVINYL CHLORIDE
RCP	REINFORCED CONCRETE PIPE
REQD	REQUIRED
RD	ROAD
RJ	RESTRAINED JOINT
RT	RIGHT
RR	RAILROAD
R/W	RIGHT OF WAY
S	SOUTH
SD	STORM DRAIN
SDR	STANDARD DIMENSION RATIO
SIM	SIMILAR
SPECD	SPECIFIED
STA	STATION
STOVL	SHORT TAKE-OFF AND VERTICAL LANDING PADS
TEL	TELEPHONE
TYP	TYPICAL
UGE	UNDERGROUND ELECTRICAL
VERT	VERTICAL
W	WATER
WM	WATER MAIN
WT	WEIGHT
W	WEST
W/	WITH

# GENERAL CONSTRUCTION NOTES

1. THE CONTRACTOR SHALL VERIFY THE LOCATION, DEPTH, SIZE, AND CONDITION OF ALL UTILITIES BEFORE BEGINNING CONSTRUCTION. ANY CONFLICTS OR CONCERNS SHALL BE BROUGHT TO THE ATTENTION OF THE ENGINEER IMMEDIATELY.
2. STATIONING SHOWN ON THE DRAWINGS THAT IS SCREENED BACK IS THE SURVEY STATIONING.
3. ALL WATER MAINS SHALL BE INSTALLED WITH A MINIMUM OF 36-INCHES OF COVER. ALL FITTINGS SHALL BE RESTRAINED AS SPEC'D.
4. THE DESIGN OF THE HDD WAS BASED ON THE SUBSURFACE INVESTIGATION CONDUCTED BY LARRY M. JACOBS ASSOCIATES, INC. DATED MAY 2017.
5. ALL FITTINGS SHALL BE DUCTILE IRON MECHANICAL JOINT IN CONFORMANCE TO AWWA C-110.
6. THE HORIZONTAL STATIONING SHOWN ON THE DRAWINGS DOES NOT TAKE INTO ACCOUNT FOR CHANGES IN VERTICAL ALIGNMENT.
7. SYMBOLS FOR THE LEGEND ARE USED THROUGHOUT THE DRAWINGS. ALL OF THE SYMBOLS ARE NOT NECESSARILY USED IN THE PROJECT.
8. CONTRACTOR IS RESPONSIBLE FOR IMPLEMENTATION AND MAINTAINING EROSION CONTROL MEASURES DURING CONSTRUCTION. EROSION CONTROL MEASURES SHOWN ON THE DRAWINGS ARE THE MINIMUM REQUIRED. CONTRACTOR TO IMPLEMENT ADDITIONAL MEASURES AS NECESSARY TO PREVENT EROSION AND SEDIMENT FROM LEAVING THE PROJECT AREA.
9. WHERE REFERENCE IS MADE TO FDOT INDEX 102, IT SHALL PERTAIN TO THE LATEST EDITION OF THE FLORIDA DEPARTMENT OF TRANSPORTATION'S STANDARD SPECIFICATIONS FOR ROAD AND BRIDGE CONSTRUCTION.
10. AMERICAN WATER WORKS ASSOCIATION MANUAL M31 DISTRIBUTION SYSTEM REQUIREMENTS FOR FIRE PROTECTION, NFPA 24, INSTALLATION OF PRIVATE FIRE SERVICE MAINS AND THEIR APPURTENANCES AND UFC 3-230-10A, DESIGN: WATER SUPPLY, WATER DISTRIBUTION TO THE REFERENCES FOR THE PROJECT IAW UFC 3-600-01 3-7.
11. TIDAL WATER LEVELS:  
MEAN HIGH WATER = 3.4  
MEAN LOW WATER = 2.9
12. CONSTRUCTION ACTIVITIES ARE TO COMPLY WITH NATIONAL MARINE FISHERIES SERVICES "PDC, FOR IN-WATER ACTIVITIES" DATED NOVEMBER 20, 2017. INCLUDED FOR COMPLIANCE ARE THE "SEA TURTLE AND SMALL TOOTH SAWFISH CONSTRUCTION CONDITIONS" DATED MARCH 23, 2006 AS WELL AS THE "STANDARD MANATEE CONDITIONS FOR IN-WATER WORK - APRIL 2013".
13. CONTRACTOR IS TO ABIDE BY THE FRAC-OUT CONTINGENCY PLAN DURING CONSTRUCTION. "HORIZONTAL DIRECTIONAL DRILLING CONTINGENCY AND FRAC-OUT RESPONSE PLAN."

# DETAIL AND SECTION DESIGNATION

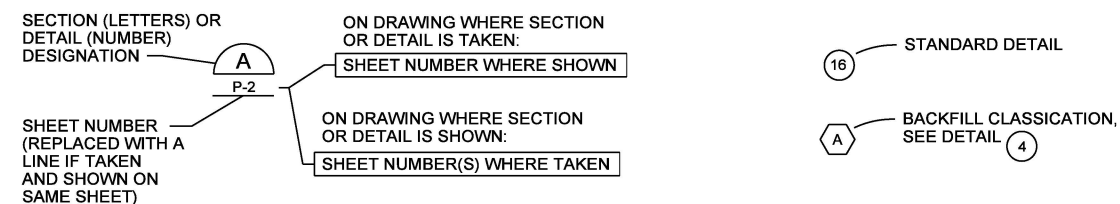

25 W CEDAR STREET, SUITE 350  
PENSACOLA, FL 32502  
KEVIN WADDELL PE 88025

BROOKS BRIDGE WATER MAIN REPLACEMENT  
FOR THE  
OKALOOSA ISLAND WATER SUPPLY PROJECT  
OKALOOSA COUNTY, FL

**ch2m**  
GENERAL  
LEGEND  
AND NOTES

VERIFY SCALE	
BAR IS ONE INCH ON ORIGINAL DRAWING.	
DATE	AUGUST 2018
PROJ	691267
DWG	G-02
SHEET	of

BID DOCUMENTS

**NOTES:**

- FUSED PIPE STAGING ALIGNMENT OPTION IS SHOWN. CONTRACTOR TO SUBMIT PROPOSED STAGING PLAN ALONG WITH TRAFFIC CONTROL PLAN. CONTRACTOR TO PROVIDE TRAFFIC CONTROL AND TEMPORARY ACCESS WHILE STAGING FOR FUSED PIPE. PROVIDE MEANS OF INGRESS AND EGRESS TO ALL RESIDENCES AND BUSINESSES DURING CONSTRUCTION.
- SEE SHEET C-03 AND C-04 FOR LIMITS OF WORK AND CONTRACTOR RESPONSIBILITY.
- SEE GENERAL CONSTRUCTION NOTES ON SHEET G-02.

**CONTROL POINTS**

RSM CONTROL POINT #104158  
 NAIL & DISC LS #5791 (SET)  
 NORTHING: 514938.5940'  
 EASTING: 1306262.4610'  
 ELEVATION: 2.91'

RSM CONTROL POINT #104160  
 CAPPED IRON ROD LS #5791 (SET)  
 NORTHING: 515006.2630'  
 EASTING: 1306251.6790'  
 ELEVATION: 3.27'

RSM CONTROL POINT #104156  
 CAPPED IRON ROD LS #5791 (SET)  
 NORTHING: 514939.1590'  
 EASTING: 1306118.4560'  
 ELEVATION: 3.13'

RSM CONTROL POINT #104213  
 CAPPED IRON ROD LS #5791 (SET)  
 NORTHING: 515825.0280'  
 EASTING: 1305877.0100'  
 ELEVATION: 3.60'

RSM CONTROL POINT #104211  
 NAIL & DISC LS #5791 (SET)  
 NORTHING: 515761.8940'  
 EASTING: 1305794.3380'  
 ELEVATION: 3.63'

RSM CONTROL POINT #104215  
 CAPPED IRON ROD LS #5791 (SET)  
 NORTHING: 515886.3240'  
 EASTING: 1305800.4890'  
 ELEVATION: 4.06'

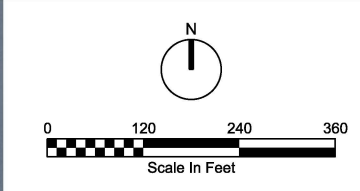

25 W CEDAR STREET, SUITE 360 PENSACOLA, FL 32502 KEVIN WADDELL PE 83025		FOR THE BROOKS BRIDGE WATER MAIN REPLACEMENT OKALOOSA ISLAND WATER SUPPLY PROJECT OKALOOSA COUNTY, FL		J. KLAUS	
ch2m.		CIVIL		M. STICKLEY	
OVERALL SITE PLAN AND SURVEY CONTROL		APVD		BY	
VERIFY SCALE BAR IS ONE INCH ON ORIGINAL DRAWING.		DR		APVD	
DATE AUGUST 2018		CHK		BY	
PROJ 691267		REVISION		BY	
DWG C-01		NO.		DATE	
SHEET of		DSGN		NO.	
PLOT DATE: 8/9/2018		PLOT TIME: 8:39:08 AM		PLOT DATE: 8/9/2018	
PLOT TIME: 8:39:08 AM		PLOT DATE: 8/9/2018		PLOT TIME: 8:39:08 AM	

REUSE OF DOCUMENTS: THIS DOCUMENT, AND THE IDEAS AND DESIGNS INCORPORATED HEREIN, AS AN INSTRUMENT OF PROFESSIONAL SERVICE, IS THE PROPERTY OF CH2M HILL AND IS NOT TO BE USED, IN WHOLE OR IN PART, FOR ANY OTHER PROJECT WITHOUT THE WRITTEN AUTHORIZATION OF CH2M HILL. © CH2M HILL 2018. ALL RIGHTS RESERVED.



- NOTES:**
1. PIPE MUST BE FULL OF WATER DURING INSTALLATION.
  2. SEE SHEETS C-03 AND C-04 FOR LIMITS OF WORK AND CONTRACTOR RESPONSIBILITY.
  3. SEE GENERAL CONSTRUCTION NOTES ON SHEET G-02.

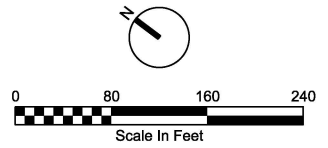

25 W CEDAR STREET, SUITE 350 PENSACOLA, FL 32502 KEVIN WADDELL PE 83025		FOR THE OKALOOSA ISLAND WATER SUPPLY PROJECT OKALOOSA COUNTY, FL	
NO.	DATE	DR	CHK
		K WADDELL	C CHILDRESS
			M STICKLEY
			J KLAUS
			BY APVD
			APVD

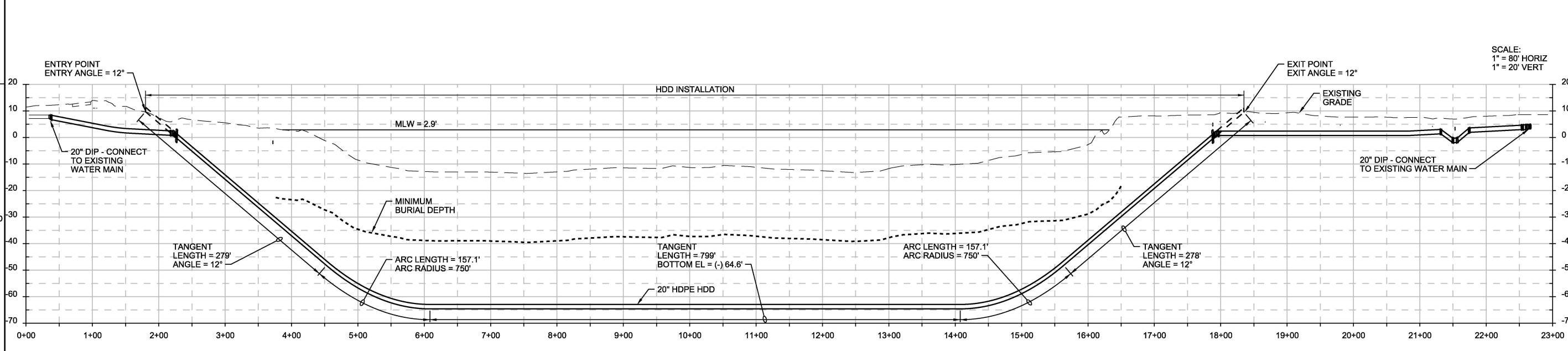

**ch2m**

CIVIL  
**WATER MAIN  
OVERALL PLAN AND PROFILE**

VERIFY SCALE  
BAR IS ONE INCH ON ORIGINAL DRAWING.

DATE	AUGUST 2018
PROJ	691267
DWG	C-02
SHEET	of

REUSE OF DOCUMENTS: THIS DOCUMENT, AND THE IDEAS AND DESIGNS INCORPORATED HEREIN, AS AN INSTRUMENT OF PROFESSIONAL SERVICE, IS THE PROPERTY OF CH2M HILL AND IS NOT TO BE USED, IN WHOLE OR IN PART, FOR ANY OTHER PROJECT WITHOUT THE WRITTEN AUTHORIZATION OF CH2M HILL. © CH2M HILL 2018. ALL RIGHTS RESERVED.

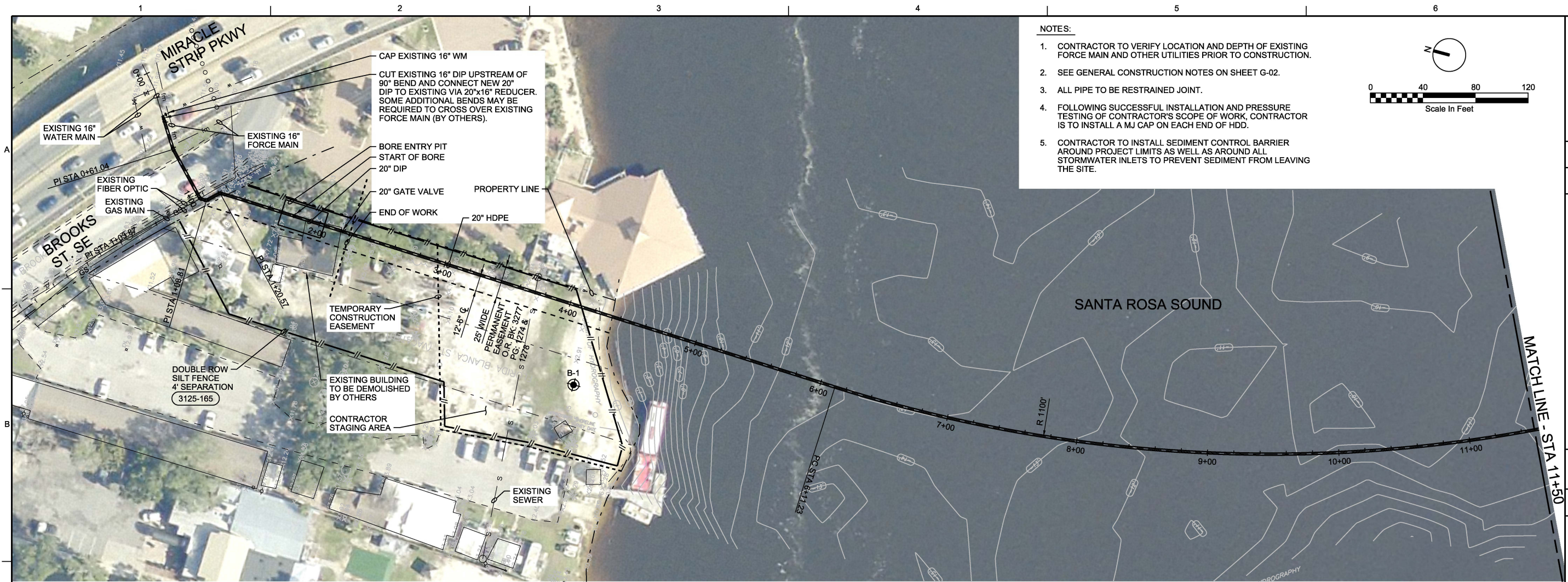

- NOTES:**
- CONTRACTOR TO VERIFY LOCATION AND DEPTH OF EXISTING FORCE MAIN AND OTHER UTILITIES PRIOR TO CONSTRUCTION.
  - SEE GENERAL CONSTRUCTION NOTES ON SHEET G-02.
  - ALL PIPE TO BE RESTRAINED JOINT.
  - FOLLOWING SUCCESSFUL INSTALLATION AND PRESSURE TESTING OF CONTRACTOR'S SCOPE OF WORK, CONTRACTOR IS TO INSTALL A MJ CAP ON EACH END OF HDD.
  - CONTRACTOR TO INSTALL SEDIMENT CONTROL BARRIER AROUND PROJECT LIMITS AS WELL AS AROUND ALL STORMWATER INLETS TO PREVENT SEDIMENT FROM LEAVING THE SITE.

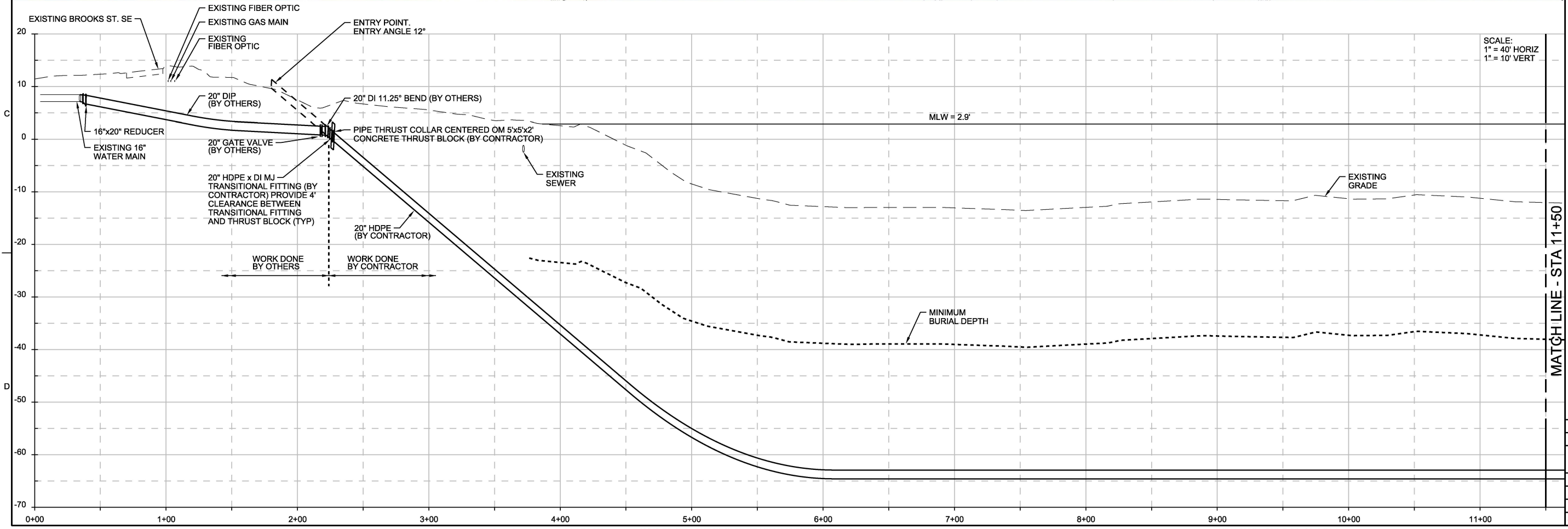
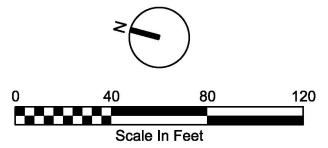

NO.	DATE	DR	CHK	REVISION	BY	APVD

25 W CEDAR STREET, SUITE 360  
PENSACOLA, FL 32502  
KEVIN WADDELL PE 83025

BROOKS BRIDGE WATER MAIN REPLACEMENT  
FOR THE  
OKALOOSA ISLAND WATER SUPPLY PROJECT  
OKALOOSA COUNTY, FL

**ch2m**

CIVIL  
**WATER MAIN  
STA 0+00 TO 11+50  
PLAN AND PROFILE**

VERIFY SCALE BAR IS ONE INCH ON ORIGINAL DRAWING.
DATE AUGUST 2018
PROJ 691267
DWG C-03
SHEET of

BID DOCUMENTS

©CH2M HILL 2018. ALL RIGHTS RESERVED.

**NOTES:**

1. CONTRACTOR TO VERIFY LOCATION AND DEPTH OF EXISTING FORCE MAIN AND OTHER UTILITIES PRIOR TO CONSTRUCTION.
2. CONTRACTOR TO MONITOR THE AREA AROUND BORING B-2 FOR FRAC-OUT.
3. SEE GENERAL CONSTRUCTION NOTES ON SHEET G-02.
4. ALL PIPE TO BE RESTRAINED JOINT.
5. FOLLOWING SUCCESSFUL INSTALLATION AND PRESSURE TESTING OF CONTRACTOR'S SCOPE OF WORK, CONTRACTOR IS TO INSTALL A MJ CAP ON EACH END OF HDD FOLLOWING THE TRANSITIONAL FITTING.
6. CONTRACTOR TO INSTALL SEDIMENT CONTROL BARRIER AROUND PROJECT LIMITS AS WELL AS AROUND ALL STORMWATER INLETS TO PREVENT SEDIMENT FROM LEAVING THE SITE.

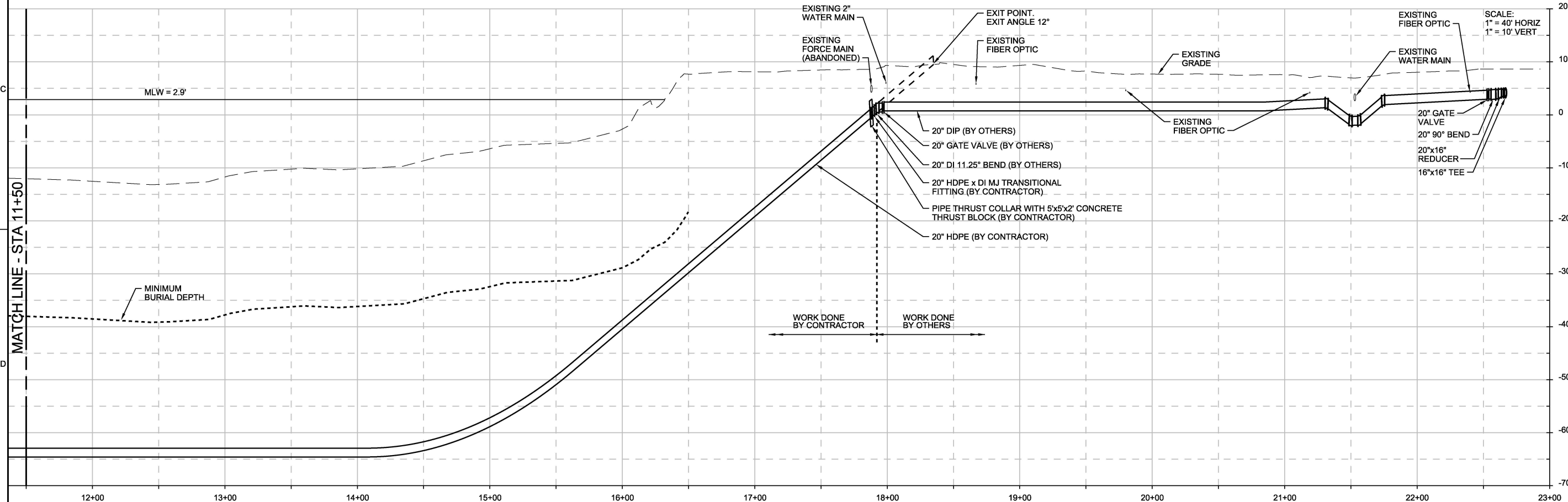
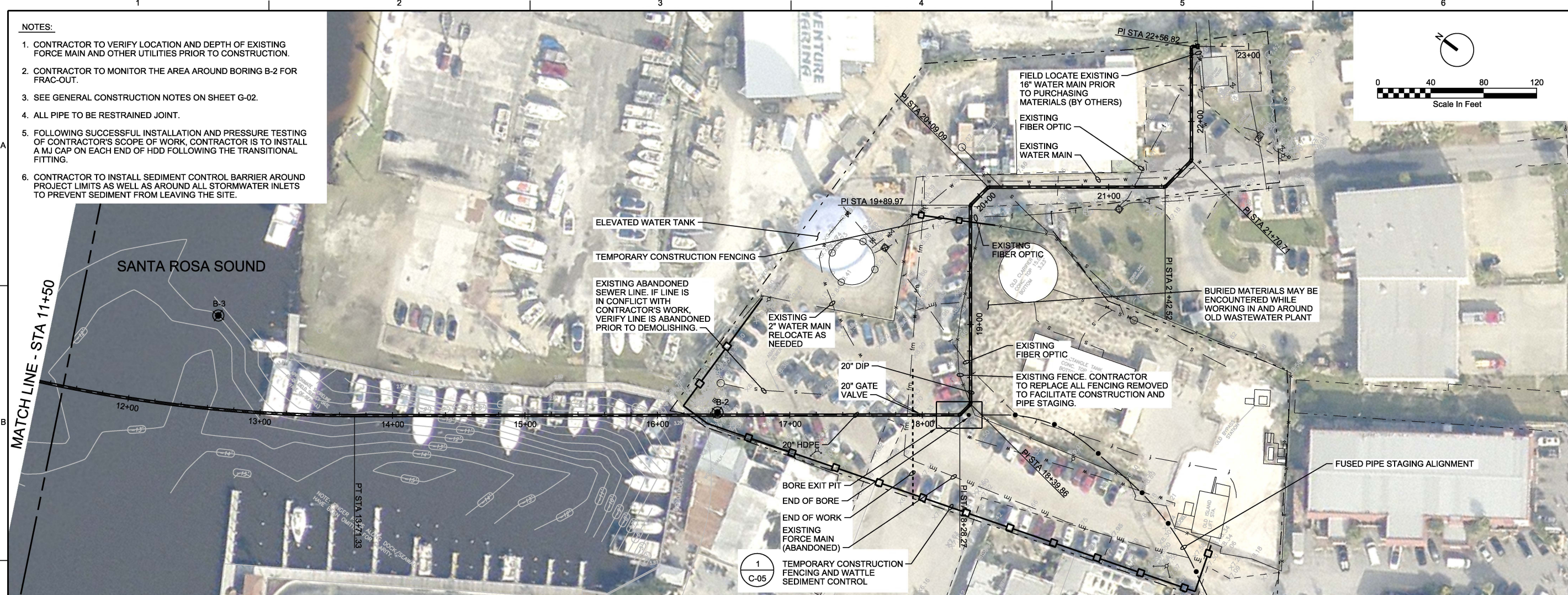

25 W CEDAR STREET, SUITE 350 PENSACOLA, FL 32502 KEVIN WADDELL PE 83025		J. KLAUS	
BROOKS BRIDGE WATER MAIN REPLACEMENT FOR THE OKALOOSA ISLAND WATER SUPPLY PROJECT OKALOOSA COUNTY, FL		M. STICKLEY	
CIVIL		C. CHILDRESS	
WATER MAIN STA 11+50 TO 24+00 PLAN AND PROFILE		K. WADDELL	
VERIFY SCALE BAR IS ONE INCH ON ORIGINAL DRAWING.		DR	
DATE AUGUST 2018		NO. DATE	
PROJ 691267		REVISION	
DWG C-04		CHK	
SHEET of		APVD	
FILENAME: 005-C-04_691267.dgn		BY APVD	
PLOT DATE: 8/9/2018		J. KLAUS	
PLOT TIME: 8:39:24 AM		© CH2M HILL 2018. ALL RIGHTS RESERVED.	

BID DOCUMENTS



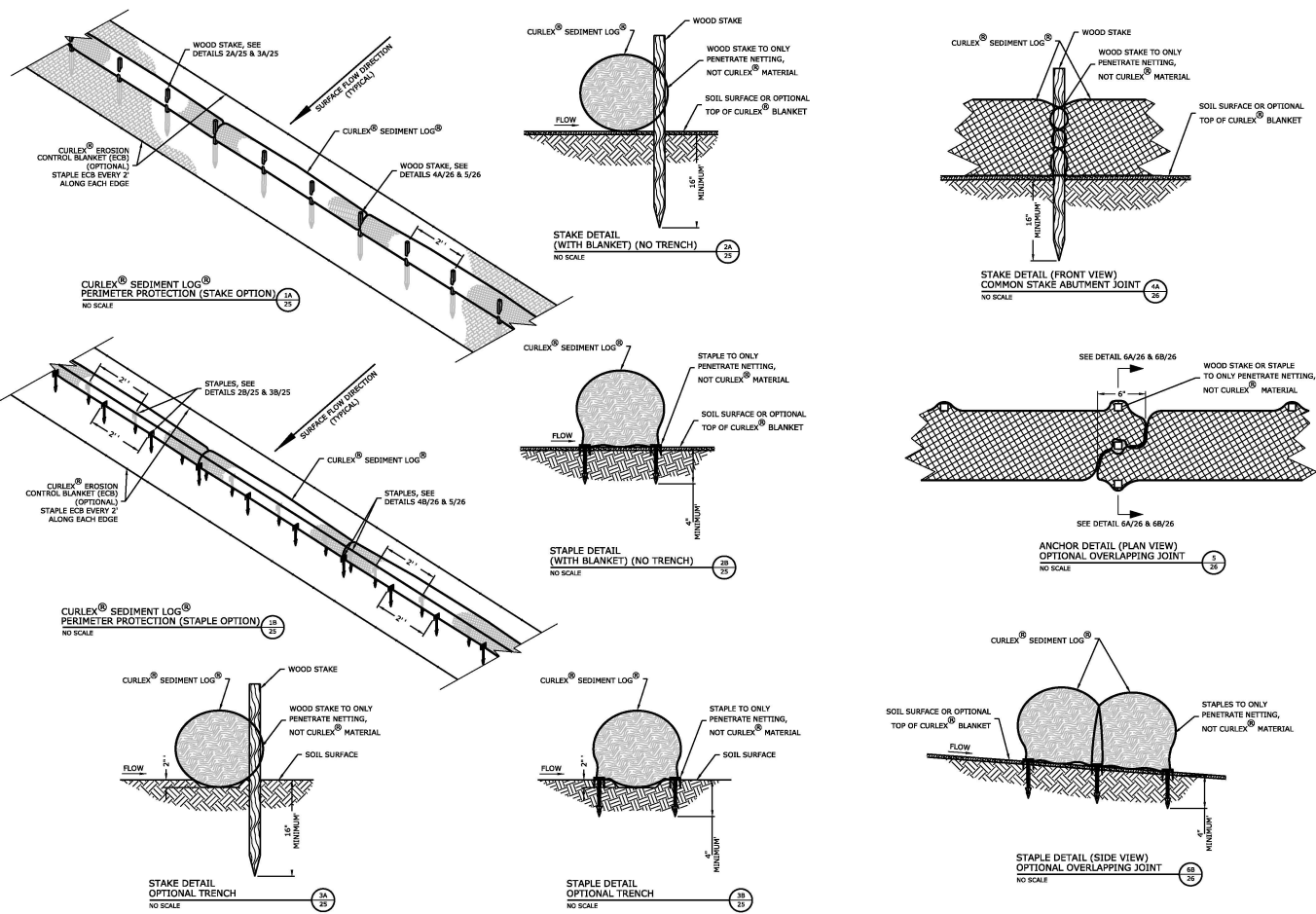

**1** WATTLE SEDIMENT CONTROL  
NTS

- NOTES:
1. RECOMMENDED STAPLES ARE E-STAPLE®, 1 IN X 6 IN, U-SHAPED, 11 GAUGE WIRE, OR 2 IN X 8 IN, U-SHAPED, 8 GAUGE WIRE.
  2. STAPLES SHALL BE INSTALLED 24 IN APART ON EACH SIDE OF THE CURLEX® SEDIMENT LOG®. THE TWO ROWS OF STAPLES SHALL BE STAGGERED BY 12 IN ALONG THE LENGTH OF THE CURLEX® SEDIMENT LOG®. INSTALLATION OF ONE CURLEX® SEDIMENT LOG® SHALL INCLUDE ONE STAPLE ON EACH END OF THE PRODUCT. ALL STAPLES SHALL BE FULLY INSERTED INTO THE SUBGRADE BELOW THE CURLEX® SEDIMENT LOG®.
  3. JOIN TWO CURLEX® SEDIMENT LOGS BY PLACING STAPLES THROUGH THE NETTING OF BOTH LOGS ON BOTH SIDES OF THE PRODUCTS.
  4. ANCHORING WITH STAPLES IS ONLY APPLICABLE FOR 6 IN AND 9 IN CURLEX® SEDIMENT LOGS AND SHALL NOT BE USED IN CHANNELIZED FLOW APPLICATIONS.
  5. STAPLES MAY BE USED IN CONJUNCTION WITH STAPLES FOR ADDITIONAL ANCHORING OF 6 IN AND 9 IN CURLEX® SEDIMENT LOGS, AS DEEMED NECESSARY BY THE ENGINEER.
  6. RECOMMENDED WOODEN STAKES ARE 1 1/4" X 1 1/2" X 30" FOR 6", 9", AND 12" SEDIMENT LOGS.
  7. RECOMMENDED WOODEN STAKES ARE 1 1/4" X 1 1/2" X 48" FOR 20" SEDIMENT LOGS.

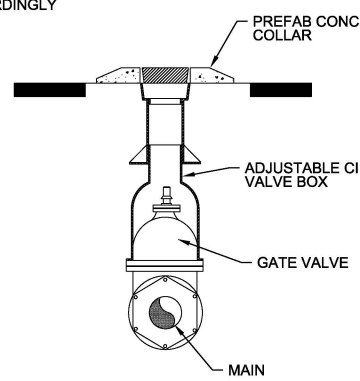

**3** TYPICAL GATE VALVE AND BOX DETAIL  
NTS

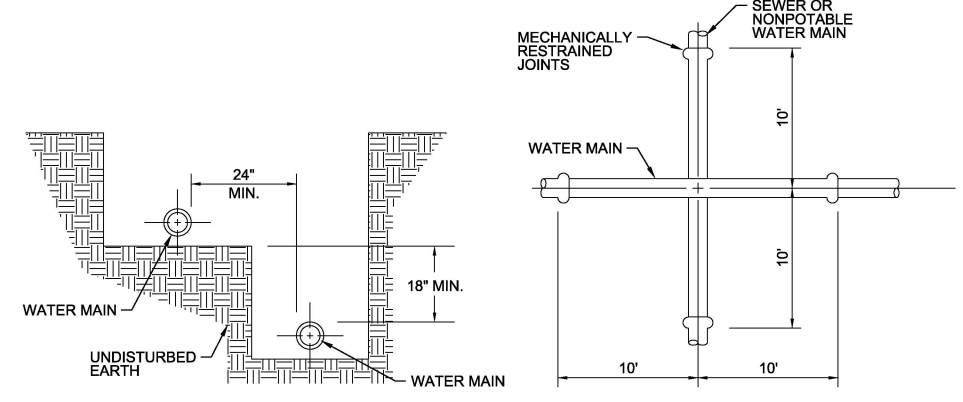

- NOTES:
1. IF THE REQUIRED 18 INCH VERTICAL SEPARATION CANNOT BE OBTAINED BETWEEN A WATER MAIN AND A SEWER MAIN THEN THE SEWER OR NONPOTABLE WATER MAIN PORTION SHALL BE 20 FEET OF DUCTILE IRON PIPE CENTERED AT THE CROSSING AND THE WATER MAIN SHALL BE 20 FEET OF DUCTILE IRON PIPE WITH MECHANICALLY RESTRAINED JOINTS.

**4** SEWER / WATER SEPARATION DETAIL  
NTS

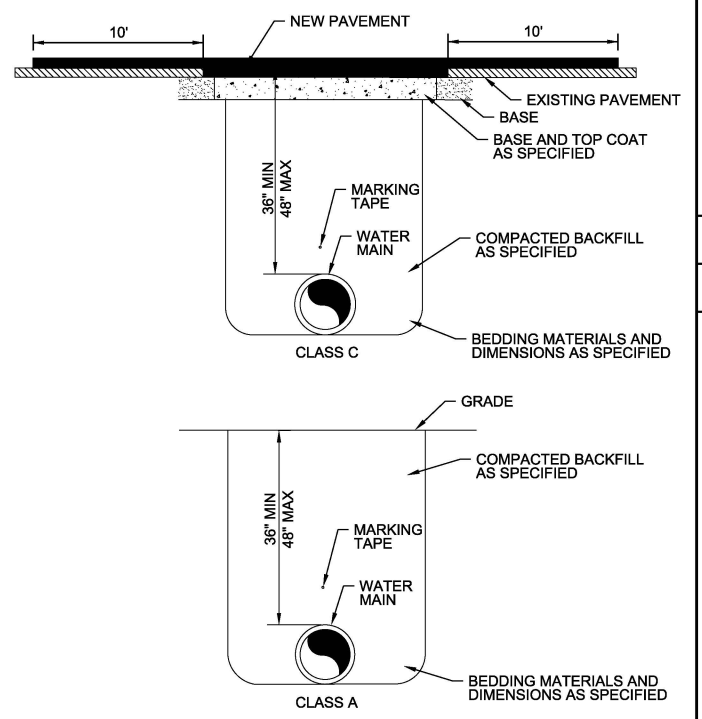

NOTE:  
ALL BACKFILL AND PAVING TO BE IN ACCORDANCE WITH CURRENT EDITION OF STATE HIGHWAY SPECIFICATIONS.

**2** TYPICAL WATER MAIN INSTALLATION  
NTS

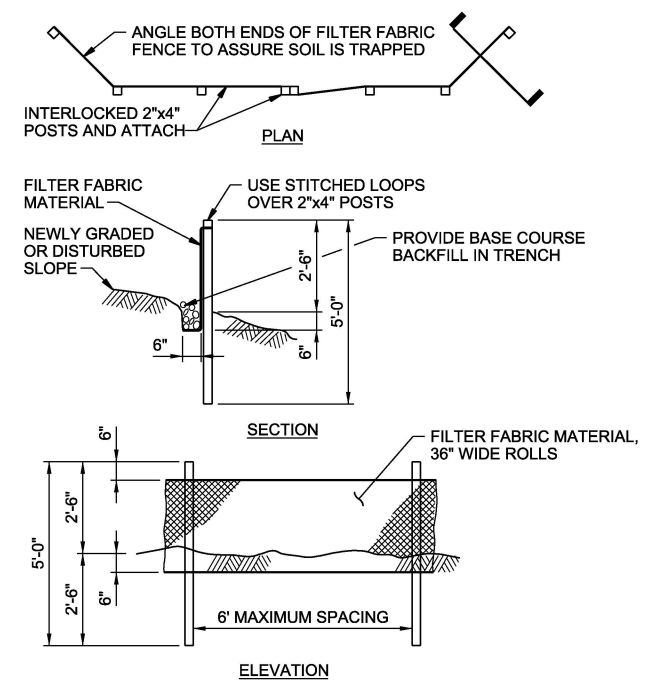

- NOTES:
1. BURY BOTTOM OF FILTER FABRIC 6" VERTICALLY BELOW FINISHED GRADE.
  2. 2"x4" DOUGLAS FIR OR STEEL FENCE POSTS.
  3. STITCHED LOOPS TO BE INSTALLED DOWNHILL SIDE OF SLOPE.
  4. COMPACT ALL AREAS OF FILTER FABRIC TRENCH.

**SILT FENCE**  
NTS

NO.	DATE	DR	REVISION	CHK	APVD	BY	APVD
		K WADDELL		C CHILDRESS	M STICKLEY		J KLAUS

25 W CEDAR STREET, SUITE 350  
PENSACOLA, FL 32502  
KEVIN WADDELL PE 88025

BROOKS BRIDGE WATER MAIN REPLACEMENT  
FOR THE  
OKALOOSA ISLAND WATER SUPPLY PROJECT  
OKALOOSA COUNTY, FL

**ch2m**  
CIVIL  
STANDARD DETAILS

VERIFY SCALE  
BAR IS ONE INCH ON ORIGINAL DRAWING.  
0 1"

DATE AUGUST 2018  
PROJ 691267  
DWG C-05  
SHEET of

3125-165