

BID DOCUMENTS
for
VPS FUEL FARM FALL PROTECTION
ITB AP 12-20

Prepared for:



**Okaloosa County Board
of County Commissioners**

Prepared by:



AVCON, INC.

320 Bayshore Dr, Ste A
Niceville, Florida 32578
Phone: 850.678.0050

AVCON Project Number: 2019.0050.01

BID DOCUMENTS

October 2019

TABLE OF CONTENTS

FRONT END DOCUMENTS

Notice to Bidders..... NTB- 1
 Instructions to Contractors ITC- 1
 Okaloosa County Standard Clauses..... BOC- 1

BID DOCUMENTS

Bid Form BF- 1
 Bid Schedule BS- 1
 Bid AffidavitBA- 1
 Bid BondBB- 1
 Contractor’s Qualification Questionnaire . CQQ- 1
 Form of Noncollusion Affidavit NCA- 1
 Certification of Non-Segregated Facilities...NSF- 1
 Sworn Statement Under Section 287.133 (3) (a),
 Florida Statutes, on Public Entity Crimes SSPEC- 1
 Certificate as to Corporate PrincipalCCP- 1
 Certified Copy of Resolution of Board of
 Directors RBD- 1
 Conflict of Interest Disclosure Form..... OC- 1
 Drug-Free Workplace Certification OC- 2
 Certification of Contractor Regarding Trench
 Safety OC- 3
 Indemnification and Hold Harmless..... OC- 4
 Insurance Compliance OC- 5
 Affidavit – Worker’s Compensation OC- 6
 Recycled Content Form OC- 7
 Disadvantaged Business Enterprise OC- 8-11
 DBE Certificate of Compliance Form OC- 12
 Performance of Work By
 Subcontractors PWSC- 1
 E-Verify Compliance CertificationEVCC- 1
 Cone of Silence CS- 1
 Buy American Certificate..... BAC- 1
 Lobbying – 31 USC 1352 LF- 1
 Equal Employment Opportunity Report
 Statement..... EEOR- 1

Standard Form of Agreement SFA- 1
 Performance Bond PFBND- 1
 Payment Bond..... PYBND- 1
 Contractor’s Release of Liens..... CONRELNS- 1
 Advertisement of Completion AFC- 1
 Standard Additional Contract Clauses SACC-1

GENERAL CONDITIONSGC-1

CONTRACT FORMS

FRONT END DOCUMENTS



BID DOCUMENTS
VPS FUEL FARM FALL PROTECTION

**NOTICE TO RESPONDENTS
ITB AP 12-20**

Notice is hereby given that the Board of County Commissioners of Okaloosa County, FL, will accept sealed bids until **3:00 p.m. (CST) January 29, 2020**, for **VPS Fuel Farm Fall Protection for Destin-Fort Walton Beach Airport**.

The VPS Fuel Farm Fall Protection project generally consists of fabricating and installing catwalk systems over eight existing fuel tanks to access ports and manways on top of the tanks.

Interested respondents desiring consideration shall provide one (1) original and two (2) copies (total of 3) of their Invitation to Bids (ITB) response with the requested quotes. Submissions shall be portrait orientation, unbound, and 8 ½" x 11" where practical.

All originals must have original signatures in blue ink. Bid documents are available for download by accessing the Okaloosa County website at <http://www.myokaloosa.com/purchasing/home> then accessing the link "View Current Solicitations & Public Notices" or by accessing the Florida Purchasing Group website at <http://www.floridabidsystem.com/Bids/ViewOpenSolicitations.asp>

At **3:00 p.m. (CST) on January 29, 2020**, all bids will be opened and read aloud. All bids must be in sealed envelopes reflecting on the outside thereof the Respondent's name and "**VPS Fuel Farm Fall Protection for Destin-Fort Walton Beach Airport**". The County will consider all bids properly submitted at its scheduled bid opening in the **Okaloosa County Courthouse** located at 101 E. James Lee Boulevard, Room 282, Crestview, FL 32536. If delivering on the bid opening day, delivery must be in person to 101 E. James Lee Boulevard, Room 282, Crestview, FL 32536.

****NOTE: MUST RING DOORBELL TO GAIN ENTRANCE INTO ROOM 282. THE CLERK WILL COME ACCEPT YOUR PACKAGE OR SHOW YOU TO THE CONFERENCE ROOM FOR THE SCHEDULED BID OPENING** THE NEW CRESTVIEW COURTHOUSE HAS SECURITY AT ENTRY POINT-PLEASE ALLOW FOR TIME TO GET THROUGH SECURITY WHEN ARRIVING FOR THE BID OPENING.**

NOTE: Crestview, FL is not a next day guaranteed delivery location by most delivery services. Respondents using mail or delivery services assume all risks of late or non-delivery.

A **non-mandatory** Pre-Bid Conference will be conducted at the Destin-Fort Walton Beach Airport, Conference Room No. 1, 1701 State Road 85 N., Eglin AFB, Florida 32542, at January 9, 2020 at 11 a.m. (C.S.T.) The last day for questions is on January 15, 2020 at 3:00 p.m. (C.S.T.). The respondent written questions may be sent to the Purchasing Department, Attn: Jesica Darr at jdarr@myokaloosa.com. The purchasing department will release an Addendum(s), as deemed necessary by the County, in response to written questions received no later than seven (7) business days prior to the Bid Opening date. Oral statements may not be relied upon and will not be binding or legally effective.

Any Respondent failing to mark outside of the envelope as set forth herein may not be entitled to have their bid considered.

All bids shall be addressed as follows:

VPS Fuel Farm Fall Protection for Destin-Fort Walton Beach Airport

Okaloosa County Courthouse
101 E. James Lee Boulevard Room 282
Crestview, FL 32536
ITB AP 12-20

Jeff Hyde
Purchasing Manager

Date

OKALOOSA COUNTY
BOARD OF COUNTY COMMISSIONERS

Chairman

INSTRUCTIONS TO CONTRACTORS

PROJECT IDENTIFICATION:

a) Project Title:

VPS FUEL FARM FALL PROTECTION

b) Owner:

OKALOOSA COUNTY BOARD OF COUNTY COMMISSIONERS

c) Engineer:

AVCON, INC.

INDEX

<u>Item</u>	<u>Para.</u>	<u>Page</u>
Availability of Lands for Work	5	ITC-4
Award of Contract	17	ITC-8
Bid Form	11	ITC-6
Bid Security	7	ITC-5
Bids to Remain Subject to Acceptance	15	ITC-7
Contract Times	8	ITC-5
Copies of Project Documents	2	ITC-2
Defined Terms	1	ITC-2
Disqualification of Contractors	16	ITC-7
Examination of Contract Documents and Site	4	ITC-2
Interpretations and Addenda	6	ITC-4
Modification and Withdrawal of Bids	13	ITC-7
Opening of Bids	14	ITC-7
Pre-Proposal Conference	18	ITC-8
Qualification of Contractors	3	ITC-2
Sales and Use Taxes	19	ITC-9
Subcontractors, Suppliers, and Others	10	ITC-5
Submission of Bids	12	ITC-7
Substitute or "Or-Equal" Items	9	ITC-5

1. Defined Terms.

Terms used in the Instructions to Contractors that are defined in the Standard General Conditions of the Project Manual have the meanings assigned to them in the General Conditions.

Certain additional terms used in the Instruction to Contractors have the meanings indicated below which are applicable to both the singular and plural thereof.

- 1.1 Contractor – one who submits a Bid directly to Owner as distinct from sub-contractor, who submits a bid to a Contractor.
- 1.2 Issuing Office – the office from which the Project Documents are to be issued and where the bid procedures are to be administered.
- 1.3 Successful Contractor – the lowest, responsible and responsive Contractor to whom Owner (on the basis of Owner's evaluation as hereinafter provided) makes and award.

2. Copies of Project Documents.

- 2.1 Complete sets of the Project Documents in the number and for the sum, if any, stated in the Advertisement or Notice to Contractors may be obtained from the Issuing Office.
- 2.2 Complete sets of Project Documents must be used in preparing Bids; neither Owner nor Engineer assume any responsibility for errors or misinterpretations resulting from the use of incomplete sets of Project Documents.
- 2.3 Owner and Engineer in making copies of Project Documents available on the above terms do so only for the purpose of obtaining Bids for the Work and do not confer a license or grant for any other use.

3. Qualifications of Contractors.

To demonstrate qualifications to perform the Work, each Contractor must submit within two (2) business days after Bid opening upon Owner's request detailed written evidence such as financial data, previous experience, present commitments and other such data as may be called for below. Each Bid must contain evidence of Contractors qualification to do business in the state where the Project is located or covenant to obtain such qualification prior to award of the contract.

4. Examination of Documents and Site.

- 4.1 It is the responsibility of each contractor before submitting a Bid:
 - 4.1.1 To examine thoroughly these documents and other related data identified (including "technical data" referred to below);
 - 4.1.2 To visit the site to become familiar with and satisfy Contractor as to the general, local and site conditions that may affect cost, progress, performance, or furnishing of the Work;

- 4.1.3 To consider federal, state, and local Laws and Regulations that may affect cost, progress, performance or furnishing of the Work;
 - 4.1.4 To study and carefully correlate Contractors knowledge and observations with these Project Documents and such other related data; and
 - 4.1.5 To promptly notify Engineer of all conflicts, errors, ambiguities or discrepancies which Contractor has discovered in or between these Project Documents and such other related documents.
 - 4.2 Reference is made to the Supplementary Conditions for identification of:
 - 4.2.1 Those reports of explorations and tests of subsurface conditions at or contiguous to the site which have been utilized by Engineer in preparation of these Project Documents. Contractor may rely upon the general accuracy of the "technical data" contained in such reports but not upon other data, interpretations, opinions or information contained in such reports or otherwise relating to the subsurface conditions at the site, nor upon the completeness thereof for the purposes of the bid or construction.
 - 4.2.2 Those drawings of physical conditions in or relating to existing surface and subsurface structures (except Underground Facilities) which are at or contiguous to the site that have been utilized by Engineer in preparation of these Project Documents. Contractor may rely upon the general accuracy of the "technical data" contained in such drawings but not upon other data, interpretations, opinions, or information shown or indicated in such drawings or otherwise relating to such structures, nor upon the completeness thereof for the purposes of the bid or construction.
- Copies of such reports and drawings will be made available by Owner to any Contractor on request. Those reports and drawings are not part of the Project Documents, but the "technical data" contained therein upon which Contractor is entitled to rely as provided in Paragraph 4.2 of the General Conditions and has been identified and established in Article 4 of the Supplementary Conditions. Contractor is responsible for any interpretation or conclusion drawn from any "technical data" or any such data, interpretations, opinions, or information.
- 4.3 Information and data shown or indicated in these Project Documents with respect to existing Underground Facilities at or contiguous to the site is based upon information and data furnished to Owner and Engineer by Owners of such Underground Facilities or others, and the Owner and Engineer do not assume responsibility for the accuracy or completeness thereof unless it is expressly provided otherwise in the Supplementary Conditions.
 - 4.4 Provisions concerning responsibilities for the adequacy of data furnished to prospective Contractors with respect to subsurface conditions, other physical conditions and Underground Facilities, and possible changes in these Project Documents due to differing or unanticipated conditions appear in Paragraphs 4.2 and 4.3 of the General Conditions.
 - 4.5 Before submitting a Bid each Contractor will be responsible to obtain such additional or supplementary examinations, investigations, explorations, tests, studies, and data concerning conditions (surface, subsurface, and Underground Facilities) at or contiguous to the site or otherwise, which may affect cost, progress, performance or furnishing of the Work or which

relate to any aspect of the means, methods, techniques, sequences or procedures of construction to be employed by the Contractor and safety precautions and programs incident thereto or performing and furnishing the Work in accordance with the time, price, and other terms and conditions of the Contact Documents.

- 4.6 On request, Owner will provide each Contractor access to the site to conduct such examinations, investigations, explorations, tests, and studies as each Contractor deems necessary for submission of a Bid. Contractor must fill all holes and clean up and restore the site to its former conditions upon completion of such explorations, investigations, tests, and studies.
- 4.7 Reference is made to the Supplementary Conditions for the identification of the general nature of work that is to be performed at the site by Owner or others (such as utilities and other prime contractors) that relates to the work for which a Bid is to be submitted. On request, Owner will provide to each Contractor for examination access to or copies of appropriate documents (other than portions thereof related to price) for such work.
- 4.8 The submission of a Bid will constitute an incontrovertible representation by Contractor that Contractor has complied with every requirement of this Article 4, that without exception of the Bid is premised upon performing and furnishing the Work required by these Project Documents and applying the specific means, methods, techniques, sequences, or procedures for construction (if any) that may be shown or indicated or expressly required by these Project Documents, the Contractor has given Engineer written notice of all conflicts, errors, ambiguities and discrepancies that Contractor has discovered in these Project Documents are generally sufficient to indicate and convey understanding of all terms and conditions for performing and furnishing the Work.
- 4.9 The provisions of 1-4.1 through 4.8, inclusive, do not apply to Asbestos, Polychlorinated biphenyls (PCBs), Petroleum, Hazardous Waste, or Radioactive Material covered by Paragraph 4.5 of the General Conditions.

5. Availability of Lands for Work, Etc.

The lands upon which the Work is to be performed, rights-of-way and easements for access thereto and other lands designated for use by the successful Contractor in performing the Work are identified in these Project Documents. All additional land and access thereto required for temporary construction facilities, construction equipment, or storage of materials and equipment to be incorporated in the Work are to be obtained and paid for by the Successful Contractor. Easements for permanent structures or permanent changes in existing facilities are to be obtained and paid for by Owner unless otherwise provided in these Project Documents.

6. Interpretations and Addenda.

- 6.1 All questions about the meaning or intent of these Project Documents are to be directed to Engineer. Interpretations or clarifications considered necessary by Engineer in response to such questions will be issued by Addenda mailed, faxed or delivered to all parties recorded by Engineer as having received the Project Documents. Questions received less than ten (10) days prior to the date for opening of Bids may not be answered. Only questions answered by formal

written Addenda will be binding. Oral and other interpretations or clarifications will be without legal effect.

- 6.2 Addenda may also be issued to modify these Project Documents as deemed advisable by Owner or Engineer.

7. Bid Security.

- 7.1 Each Bid must be accompanied by Bid security made payable to Owner in an amount of five percent (5%) of Contractors maximum Bid Price in the form of a certified or bank check or a Bid Bond on form attached, issued by a surety meeting the requirements of Paragraph 5.1 of the General Conditions.

- 7.2 The Bid security of Successful Contractor will be retained until such Contractor has executed the Agreement, furnished the required contract security, and met the other conditions of the Notice of Award, whereupon the Bid security will be returned. If the Successful Contractor fails to execute and deliver the Agreement and furnishes the required contract security within fifteen days after the Notice of Award, Owner may annul the Notice of Award and the Bid security of that Contractor will be forfeited. The Contractor security of other Contractors whom Owner believes to have a reasonable chance of receiving the award may be retained by Owner until the earlier of:

the seventh (7th) day after the Effective Date of the Agreement

or

the sixtieth (60th) day after the Bid opening,

whereupon Bid security furnished by such Contractors will be returned. Bid security with Bids which are not competitive will be returned within seven (7) days after the Bid opening.

8. Contract Times.

The number of days within which, or the dates by which, the Work is to be substantially completed and also completed and ready for final payment (the term "Contract Times" is defined in paragraph 1.12 of the General Conditions) are set forth in the Agreement (or incorporated therein by reference to the attached Bid Form).

9. Substitute and "Or-Equal" Items.

The Contract, if awarded, will be on the basis of materials and equipment described in the Drawings or specified in the Specifications. Whenever it is indicated in the Drawings or specified in the specifications that a substitute or "or-equal" item of material or equipment may be furnished or used by Contractor if acceptable to the County, acceptance of the substitution "or equal" to material or equipment, will typically be considered by the County after the contract is awarded. However, any proposed substitution that represents a deviation from the design intent, must be approved prior to submission of the bid responses. A determination as to whether a design deviation or particular item that changes the design intent of the plans or specification is acceptable as a substitute or "equal" will be made by the County and Engineer. Design deviations approved prior to bid submittals will be made known to other

bidders through an addendum. Specific product substitute materials or equipment and requested “or equal” items to be used will be reviewed during the submittal process and follow the procedures outlined in Paragraphs 6.7.1, 6.7.2. and 6.7.3. of the General Conditions.

10. Subcontractors, Suppliers, and Others

10.1 If the Supplementary Conditions require the identity of certain Subcontractors, Suppliers and other persons and organizations (including those who are to furnish the principal items of material and equipment) to be submitted to Owner in advance of a specified date prior to the Effective Date of the Agreement, apparent Successful Contractor, and any other Contractor so requested, shall within 24 hours after Bid opening submit to Owner a list of all such Subcontractors, Suppliers, and other persons and organizations proposed for those portions of the Work for which such identification is required. Such list shall be accompanied by an experience statement with pertinent information regarding similar projects and other evidence of qualification for each such Subcontractor Supplier, person, or organization if requested by Owner. An Owner or Engineer who after due investigation has reasonable objection to any proposed Subcontractor, Supplier, other person, or organization, may before the Notice of Award is given request apparent Successful Contractor to submit an acceptable substitute without an increase in Bid Price.

If apparent Successful Contractor declines to make any such substitution, Owner may award the contract to the next lowest Contractor that proposes to use acceptable Subcontractors, Suppliers, and other persons and organizations. The declining to make requested substitutions will not constitute grounds for sacrificing the Bid security of any Contractor. Any subcontractor, Supplier, other person or organization listed and to whom Owner or Engineer does not make written objection prior to the giving of the Notice of Award will be deemed acceptable to Owner and Engineer subject to revocation of such acceptance after the Effective Date of the Agreement as provided in Paragraph 6.8.2 of the General Conditions.

11. Bid Form.

- 11.1 All blanks on the Bid Form must be completed by printing in ink or by typewriter.
- 11.2 Bids by corporations must be executed in the corporate name by the president or a vice-president (or other corporate officer accompanied by evidence of authority to sign) and the corporate seal must be affixed and attested by the secretary or an assistant secretary. The corporate address and state of incorporation must be shown below the signature.
- 11.3 Bids by partnerships must be executed in the partnership name and signed by a partner, whose title must appear under the signature and the official address of the partnership must be shown below the signature.
- 11.4 All names must be typed or printed in ink below the signature.
- 11.5 The bid shall contain an acknowledgment of receipt of all Addenda (the numbers of which must be filled in on the Bid Form).
- 11.6 The address and telephone number for communications regarding the bid must be shown.

11.7 Evidence of authority to conduct business as an out-of-state corporation in the state where the Work is to be performed shall be provided. State contractor license number, if any, must also be shown.

12. Submission of Bids.

12.1 Contractor shall submit the original plus two (2) copies of their bid to the place indicated in the Advertisement of Notice to Bidder.

12.2 Bids shall be submitted at the time and place indicated in the Advertisement of Notice to Bidder and shall be enclosed in an opaque sealed envelope, marked with the Project title and name and address of Contractor and accompanied by the Bid security and other required documents. If the Bid is sent through the mail or other delivery system the sealed envelope shall be enclosed in a separate envelope with the notation "**BID ENCLOSED – VPS FUEL FARM FALL PROTECTION**" on the face of it.

13. Modification and Withdrawal of Bids.

13.1 Bids may be modified or withdrawn by an appropriate document duly executed (in the manner that a Bid must be executed) and delivered to the place where Bids are submitted at any time prior to the opening of Bids.

13.2 If, within twenty-four hours after Bids are opened, any Contractor files a duly signed, written notice with Owner and promptly thereafter demonstrates to the reasonable satisfaction of Owner that there was a material and substantial mistake in the preparation of its Bid, that Contractor may withdraw its Bid and bid security will be returned. Thereafter, that Contractor will be disqualified from further bids on the Work to be provided under the Project Documents.

14. Opening of Bids.

Bids will be opened and (unless obviously non-responsive) read aloud publicly at the place where Bids are to be submitted. An abstract of the amounts of the base Bids and major alternates (if any) will be made available to Contractors after the opening of Bids.

15. Bids to Remain Subject to Acceptance.

All Bids will remain subject to acceptance for sixty (60) days after the day of the Bid opening, but Owner may, in its sole discretion, release any Bid and return the Bid security prior to that date.

16. Disqualification of Contractors

Any of the following reasons may be considered as sufficient for the disqualification of a contractor and the rejection of his proposal or proposals:

- A. More than one proposal for the same work from an individual, firm or corporation under the same or different name.
- B. Evidence that the contractor has a financial interest in the firm of another contractor for the same work.

- C. Evidence of collusion among contractors. Participants in such conclusion will receive no recognition as contractors for any future work of the County until such participant shall have been reinstated as a qualified contractor.
- D. Uncompleted work that in the judgment of the County might hinder or prevent the prompt completion of additional work if awarded.
- E. Failure to pay or satisfactorily settle all bills due for labor and material on former contracts in force at the time of advertisement for bids.
- F. Default under previous contract.

17. Award of Contract.

- 17.1 Owner reserves the right to reject any or all Bids, including without limitation the rights to reject any or all nonconforming, non-responsive, unbalanced, or conditional Bids and to reject the Bid of any Contractor if Owner believes that it would not be in the best interest of the Project to make an award to that Contractor, whether because the Bid is not responsible or the Contractor is unqualified or of doubtful financial ability or fails to meet any other pertinent standard or criteria established by Owner. Owner also reserves the right to waive all informalities not involving price, time, or changes in the Work. Discrepancies between the multiplication of units of Work and unit prices will be resolved in favor of the unit prices. Discrepancies between the indicated sum of any column of figures and the correct sum thereof will be resolved in favor of the correct sum. Discrepancies between words and figures will be resolved in favor of the words.
- 17.2 Owner may conduct such investigations as Owner deems necessary to assist in the evaluation of any Bid and to establish the responsibility, qualifications, and financial ability of Contractors, proposed Subcontractors, Suppliers, and other persons and organizations to perform and furnish the Work in accordance with the Project Documents to Owner's satisfaction within the prescribed time.
- 17.3 The Owner in its absolute discretion may reject any bid of a Contractor that has failed, in the opinion of the Owner, to complete or perform an Owner-contracted project in a timely fashion, and emphasizes this condition to potential Contractors.
- 17.4 If a contract is to be awarded, it shall be awarded to the responsible and responsive bidder who submits the lowest responsive bid. Owner may request from the proposers additional information to be provided to the County prior to Notice of Award.

18. Pre-Bid Conference.

A **non-mandatory** Pre-Bid Conference will be conducted at the Destin-Fort Walton Beach Airport, Conference Room No. 1, 1701 State Road 85 N., Eglin AFB, Florida 32542, at January 9, 2020 at 11 a.m. (C.S.T.). Engineer, in conjunction with the County's Purchasing Department, will transmit to all plan holders of record such Addenda as Engineer considers necessary in response to written questions received no later than seven (7) days prior to the Bid Opening date. Oral statements may not be relied upon and will not be binding or legally effective.

19. Sales and Use Taxes.

Work under this Bid is subject to the provisions of Chapter 212, Florida Statutes, Tax on state, Use and Other Transactions. Other state, local, or federal taxes may be applicable. The contractor is responsible to remit to the appropriate governmental entity all applicable taxes. Any applicable tax shall be included in the total Bid price by the contractor.

REMAINDER OF PAGE INTENTIONALLY LEFT BLANK

OKALOOSA COUNTY STANDARD CLAUSES

INDEMNIFICATION AND HOLD HARMLESS

CONTRACTOR shall indemnify and hold harmless **COUNTY**, its officers and employees from liabilities, damages, losses, and costs including but not limited to reasonable attorney fees, to the extent caused by the negligence, recklessness, or intentional wrongful conduct of the **CONTRACTOR** and other persons employed or utilized by the **CONTRACTOR** in the performance of this Agreement.

NOTE: For Contractor's convenience, this certification form is enclosed and is made a part of the bid package.

CONFLICT OF INTEREST

The award hereunder is subject to the provisions of Chapter 112, Florida Statutes. All respondents must disclose with the proposal the name of any officer, director, or agent who is also a public officer or an employee of the Okaloosa Board of County Commissioners, or any of its agencies.

Furthermore, all respondents must disclose the name of any County officer or employee who owns, directly or indirectly, an interest of five percent (5%) or more in the firm or any of its branches.

Furthermore, the official, prior to or at the time of submission of the proposal, must file a statement with the Clerk of Circuit Court of Okaloosa County if he is an officer or employee of the County, disclosing his or spouse's or child's interest and the nature of the intended business.

NOTE: For Contractor's convenience, a certification form is enclosed and is made a part of the bid package

IDENTICAL TIE PROPOSALS

In cases of identical procurement responses, the award shall be determined either by lot or on the basis of factors deemed to serve the best interest of the County. In the case of the latter, there must be adequate documentation to support such a decision.

TRENCH SAFETY ACT

Each contractor must submit with his bid an executed sworn certification that he will comply with the Trench Safety Act, Chapter 90-96, Florida Statutes, on trench safety.

NOTE: For Contractor's convenience, a certification form is enclosed and is made a part of the bid package.

PUBLIC ENTITY CRIME INFORMATION

A person or affiliate who has been placed on the convicted vendor list following a conviction for a public entity crime may not submit a bid on a contract to provide any goods or services to a public entity, may not submit a bid on a contract with a public entity for the construction or repair of a public building or public work, may not submit bids on leases of real property to a public entity, may not be awarded or perform work as a contractor, supplier, subcontractor, or consultant under a contract with any public entity, and may not transact business with any public entity in excess of the threshold amount provided in Section 287.107, for CATEGORY TWO for a period of 36 months from the date of being placed on the convicted vendor list.

BONDING REQUIREMENTS

Bid Bond, Payment Bond and Performance Bond, and others as required.

INSURANCE REQUIREMENTS

CONTRACTORS INSURANCE

1. The Contractor shall not commence any work in connection with this Agreement until he has obtained all required insurance and such insurance has been approved by the Okaloosa County Risk Manager or designee.
2. All insurance policies shall be with insurers authorized to do business in the State of Florida.
3. All insurance shall include the interest of all entities named and their respective officials, employees & volunteers of each and all other interests as may be reasonably required by Okaloosa County. The coverage afforded the Additional Insured under this policy shall be primary insurance. If the Additional Insured have other insurance that is applicable to the loss, such other insurance shall be on an excess or contingent basis. The amount of the company's liability under this policy shall not be reduced by the existence of such other insurance.
4. Where applicable, the County shall be shown as an Additional Insured with a Waiver of Subrogation on the Certificate of Insurance.
5. The County shall retain the right to reject all insurance policies that do not meet the requirement of this Agreement. Further, the County reserves the right to change these insurance requirements with 60-day notice to the Contractor.
6. The County reserves the right at any time to require the Contractor to provide copies of any insurance policies to document the insurance coverage specified in this Agreement.
7. The designation of Contractor shall include any associated or subsidiary company which is involved and is a part of the contract and such, if any associated or subsidiary company involved in the project must be named in the Workers' Compensation coverage.

8. Any exclusions or provisions in the insurance maintained by the Contractor that excludes coverage for work contemplated in this agreement shall be deemed unacceptable and shall be considered breach of contract.

WORKERS' COMPENSATION INSURANCE

1. The Contractor shall secure and maintain during the life of this Agreement Workers' Compensation insurance for all of his employees employed for the project or any site connected with the work, including supervision, administration or management, of this project and in case any work is sublet, with the approval of the County, the Contractor shall require the Subcontractor similarly to provide Workers' Compensation insurance for all employees employed at the site of the project, and such evidence of insurance shall be furnished to the County not less than ten (10) days prior to the commencement of any and all sub-contractual Agreements which have been approved by the County.
2. Contractor must be in compliance with all applicable State and Federal workers' compensation laws, including the U.S. Longshore Harbor Workers' Act or Jones Act, if applicable.
3. No class of employee, including the Contractor himself, shall be excluded from the Workers' Compensation insurance coverage. The Workers' Compensation insurance shall also include Employer's Liability coverage.

BUSINESS AUTOMOBILE LIABILITY

Coverage must be afforded for all Owned, Hired, Scheduled, and Non-Owned vehicles for Bodily Injury and Property Damage in an amount not less than \$1,000,000 combined single limit each accident. If the contractor does not own vehicles, the contractor shall maintain coverage for Hired & Non-Owned Auto Liability, which may be satisfied by way of endorsement to the Commercial General Liability policy or separate Business Auto Policy. Contractor must maintain this insurance coverage throughout the life of this Agreement.

COMMERCIAL GENERAL LIABILITY INSURANCE

1. The Contractor shall carry other Commercial General Liability insurance against all other Bodily Injury, Property Damage and Personal and Advertising Injury exposures.
2. All liability insurance (other than Professional Liability) shall be written on an occurrence basis and shall not be written on a claims-made basis. If the insurance is issued with an aggregate limit of liability, the aggregate limit of liability shall apply only to the locations included in this Agreement. If, as the result of any claims or other reasons, the available limits of insurance reduce to less than those stated in the Limits of Liability, the Contractor shall notify the County representative in writing. The Contractor shall purchase additional liability insurance to maintain the requirements established in this Agreement. Umbrella or Excess Liability insurance can be purchased to meet the Limits of Liability specified in this Agreement.
3. Commercial General Liability coverage shall include the following:

- 1.) Premises & Operations Liability
- 2.) Bodily Injury and Property Damage Liability
- 3.) Independent Contractors Liability
- 4.) Contractual Liability
- 5.) Products and Completed Operations Liability

4. Contractor shall agree to keep in continuous force Commercial General Liability coverage for the length of the contract.

LIMITS OF LIABILITY

The insurance required shall be written for not less than the following, or greater if required by law and shall include Employer's liability with limits as prescribed in this contract:

	<u>LIMIT</u>
1. Worker's Compensation	
1.) State	Statutory
2.) Employer's Liability	\$500,000 each accident
2. Business Automobile	\$1M each accident (A combined single limit)
3. Commercial General Liability	\$1M each occurrence for Bodily Injury & Property Damage
	\$1M each occurrence Products and completed operations
4. Personal and Advertising Injury	\$1M each occurrence

NOTICE OF CLAIMS OR LITIGATION

The Contractor agrees to report any incident or claim that results from performance of this Agreement. The County representative shall receive written notice in the form of a detailed written report describing the incident or claim within ten (10) days of the Contractor's knowledge. In the event such incident or claim involves injury and/or property damage to a third party, verbal notification shall be given the same day the Contractor becomes aware of the incident or claim followed by a written detailed report within ten (10) days of verbal notification.

INDEMNIFICATION & HOLD HARMLESS

Contractor shall indemnify and hold harmless the County, its officers and employees from liabilities, damages, losses, and costs including but not limited to reasonable attorney fees, to the extent caused by the negligence, recklessness, or wrongful conduct of the Contractor and other persons employed or utilized by the Contractor in the performance of this contract.

Note: For Contractor's convenience, this certification form is enclosed and is made a part of the bid package.

CERTIFICATE OF INSURANCE

1. Certificates of insurance indicating the job site and evidencing all required coverage must be submitted not less than 10 days prior to the commencement of any of the work. The certificate holder(s) shall be as follows: Okaloosa County, 5479A Old Bethel Road, Crestview, Florida, 32536.
2. The contractor shall provide a Certificate of Insurance to the County with a thirty (30) day notice of cancellation; ten (10 days' notice if cancellation is for nonpayment of premium).
3. In the event that the insurer is unable to accommodate the cancellation notice requirement, it shall be the responsibility of the contractor to provide the proper notice. Such notification shall be in writing by registered mail, return receipt requested, and addressed to the Okaloosa County Purchasing Department at 5479-A Old Bethel Road, Crestview, FL 32536.

GENERAL TERMS

Any type of insurance or increase of limits of liability not described above which, the Respondent required for its own protection or on account of statute shall be its own responsibility and at its own expense.

The carrying of the insurance described shall in no way be interpreted as relieving the Respondent of any responsibility under this contract.

Should the Respondent engage a subcontractor or sub-subcontractor, the same conditions will apply under this Agreement to each subcontractor and sub-subcontractor.

The Respondent hereby waives all rights of subrogation against Okaloosa County and its consultants and other indemnities of the Respondent under all the foregoing policies of insurance.

UMBRELLA INSURANCE

The Respondent shall have the right to meet the liability insurance requirements with the purchase of an umbrella insurance policy. In all instances, the combination of primary and umbrella liability coverage must equal or exceed the minimum liability insurance limits stated in this Agreement.

DELIVERY OF BIDS

Bid Opening shall be public, on the date and time specified on the NOTICE TO CONTRACTORS. It is the contractor's responsibility to assure that his bid is delivered at the proper time and place. Offers by telegram, facsimile, or telephone are NOT acceptable. NOTE: Crestview, Florida is "not a next-day-guaranteed delivery location" by delivery services.

Liquidated Damages:

- a. In case of failure on the part of the Contractor to complete the work within the time(s) specified in the contract, or within such additional time(s) as may be granted by Okaloosa County, the County will suffer damage, the amount of which is difficult, if not impossible, to ascertain. Therefore, the Contractor shall pay to the County, as liquidated damages, the amount established in the schedule below for each calendar day of delay that actual completion extends beyond the time limit specified until such reasonable time as may be required for final completion of the work. In no way shall costs for liquidated damages be construed as penalty on the contractor.

Daily Charge

<u>Original Contract Amount</u>	<u>Per Calendar Day</u>
\$50,000 and under	\$ 311
Over \$50,000 but less than \$250,000	972
\$250,000 but less than \$500,000	1584
\$500,000 but less than \$2,500,000	1924
\$2,500,000 but less than \$5,000,000	2694
\$5,000,000 but less than \$10,000,000	3902
\$10,000,000 but less than \$15,000,000	6102
\$15,000,000 but less than \$20,000,000	7022
\$20,000,000 and over	7022 plus 0.2% for any amount over \$20 million

- b. **Determination of Number of Days of Default:** For all contracts, regardless of whether the contract time is stipulated in calendar days or working days, the default days shall be counted in calendar days.
- c. **Conditions under which Liquidated Damages are Imposed:** Should the Contractor or, in case of his default, the Surety, fail to complete the work within the time stipulated in the contract, or within such extra time as may have been granted by the County, the Contractor or, in case of his default, the Surety, shall pay to the County, not as a penalty, but as liquidated damages, the amount as provided above.
- d. **Right of Collection:** The County shall have the right to apply as payment on such liquidated damages any money which is due to the Contractor by the County.
- e. **Permitting Contractor to Finish Work:** Permitting the Contractor to continue and to finish the work, or any part of it, after the expiration of the contract time allowed, including extensions of time granted to the Contractor, shall in no way act as a waiver on the part of the County the liquidated damages due under the contract.
- f. **Completion of Work by County:** In case of default of the contract and the completion of the work by the County, the Contractor and his Surety shall be liable for the liquidated damages under the contract, but no liquidated damages shall be chargeable for any delay in the final completion of the work by the County due to any unreasonable action or delay on the part of the County.

BID DOCUMENTS



BID DOCUMENTS
VPS FUEL FARM FALL PROTECTION

BID FORM

PROJECT IDENTIFICATION:

VPS FUEL FARM FALL PROTECTION

THIS BID IS SUBMITTED TO:

OKALOOSA COUNTY PURCHASING DEPARTMENT

1. The undersigned Contractor proposes and agrees, if this Bid is accepted, to enter into an agreement with Owner in the form included in these documents to perform and furnish all Work as specified or indicated in these documents for the Bid Price and within the Bid Times indicated in this Bid and in accordance with the other terms and conditions of these documents.
2. Contractor accepts all of the terms and conditions of the Advertisement or Invitation to Bid and Instructions to Contractors, including without limitation those dealing with the disposition of Bid security. This Bid will remain subject to acceptance for sixty (60) days after the day of Bid opening. Contractor will sign and deliver the required number of counterparts of the Agreement with the Bonds and other documents required by the Project Requirements within fifteen (15) days after the date of Owner's Notice of Award.
3. In submitting this Bid, Contractor represents as more fully set forth in the Agreement, that:
 - (a) Contractor has examined and carefully studied the Project Documents and the following Addenda receipt of all which is hereby acknowledged: (List Addenda by Addendum Number and Date)

Addendum No. _____ Date _____

Addendum No. _____ Date _____

Addendum No. _____ Date _____

Addendum No. _____ Date _____

- (b) Contractor has visited the site and become familiar with and is satisfied as to the general, local, and site conditions that may affect cost, progress, performance, and furnishing of the Work.
- (c) Contractor is familiar with and is satisfied as to all federal, state, and local Laws and Regulations that may affect cost, progress, performance, and furnishing of the Work.
- (d) Contractor has carefully studied all reports of explorations and tests of subsurface conditions at or contiguous to the site and all drawings of physical conditions in or relating to existing surface or subsurface structures at or contiguous to the site (except underground facilities) which have been identified in the Supplementary Conditions as provided in paragraph 4.2.1 of the General Conditions. Contractor accepts the determination set forth in Article 4 of the Supplementary Conditions of the extent of the "technical data" contained in such reports and drawings upon

which Contractor is entitled to rely as provided in paragraph 4.2 of the General Conditions. Contractor acknowledges that such reports and drawings are not Contract Documents and may not be complete for Contractor's purposes. Contractor acknowledges that Owner and Engineer do not assume responsibility for the accuracy or completeness of information and data shown or indicated in the Project Documents with respect to underground facilities at or contiguous to the site. Contractor has obtained and carefully studied (or assumes responsibility for having done so) all such additional or supplementary examinations, investigations, explorations, tests, studies, and data concerning conditions (surface, subsurface, and underground facilities) at or contiguous to the site or otherwise which may affect cost progress, performance or furnishing of the Work or which relate to any aspect of the means, methods, techniques, sequences, and procedures of construction to be employed by Contractor and safety precautions and programs incident thereto. Contractor does not consider that any additional examinations, investigations, explorations, tests, studies or data are necessary for the determination of this Bid for performance and furnishing of the Work in accordance with the times, price, and other terms and conditions of these Documents.

- (e) Contractor is aware of the general nature of Work to be performed by Owner and others at the site that relates to Work for which this Bid is submitted as indicated in these documents.
 - (f) Contractor has correlated the information known to Contractor, information and observation obtained from visits to the site, reports and drawings identified in these documents and all additional examinations, investigations, explorations, tests, studies, and data with these documents.
 - (g) Contractor has given Engineer written notice of all conflicts, errors, ambiguities or discrepancies that Contractor has discovered in these documents and the written resolution thereof by Engineer is acceptable to Contractor, and these documents are generally sufficient to indicate and convey understanding of all terms and conditions for performing and furnishing the Work for which this Bid is submitted.
 - (h) This Bid is genuine and not made in the interest of or on behalf of any undisclosed person, firm, or corporation and is not submitted in conformity with any agreement or rules of any group, association, organization, or corporation; Contractor has not directly or indirectly induced or solicited any other Contractor to submit a false or sham Bid; Contractor has not solicited or induced any person, firm or corporation to refrain from Project; and Contractor has not sought by collusion to obtain for itself any advantage over any other Contractor or over Owner.
4. Contractor will complete the Work in accordance with these documents for the price found in the Bid Schedule:

Unit Prices have been computed in accordance with paragraph 11.9.2 of the General Conditions.

Contractor acknowledges that quantities are not guaranteed and final payment will be based on actual quantities determined as provided in these documents.

5. Contractor agrees that Work will be substantially complete 120 calendar days after the date when the Contract Time commences to run as provided in paragraph 2.3 of the General Conditions, and

will be completed and ready for final payment in accordance with paragraph 14.13 of the general conditions within 140 calendar days after the date when the Contract Time commences to run.

6. Contractor accepts the provisions of the Agreement as to liquidated damages in the event of failure to achieve substantial complete of the Work within the Substantial Completion time and achieve final completion of the work within the Final Completion time as specified in the Agreement.
7. The following documents are attached to and made a condition of this Bid:
 - a) Bid Security as required by the Instructions to Contractors in the form of a certified or bank check made payable to The Board of County Commissioners of Okaloosa County or a Bid Bond on form attached, issued by a surety meeting the requirements of Paragraph 5.1 of the General Conditions. (ITC-1 to ITC-8)
 - b) Bid Schedule (BS-1)
 - c) Bid Affidavit (BA-1)
 - d) Bid Bond (BB-1 to BB-2)
 - e) Required Contractor's Qualification Statement with supporting data. (CQQ-1 to CQQ-3)
 - f) Form of Noncollusion Affidavit (NCA-1)
 - g) Certification of Non-Segregated Facilities (NSF-1)
 - h) Public Entity Crimes (SSPEC-1 to SSPEC-3)
 - i) Certificate as to Corporate Principal (CCP-1)
 - j) Certified Copy of Resolution of Board of Directors (RBD-1)
 - k) Conflict of Interest Disclosure Form (OC-1)
 - l) Drug-Free Workplace Certification (OC-2)
 - m) Certification of Contractor Regarding Trench Safety (OC-3)
 - n) Indemnification and Hold Harmless (OC-4)
 - o) Insurance Compliance (OC-5)
 - p) Affidavit – Worker's Compensation (OC-6)
 - q) Recycled Content Form (OC-7)
 - r) Disadvantaged Business Enterprise Program (OC-8 to OC-11)
 - s) DBE Certificate of Compliance Form (OC-12)

- t) A tabulation of Performance of Work by Subcontractors that Contractor prepares to use. (PWSC-1)
- u) E-Verify Compliance Certification (EVCC-1)
- v) Cone of Silence (CS-1)
- w) Buy American Certificate (BAC-1)
- x) Lobbying – 31 USC 1352 (LF-1)
- y) Equal Employment Opportunity Report Statement (EEO-1)

8. Communications concerning this Bid shall be addressed to the address of Contractor indicated below.

9. Terms used in this Bid which are defined in the General Conditions or Instructions to Contractors will have the meanings indicated in the General Conditions or Instructions.

10. Contractor acknowledges that the Basis of Award shall be the Total Bid Amount, price and other factors considered. The bid bond amount shall be in the amount of the Total Bid Amount.

SUBMITTED on _____, 20__

State Contractor License No. _____

If Contractor is:

An Individual

By _____ (SEAL)

(Individual's Name)

doing business as _____

Business address: _____

Phone No.: _____

A Partnership

By _____ (SEAL)

(Firm Name)

(General Partner)

Business address: _____

Phone No.: _____

A Corporation

By _____ (SEAL)

(Corporation Name)

(State of Incorporation)

By _____ (SEAL)

(Name of person authorized to sign)

(Title)

(Corporate Seal)

Attest _____

(Secretary)

Business address: _____

Phone No.: _____

Date of Incorporation is _____

A Joint Venture

By _____ (SEAL)

(Name)

(Address)

By _____ (SEAL)

(Name)

(Address)

Phone Number and Address for receipt of official communications

(Each joint venturer must sign. The manner of signing for each individual, partnership and corporation that is a party to the joint venture should be in the manner indicated above).

BID SCHEDULE

BIDDER: _____ **DATE:** _____

PROJECT DESCRIPTION: VPS FUEL FARM FALL PROTECTION

BID SCHEDULE

BASE BID

For all work required to furnish and install the catwalks for Fuel Tanks 1 through 6 in accordance with the construction drawings, specifications, and other contract documents, including all costs related to the work, and any required permits, taxes, bonds and insurance, the undersigned submits a total lump sum Base Bid amount of:

TOTAL LUMP SUM BASE BID AMOUNT (in words): _____

_____ Dollars and _____ cents

(\$ _____)

(amount in numbers)

ADDITIVE ALTERNATE NO. 1

For all work required to furnish and install the catwalks for Fuel Tanks 7 and 8 in accordance with construction drawings, specifications, and other contract documents, including all costs related to the work, and any required permits, taxes, bonds and insurance, the undersigned submits a total lump sum Additive Alternate No. 1 amount of:

TOTAL LUMP SUM ADDITIVE ALTERNATE NO. 1 BID AMOUNT (in words): _____

_____ Dollars and _____ cents

(\$ _____)

(amount in numbers)

ADDITIVE ALTERNATE NO. 2

For all work required to furnish and install four (4) pad-eyes and two (2) cables (on both Tanks 7 and 8) for installation of horizontal lifeline systems in accordance with construction drawings, specifications, and other contract documents, including all costs related to the work, and any required permits, taxes, bonds and insurance, the undersigned submits a total lump sum Additive Alternate No. 2 amount of:

TOTAL LUMP SUM ADDITIVE ALTERNATE NO. 2 BID AMOUNT (in words): _____

_____ Dollars and _____ cents

(\$ _____)

(amount in numbers)

BID SUMMARY (amount in numbers)

- (A) TOTAL BASE BID AMOUNT: \$ _____
- (B) TOTAL ADDITIVE ALTERNATE NO. 1 AMOUNT: \$ _____
- (C) TOTAL ADDITIVE ALTERNATE NO. 2 AMOUNT: \$ _____

Contractor acknowledges that the Basis of Award shall be the Base Bid, or any combination of the Base Bid and Additive Alternates ultimately awarded by the County, price and other factors considered. The bid bond amount shall be in the amount of the Base Bid and Additive Alternate No. 1.

Note: The successful bidder shall provide a detailed schedule of values to be used to evaluate percentage of completion during each pay application.

The Bidder represents that it has examined the site of the Work and informed itself fully in regard to all conditions pertaining to the place where the work is to be done; that it has examined the plans and specifications for the work and other Contract Documents relative thereto and has read all of the Addenda furnished prior to the opening of the Bids, as acknowledged below; and that it has otherwise fully informed itself regarding the nature, extent, scope and details of the Work to be performed.

If provided with a Notice of Intent to Award the Contract by the Owner, the Bidder shall execute and deliver to the Owner all of the documents required by the Contract Documents, including but not limited to, the Addendum to the Agreement and the Performance and Payment Bonds in the form contained in the Contract Documents, furnish the required evidence of the specified insurance coverages, furnish all necessary permits, license, materials, equipment, machinery, maintenance, tools, apparatus, means of transportation and labor necessary to complete the Work.

Dated and signed at _____, _____, this _____ day of _____, 2020.

(Name of Bidder)

(Authorized Signature)

(Title)

(Mailing Address)

(City, State, Zip)

(Federal ID No. or SS No.)

BID AFFIDAVIT

The following affidavit must be executed in order that your quotation may be considered.

STATE OF _____

COUNTY OF _____

_____ of lawful age, being first duly sworn, upon his oath deposes and says: That he executed the accompanying Quotation of behalf of the Contractor therein named, and that he had lawful authority so to do, and said Contractor has not directly or indirectly, entered into any agreement, expressed or implied, with any Contractor or Contractors, having to its object the controlling of the price or amount of such quotation or any quotations, the limiting of the Quotation or Contractors, the parceling or farming out to any Contractor or Contractors, to other persons of any part of the contract or any of the subject matter or the Quotations, or of the profits thereof, and that he has not and will not divulge the sealed Quotation to any person whomsoever, except those having a partnership or other financial interest with him in said Quotation or Quotations, until after the sealed Quotation or Quotations are opened.

[signature]

[date]

STATE OF _____ COUNTY OF _____

PERSONALLY APPEARED BEFORE ME, the undersigned authority,

[name of individual signing]

who, after first being sworn by me, affixed his/her signature in the space provided above on this day of _____, 20__.

Subscribed and sworn to before me this _____ day of _____, 20__.

My Commission Expires:

Notary Public

BID BOND

CONTRACTOR (Name and Address):

SURETY (Name and Address of Principal Place of Business):

OWNER (Name and Address):

Okaloosa County
5479A Old Bethel Road
Crestview, FL 32536

BID:

BID DUE DATE: _____
PROJECT (Brief Description Including Location): _____
VPS FUEL FARM FALL PROTECTION
Okaloosa County, Florida

BOND:

BOND NUMBER: _____
DATE: (Not later than Bid Due Date): _____
PENAL SUM: _____

IN WITNESS WHEREOF, Surety and Contractor, intending to be legally bound hereby, subject to the terms printed on the reverse side hereof, do each cause this Bid bond to be duly executed on its behalf by its authorized officer, agent, or representative.

CONTRACTOR

SURETY

(Seal)

(Seal)

Contractor's Name and Corporate Seal

Surety's Name and Corporate Seal

By: _____

By: _____

Signature and Title

Signature and Title
(Attach Power of Attorney)

Attest: _____

Attest: _____

Signature and Title

Signature and Title

Note: (1) Above addresses are to be used for giving required notice.

- (2) Any singular reference to Contractor, Surety, Owner or other party shall be considered plural where applicable.

EJCDC NO. 1910-28-C (1990 Edition)

1. Contractor and Surety, jointly and severally, bind themselves, their heirs, executors, administrators, successors and assigns to pay to OWNER upon default of Contractor the penal sum set forth on the face of this Bond.
2. Default of Contractor shall occur upon the failure of Contractor to deliver within the time required by the Project Documents the executed Agreement required by the Project Documents and any performance and payment bonds required by the Project Documents and Contract Documents.
3. This obligation shall be null and void if:
 - 3.1. OWNER accepts Contractor's Bid and Contractor delivers within the time required by the Project Documents (or any extension thereof agreed to in writing by OWNER) the executed Agreement required by the Project Documents and any performance and payment bonds required by the Project Documents and Contract Documents, or
 - 3.2 All Bids are rejected by OWNER, or
 - 3.3 OWNER fails to issue a notice of award to Contractor within the time specified in the Project Documents (or any extension thereof agreed to in writing by Contractor and, if applicable, consented to by Surety when required by paragraph 5 hereof).
4. Payment under this Bond will be due and payable upon default of Contractor and within 30 calendar days after receipt by Contractor and Surety of written notice of default from OWNER, which notice will be given with reasonable promptness, identifying this Bond and the Project and including a statement of the amount due.
5. Surety waives notice of and any and all defenses based on or arising out of any time extension to issue notice of award agreed to in writing by OWNER and Contractor, provided that the time for issuing notice of award including extensions shall not in the aggregate exceed 120 days from Bid Due Date without Surety's written consent.
6. No suit or action shall commence under this Bond prior to 30 calendar days after the notice of default required in paragraph 4 above is received by Contractor and Surety, and in no case later than one year after Bid Due Date.
7. Any suit or action under this Bond shall be commenced only in a court of competent jurisdiction located in the state in which the Project is located.
8. Notice required hereunder shall be in writing and sent to Contractor and Surety at their respective addresses shown on the face of this Bond. such notices may be sent by personal deliver, commercial courier or by United States Registered or Certified Mail, return receipt requested, postage pre-paid, and shall be deemed to be effective upon receipt by the party concerned.

9. Surety shall cause to be attached to this Bond a current and effective Power of Attorney evidencing the authority of the officer, agent or representative who executed this Bond on behalf of Surety to execute, seal and deliver such Bond and bind the Surety thereby.

10. This Bond is intended to conform to all applicable statutory requirements. Any applicable requirement of any applicable statute that has been omitted from this Bond shall be deemed to be included herein as if set forth at length. If any provision of any Bond conflicts with any applicable provision of any applicable statute, then the provision of said statute shall govern and the remainder of this Bond that is not in conflict therewith shall continue in full force and effect.

11. The term "Bid" as used herein includes a Bid, offer, or proposal as applicable.

10. Provide a financial statement for your company. This should include a balance and income statement for your most recent fiscal year. A certified audit is preferred but not required. Use an insert sheet, if needed. Only three (3) lowest bidders shall submit this information (if requested by Owner) to the Owner within two (2) business days of the opening of the Bids.

11. State the true, exact, correct and complete name of the partnership, corporation or trade name under which you do business, and the address of the place of business. (If a corporation, state the name of all partners. If a trade name, state the names of the individuals who do business under the trade name.) It is absolutely necessary that information be furnished.

Correct Name of Contractor _____

(a) The business is a _____

(b) The address of principal place of business is:

(c) The names of the corporate officers, or partners, or individuals doing business under a trade name, are as follows:

FORM OF NONCOLLUSION AFFIDAVIT

(This Affidavit is Part of Bid)

STATE OF _____

COUNTY OF _____

_____ Being

first duly sworn, deposes and says that he is

_____ (Sole owner, a partner, president, secretary, etc.) of

_____ the party making the foregoing Proposal or BID that such BID is genuine and not collusive or sham; that said CONTRACTOR has not colluded, conspired, connived, or agreed, directly or indirectly, with any CONTRACTOR or person, to put in a sham BID, or that such other person shall refrain from the project, and has not in any manner, directly or indirectly sought by agreement or collusion, or communication or conference, with any person, to fix the Bid Price of affiant or any other CONTRACTOR, or to fix any overhead, profit or cost element of said Bid Price, or of that of any other CONTRACTOR, or to secure any advantage against OWNER any person interested in the proposed Contract; and that all statements in said Proposal or Bid are true; and further, that such CONTRACTOR has not, directly or indirectly submitted this BID, or the contents thereof, or divulged information or date relative thereto to any association or to any member or agent thereof.

_____ (Contractor)

Sworn to and subscribed before me this ____ day of

_____, 20__.

Notary Public in and for

_____ County,

_____.

My Commission Expires:

_____, 20__.

CERTIFICATION OF NON-SEGREGATED FACILITIES

(Must be completed and submitted with the Bid)

The Contractor certifies that it does not maintain or provide for its employee any segregated facilities at any segregated facilities at any of its establishments, and that it does not permit its employees to perform their services at any location under its control where segregated facilities are maintained. The Contractor certifies further that it will not maintain or provide for its employees segregated facilities at any of its establishments, and that it will not permit its employees to perform their services at any location under its control where segregated facilities are maintained. The Contractor agrees that a breach of this certification is a violation of the equal opportunity clause in this contract. As used in this certification, the term "segregated facilities" means any waiting room, work areas, restrooms and washrooms, restaurants and other eating areas, parking lots, drinking fountains, recreation or entertainment areas, transportation and housing facilities provided for employees which are segregated by explicit directive or are in fact segregated on basis of race, color, religion, or national origin, because of habit, local custom, or any other reason. The Contractor agrees that (except where it has obtained identical certification from proposed subcontractors for the specific time period) it will obtain identical certifications from proposed subcontractors prior to the award of subcontracts exceeding \$10,000 which are not exempt from the provisions of the equal opportunity clause, and that it will retain such certification in its files.

(Name of Contractor)

By: _____

Title: _____

Dated: _____

**SWORN STATEMENT UNDER SECTION 287.133 (3) (a),
FLORIDA STATUTES, ON PUBLIC ENTITY CRIMES**

THIS FORM MUST BE SIGNED AND SWORN IN THE PRESENCE OF A NOTARY PUBLIC OR OTHER OFFICIAL AUTHORIZED TO ADMINISTER OATHS.

1. This sworn statement is submitted to _____
[print name of public entity]

by _____
[print individuals name and title]

for _____
[print name of entity submitting sworn statement]

whose business is _____ and (if applicable) its
Federal Employer Identification Number (FEIN) is _____ (If the entity has no FEIN,
include the Social Security Number of the individual signing this sworn statement: _____.)

2. I understand that a "public entity crime" as defined in Section 287.133 (1) (g), Florida Statutes, means a violation of any state or federal law by a person with respect to and directly related to the transaction of business with any public entity or with an agency or political subdivision of any other state or of the United States, including, but not limited to, any bid or contract for goods or services to be provided to any public entity or an agency or political subdivision of any other state or of the United States and involving antitrust, fraud, theft, bribery, collusion, racketeering, conspiracy, or material misrepresentation.

3. I understand that "convicted" or "conviction" as defined in Section 287.133 (1) (b), Florida Statutes, means a finding of guilt or a conviction of a public entity crime, with or without an adjudication of guilt, in any federal or state trial court of record relating to charges brought by indictment or information after July 1, 1989, as a result of a jury verdict, non-jury trial, or entry of a plea of guilty or nolo contendere.

4. I understand that an "affiliate" as defined in Section 287.133 (1) (a), Florida Statutes, means:

A. A predecessor or successor of a person convicted of a public entity crime; or

B. An entity under the control of any natural person who is active in the management of the entity and who has been convicted of a public entity crime. The term "affiliate" includes those officers, directors, executives, partners, shareholders, employees, members and agents who are active in the management of an affiliate. The ownership by one person of shares constituting a controlling interest in another person, or a pooling of equipment or income among persons when not for fair market value under an arm's length agreement, shall be a prima facie case that one person controls another person. A person who knowingly enters into a joint venture with a person who has been convicted of a public entity crime in Florida during the preceding 36 months shall be considered an affiliate.

5. I understand that a "person" as defined in Section 287.133 (1) (e) Florida Statutes, means any natural person or entity organized under the laws of any state or of the United States with the legal power to enter into a binding contract and which bids or applies to bid on contracts for the provision of goods or services let by a public entity, or which otherwise transacts or applies to transact business with a public entity. The term "person" includes those officers, directors, executives, partners, shareholders, and employees, members, and agents who are active in management of an entity.

6. Based on information and belief, the statement which I have marked below is true and in relation to the entity submitting this sworn statement. **[Indicate which statement applies.]**

Neither the entity submitting this sworn statement, nor any of its officers, directors, executives, partners, shareholders, employees, members, or agents who are active in the management of the entity, nor any affiliate of the entity has been charged with and convicted of a public entity crime subsequent to July 1, 1989.

The entity submitting this sworn statement, or one or more of its officers, directors, executives, partners, shareholders, employees, members, or agents who are active in the management of the entity, or an affiliate of the entity has been charged with and convicted of a public entity crime subsequent to July 1, 1989.

The entity submitting this sworn statement, or one or more of its officers, directors, executives, partners, shareholders, employees, members, or agents who are active in the management of the entity, or an affiliate of the entity has been charged with and convicted of a public entity crime subsequent to July 1, 1989. However, there has been a subsequent proceeding before a Hearing Officer of the State of Florida, Division of Administrative Hearings and the Final Order entered by the Hearing Officer determined that it was not in the public interest to place the submitting this sworn statement on the convicted vendor list. **[attach a copy of the final order]**

I UNDERSTAND THAT THE SUBMISSION OF THIS FORM TO THE CONTRACTING OFFICER FOR THE PUBLIC ENTITY IDENTIFIED IN PARAGRAPH 1 (ONE) ABOVE IS FOR THAT PUBLIC ENTITY ONLY AND, THAT THIS FORM IS VALID THOROUGH DECEMBER 31 OF THE CALENDAR YEAR IN WHICH IT IS FILED. I ALSO UNDERSTAND THAT I AM REQUIRED TO INFORM THE PUBLIC ENTITY PRIOR TO ENTERING INTO A CONTRACT IN EXCESS OF THE THRESHOLD AMOUNT PROVIDED IN SECTION 287.107, FLORIDA STATUTES FOR CATEGORY TWO ON ANY CHANGE IN THE INFORMATION CONTAINED IN THIS FORM.

[signature]

[date]

STATE OF _____ COUNTY OF _____

PERSONALLY APPEARED BEFORE ME, the undersigned authority,

[name of individual signing]

who, after first being sworn by me, affixed his/her signature in the space provided above on this day of _____, 20__.

Subscribed and sworn to before me this _____ day of _____, 20__.

My Commission Expires:

Notary Public

CERTIFICATE AS TO CORPORATE PRINCIPAL

I, _____, certify that I am the Secretary of the Corporation named as Principal in the within bond; that _____ who signed the bond on behalf of the Principal, was then _____ of said Corporation; that I know his/her signature, and his/her signature hereto is genuine; and that said bond was duly signed, sealed, and attested for and in behalf of said Corporation by authority of its governing body.

Secretary (Corporate Seal)

**STATE OF FLORIDA
COUNTY OF**

Before me, a Notary Public, duly commissioned, qualified and acting, personally appeared _____ to me well known, who being my first duly sworn upon oath, says that he/she is the Attorney-in-Fact, for the _____ and that he has been authorized by _____ to execute the foregoing bond on behalf of the Contractor named therein in favor of Okaloosa County.

Subscribed and sworn to before me this ____ day of _____, 20__, A.D.

[Attach Power of Attorney to Original Bid Bond and Financial Statement from Surety Company]

Notary Public
State of Florida-at-Large

My commission Expires:

**CERTIFIED COPY OF RESOLUTION OF
BOARD OF DIRECTORS OF**

(NAME OF CORPORATION)

"RESOLVED that, _____
(Person Authorized to Sign) (Title)

of _____
(Name of Corporation)

is authorized to sign and submit the Bid of this corporation for the following Project:

VPS FUEL FARM FALL PROTECTION

and to include in such bid the certificate as to non-collusion, and for any inaccuracies or misstatements in such certificate this corporate Contractor shall be liable under the penalties of perjury.

The foregoing is a true and correct copy of the resolution adopted by

(NAME OF CORPORATION)

at a meeting of its Board of Directors held on the _____ day of _____, 20__.

By _____

Title _____

(SEAL)

The above form must be completed if the Contractor is a Corporation.

CONFLICT OF INTEREST DISCLOSURE FORM

For purposes of determining any possible conflict of interest, all contractors/proposers, must disclose if any Okaloosa Board of County Commissioner, employee(s), elected officials(s), or if any of its agencies is also an owner, corporate officer, agency, employee, etc., of their business.

Indicate either "yes" (a county employee, elected official, or agency is also associated with your business), or "no." If yes, give person(s) name(s) and position(s) with your business.

YES _____ NO _____

NAME(S)	POSITION(S)
_____	_____
_____	_____
_____	_____
_____	_____

FIRM NAME: _____

BY (PRINTED): _____

BY (SIGNATURE): _____

TITLE: _____

ADDRESS: _____

PHONE NO.: _____

DRUG-FREE WORKPLACE CERTIFICATION

THE BELOW SIGNED CONTRACTOR CERTIFIES that it has implemented a drug-free workplace program. In order to have a drug-free workplace program, a business shall:

1. Publish a statement notifying employees that the unlawful manufacture, distribution, dispensing, possession, or use of a controlled substance is prohibited in the workplace and specifying the actions that will be taken against employees for violations of such prohibition.
2. Inform employees about the dangers of drug abuse in the workplace, the business's policy of maintaining a drug-free workplace, any available drug counseling, rehabilitation and employee assistance programs, and the penalties that may be imposed upon employees for drug abuse violations.
3. Give each employee engaged in providing the commodities or contractual services that are under bid a copy of the statement specified in subsection 1.
4. In the statement specified in subsection 1, notify the employees that, as a condition of working on the commodities or contractual services that are under bid, the employee will abide by the terms of the statement and will notify the employer of any conviction of, or plea of guilty or nolo contendere to, to any violation of Chapter 893 or of any controlled substance law of the United States or any state, for a violation occurring in the workplace no later than five (5) days after such conviction.
5. Impose a sanction on, or require the satisfactory participation in drug abuse assistance or rehabilitation program if such is available in the employee's community, by any employee who is convicted.
6. Make a good faith effort to continue to maintain a drug-free workplace through implementation of this section.

As the person authorized to sign this statement, I certify that this firm complies fully with the above requirements.

DATE: _____

COMPANY: _____

SIGNATURE: _____

ADDRESS: _____

NAME: _____
(Typed or Printed)

TITLE: _____

PHONE #: _____

CERTIFICATION OF CONTRACTOR REGARDING TRENCH SAFETY

This certification is required pursuant to the Trench Safety Act, Chapter 90-98, Florida Statutes regarding Trench Safety. The Act specifically incorporates the Occupational Safety and Health Administration's excavation safety standards, 29 CFR S. 1928.650 Subpart P as the state standard. Any revision to OSHA's safety standards that are consistent with the Florida Statutes shall also be complied with upon its effective date. The act requires that any bidder or prospective contractor, or any of their proposed subcontractors, shall provide written assurance that the contractor will comply with the applicable trench safety standards

NAME AND ADDRESS OF CONTRACTOR (Include Zip Code)

1. Contractor agrees that he is aware of the Trench Safety Act and the requirements of the Act.

Yes _____ No _____

2. Contractors agrees to comply with all applicable trench safety standards as set forth in the Act and as referenced in the Act.

Yes _____ No _____

NAME AND TITLE OF SIGNER (Please Print or Type)

SIGNATURE _____

DATE _____

INDEMNIFICATION AND HOLD HARMLESS

CONTRACTOR shall indemnify and hold harmless COUNTY, its officers and employees from liabilities, damages, losses, and costs including but not limited to reasonable attorney fees, to the extent caused by the negligence, recklessness, or intentional wrongful conduct of the CONTRACTOR and other persons employed or utilized by the CONTRACTOR in the performance of this Agreement.

Contractor's Company Name

Authorized Signature - Manual

Physical Address

Authorized Signature - Typed

Mailing Address

Title

Phone Number

FAX Number

Cellular Number

After-Hours Number(s)

Date

INSURANCE COMPLIANCE

This form is to be completed and signed the Contractor and by your insurance agent/carrier certifying that your policy either meets the insurance requirements (as specified in page BOC-2 to BOC-6) or that the insurance company has reviewed the bid requirements and certifies that you were bidd any price increase due to required coverage.

CONTRACTOR

I certify that the insurance requirements have been reviewed.

Company Name _____

Address _____

Representative

Name _____

Title _____

Phone Number _____

INSURANCE COMPANY

I certify that the insurance requirements have been reviewed with the above contractor.

Company Name _____

Address _____

Representative

Name _____

Title _____

Phone Number _____

AFFIDAVIT - WORKER'S COMPENSATION

State of _____

County of _____

SS: _____

of _____

being duly sworn, deposes and says that he now carries or that he has applied for a Worker's Compensation Policy to cover the operations, as set forth in the preceding contract, and to comply with the provisions thereof.

Signed: _____

Subscribed and sworn to before me this _____ day of _____, 20 ____

Notary Public

RECYCLED CONTENT FORM

RECYCLED CONTENT INFORMATION:

1. Is the material in the above: VIRGIN _____ or RECYCLED _____
(Check the applicable blank)
If RECYCLED, what percentage _____%.

Product Description: _____

2. Is your product packaged and/or shipped in material containing recycled content?
Yes _____ No _____

Specify: _____

3. Is your product recyclable after it has reached its intended end use?
Yes _____ No _____

Specify: _____

The above is not applicable if there is only a personal service involved with no product involvement.

Name of Contractor:

DISADVANTAGED BUSINESS ENTERPRISE PROGRAM

The following bid condition applies to this Department of Transportation (DOT) assisted contract. Submission of a bid/proposal by a prospective contractor shall constitute full acceptance of these bid conditions.

1. **DEFINITION** - Disadvantaged Business Enterprise (DBE) as used in this contract shall have the same meaning as defined in 49 CFR Part 26.
2. **POLICY** - It is the policy of DOT that DBE's as defined in 49 CFR Part 26 shall have the maximum opportunity to participate in the performance of contracts and subcontracts financed in whole or in part with Federal funds. Consequently, the DBE requirements of 49 CFR Part 26 apply to this contract.
3. **OBLIGATION** - The contractor agrees to ensure that DBE's as defined in 49 CFR Part 26 have the maximum opportunity to participate in the performance of contracts and subcontracts financed in whole or in part with Federal funds. In this regard, all contractors shall take all necessary and reasonable steps in accordance with 49 CFR Part 26 to ensure that DBE's have the maximum opportunity to compete for and perform contracts. Contractors shall not discriminate on the basis of race, color, national origin, or sex in the award and performance of DOT assisted contracts.
4. **COMPLIANCE** - All bidders, potential contractors, or subcontractors for this DOT assisted contract are hereby notified that failure to carry out the DOT policy and the DBE obligation, as set forth above, shall constitute a breach of contract which may result in termination of the contract or such other remedy as deemed appropriate by the owner.
5. **CONTRACT CLAUSE** - All bidders and potential contractors hereby assure that they will include the above clauses in all subcontracts, which offer further subcontracting opportunities.
6. **CONTRACT AWARD** - Bidders are hereby advised that meeting the DBE subcontract goal or making an acceptable good faith effort to meet said goal are conditions of being awarded this DOT assigned contract.

The owner proposes to award the contract to the lowest responsive and responsible bidder submitting a reasonable bid provided he has met the goal for DBE participation or, if failing to meet the goal, he has made an acceptable good faith effort to meet the established goal for DBE participation. Bidder is advised that the owner reserves the right to reject any or all bids submitted.

7. **DBE PARTICIPATION GOAL** –No specific DBE goal has been established for this project; however, the contractor must make a good faith effort to include as much DBE participation as possible and must document the anticipated DBE participation on the next page.
8. **AVAILABLE DBE'S** – The FDOT maintains an online searchable database of DBE firms at <https://www3.dot.state.fl.us/equalopportunityoffice/biznet>. This program contains listing of DBE's (certified and noncertified). Bidders are encouraged to inspect this list to assist in locating DBEs for the work. Other DBEs may be added to the list in accordance with the owner's approved DBE

program. Credit toward the DBE goal will not be counted unless the DBE to be used can be certified by the owner.

9. **CONTRACTOR'S REQUIRED SUBMISSION** - The owner requires the submission of the following information with the bid:

DISADVANTAGED BUSINESS ENTERPRISE PROGRAM

MBE's

MBE Subcontractors Names/Addresses/ Identity	Subcontract Work Item	Dollar Value of Subcontract Work
_____	_____	_____
_____	_____	_____
_____	_____	_____

WBE's

Women Subcontractors Names/Addresses/ Identity	Subcontract Work Item	Dollar Value of Subcontract Work
_____	_____	_____
_____	_____	_____
_____	_____	_____

OSE's

Other Socially and Economically Disadvantaged Subcontractors within the DBE Group Names/Addresses/ Identity	Subcontract Work Item	Dollar Value of Subcontract Work
_____	_____	_____
_____	_____	_____
_____	_____	_____

Total Dollar Value of Subcontract Work	_____
Total Dollar Value of Basic Bid	_____
Total DBE Percent	_____ %

*(Black, Hispanic, Asian American, American Indian, and other economically disadvantaged.)

If the Contractor fails to meet the contract goal established in Section 7 above, the following information must be submitted prior to contract award to assist the owner in determining whether or not the contractor made acceptable good faith efforts to meet the contract goal. This information (when applicable), as well as the DBE information, should be submitted as specified in Section 9 above.

Suggested guidance for use in determining if good faith efforts were made by a contractor are included in 49 CFR Part 26.

A list of the efforts that a contractor may make and the owner may use in making a determination as to the acceptability of a contractor's efforts to meet the goal as included in 49 CFR Part 26 are as follows:

- a. Whether the contractor attended any pre-solicitation or pre-bid meetings that were scheduled by the recipient to inform DBE's of contracting and subcontracting opportunities;
- b. Whether the contractor advertised in general circulation, trade association, and minority-focus media concerning the subcontracting opportunities;
- c. Whether the contractor provided written notice to a reasonable number of specific DBE's that their interest in the contract was being solicited in sufficient time to allow the DBE's to participate effectively;
- d. Whether the contractor followed up initial solicitations of interest by contacting DBE's to determine with certainty whether the DBE's were interested;
- e. Whether the contractor selected portions of work to be performed by DBE's in order to increase the likelihood of meeting the DBE goal (including, where appropriate, breaking down contracts into economically feasible units to facilitate DBE participation);
- f. Whether the contractor provided interested DBE's with adequate information about the plans, specifications, and requirements of the contract;
- g. Whether the contractor negotiated in good faith with interested DBE's, not rejecting DBE's as unqualified without sound reasons based on a thorough investigation of their capabilities.
- h. Whether the contractor made efforts to assist interested DBE's in obtaining bonding, lines of credit, or insurance required by the recipient or contractor;

and
- i. Whether the contractor effectively used the services of available minority community organizations; minority contractors' groups; local and state Federal Minority Business Assistance Offices; and other organizations that provide assistance in the recruitment and placement of DBE's.

NOTE: The nine items set forth above are merely suggested criteria and the owner may specify that you submit information on certain other actions a contractor took to secure DBE participation in an effort to meet the goals. A contractor may also submit to the owner other information on efforts to meet the goals.

CONTRACTOR ASSURANCE - The bidder hereby assures that he will meet one of the following as appropriate:

- a. The DBE participation goal as established in the General Conditions.
- b. The DBE participation percentage as shown in Section 9, which was submitted as a condition of contract award.

Agreements between bidder/proposer and a DBE in which the DBE promises not to provide subcontracting quotations to other bidders/proposers are prohibited. The bidder shall make a good faith effort to replace a DBE subcontract that is unable to perform successfully with another DBE subcontractor. Substitution must be coordinated and approved by the owner.

The bidder shall establish and maintain records and submit regular reports, as required, which will identify and assess progress in achieving DBE subcontract goals and other DBE affirmative action efforts.

11. PROMPT PAYMENT - The prime contractor agrees to pay each subcontractor under this prime contract for satisfactory performance of its contract no later than **10** days from the receipt of each payment the prime contractor receives from the owner. The prime contractor agrees further to return retainage payments to each subcontractor within **10** days after the subcontractor's work is satisfactorily completed. Any delay or postponement of payment from the above referenced time frame may occur only for good cause following written approval of the owner. This clause applies to both DBE and non-DBE subcontractors.

DBE CERTIFICATE OF COMPLIANCE FORM

The Florida Department of Transportation maintains an online searchable database of DBE firms at (<https://www3.dot.state.fl.us/equalopportunityoffice/biznet>).

Okaloosa County intends to utilize and implement this program in the awarding of this contract.

This is to certify that I have reviewed the plan, bid evaluation procedure, and DBE directory and will make all reasonable efforts to include DBE Contractors as outlined in pages OC-8 through OC-11.

Contractor's Signature

Date

Title

Notary Public

PERFORMANCE OF WORK BY SUBCONTRACTORS

The CONTRACTOR hereby states that he proposes, if awarded the Contract, to use the following subcontractors on this project: List below all proposed subcontractors and trade specialties. (List only one subcontractor for each item.)

	<u>Items of Work (Describe)</u>	Subcontractors
1
2
3
4
5
6
7
8
9
10
11
12
13
14
15

Estimated Total Cost of Items that CONTRACTOR states will be performed by Subcontractor:

(\$ _____)

E-VERIFY COMPLIANCE CERTIFICATION

In accordance with Okaloosa County Policy and Executive Order Number 11-116 from the office of the Governor of the State of Florida, Bidder hereby certifies that the U.S. Department of Homeland Security's E-Verify system will be used to verify the employment eligibility of all new employees hired by the contractor during the contract term, and shall expressly require any subcontractors performing work or providing services pursuant to the contract to likewise utilize the U.S. Department of Homeland Security's E-Verify system to verify the employment eligibility of all new employees hired by the subcontractor during the contract term; and shall provide documentation of such verification to the OWNER upon request.

As the person authorized to sign this statement, I certify that this company complies/will comply fully with the above requirements.

DATE: _____ SIGNATURE: _____

COMPANY: _____ NAME: _____
(Typed or Printed)

ADDRESS: _____ TITLE: _____

E-MAIL: _____

PHONE NO.: _____

CONE OF SILENCE

The Board of County Commissioners have established a solicitation silence policy (**Cone of Silence**) that prohibits oral and written communication regarding all formal solicitations for goods and services (ITB, RFP, ITQ, ITN, and RFQ) or other competitive solicitation between the bidder (or its agents or representatives) or other entity with the potential for a financial interest in the award (or their respective agents or representatives) regarding such competitive solicitation, and any County Commissioner or County employee, selection committee member or other persons authorized to act on behalf of the Board including the County's Architect, Engineer or their subconsultants, or anyone designated to provide a recommendation to award a particular contract, other than the Purchasing Department Staff..

The period commences from the time of advertisement until contract award.

Any information thought to affect the committee or staff recommendation submitted after bids are due, should be directed to the Purchasing Manager or an appointed representative. It shall be the Purchasing Manager's decision whether to consider this information in the decision process.

Any violation of this policy shall be grounds to disqualify the respondent from consideration during the selection process.

All respondents must agree to comply with this policy by signing the following statement and including it with their submittal.

I _____ (Signature) representing _____ (Company Name) on this _____ day of _____, 2020 hereby agree to abide by the County's "Cone of Silence Clause" and understand violation of this policy shall result in disqualification of my proposal/submittal.

BUY AMERICAN CERTIFICATE

Except for those items listed by the Bidder below or on a separate and clearly identified attachment to this Bid, the Bidder hereby certifies that steel and each manufactured product, is produced in the United States and that components of unknown origin are considered to have been produced or manufactured outside the United States.

PRODUCT

COUNTRY OF ORIGIN

(Name of Bidder)

By: _____

Title: _____

Dated: _____

LOBBYING- 31 U.S.C. 1352, 49 CFR PART 19, 49 CFR PART 20

APPENDIX A, 49 CFR PART 20—CERTIFICATION REGARDING LOBBYING

Certification for Contracts, Grants, Loans, and Cooperative Agreements

The undersigned (Contractor) certifies, to the best of his or her knowledge and belief, that:

1. No Federal appropriated funds have been paid or will be paid, by or on behalf of the undersigned, to any person for influencing or attempting to influence an officer or employee of an agency, a Member of Congress, an officer or employee of Congress, or an employee of a Member of Congress in connection with the awarding of any Federal contract, the making of any Federal grant, the making of any Federal loan, the entering into of any cooperative agreement, and the extension, continuation, renewal, amendment, or modification of any Federal contract, grant, loan, or cooperative agreement.

2. If any funds other than Federal appropriated funds have been paid or will be paid to any person for making the lobbying contacts to an officer or employee of any agency, a Member of Congress, an officer or employee of Congress, or an employee of a Member of Congress in connection with this Federal contract, grant, loan, or cooperative agreement, the undersigned shall complete and submit Standard Form—LLL, "Disclosure Form to Report Lobbying," in accordance with its instructions [as amended by "Government wide Guidance for New Restrictions on Lobbying," 61 Fed. Reg. 1413 (1/19/96). Note: Language in paragraph (2) herein has been modified in accordance with Section 10 of the Lobbying Disclosure Act of 1995 (P.L. 104-65, to be codified at 2 U.S.C. 1601, et seq.)]

3. The undersigned shall require that the language of this certification be included in the award documents for all subawards at all tiers (including subcontracts, subgrants, and contracts under grants, loans, and cooperative agreements) and that all subrecipients shall certify and disclose accordingly. This certification is a material representation of fact upon which reliance was placed when this transaction was made or entered into. Submission of this certification is a prerequisite for making or entering into this transaction imposed by 31, U.S.C. 1352 (as amended by the Lobbying Disclosure Act of 1995). Any person who fails to file the required certification shall be subject to a civil penalty of not less than \$10,000 and not more than \$100,000 for each such failure.

[Note: Pursuant to 31 U.S.C. 1352(c)(1)-(2)(A), any person who makes a prohibited expenditure or fails to file or amend a required certification or disclosure form shall be subject to a civil penalty of not less than \$10,000 and not more than \$100,000 for each such expenditure or failure.]

The Contractor, _____, certifies or affirms the truthfulness and accuracy of each statement of its certification and disclosure, if any. In addition, the Contractor understands and agrees that the provisions of 31 U.S.C. A 3801, *et seq*, apply to this certification and disclosure, if any.

_____ Signature of Contractor's Authorized Official

_____ Name and Title of Contractor's Authorized Official

_____ Date

EQUAL EMPLOYMENT OPPORTUNITY REPORT STATEMENT

Section 60-1.7(b) of the Regulations of the Secretary of Labor requires each bidder or prospective prime Contractor and proposed Subcontractor, where appropriate, to state in the bid or at the outset of negotiations for the Contract whether it has participated in any previous Contract or Subcontract subject to the equal opportunity clause; and if so, whether it has filed with the Joint Reporting Committee, the Director, an agency, or the former President’s Committee on Equal Employment Opportunity all reports due under the applicable filing requirements. In any case in which a bidder or prospective prime Contractor or proposed Subcontractor which participated in a previous Contract subject to Executive Order 10925, 11114 or 111246 has not filed a report due under the applicable filing documents, no Contract or Subcontract shall be awarded unless such Contractor submits a report covering the delinquent period or such other period specified by the FAA or the Director, OFCCP.

The Bidder (Proposer) shall complete the following statement by checking the appropriate boxes. Failure to complete these blanks may be grounds for rejection of bid.

1. The Bidder (Proposer) has (___) has not (___) developed and has on file at each establishment Affirmative Action Programs pursuant to 41 CFR 60-1.4 and 41 CFR 60-2.
2. The Bidder (Proposer) has (___) has not (___) participated in any previous Contract or Subcontract subject to the Equal Opportunity Clause prescribed by Executive Order 10925, or Executive Order 111114, or Executive Order 11246.
3. The Bidder (Proposer) has (___) has not (___) filed with the Joint Reporting Committee the annual compliance report on Standard Form 100 (EEO-1 Report).
4. The Bidder (Proposer) has (___) has not (___) submitted all compliance reports in connection with any such Contract due under the application filing requirements; and that representations indicating submission of required compliance reports signed by proposed Subcontractors will be obtained prior to award of Subcontractors.
5. The Bidder (Proposer) does (___) does not (___) employ fifty (50) or more employees.

If the Bidder (Proposer) has participated in a previous Contract subject to the equal opportunity clause and has not submitted compliance reports due under applicable filing requirements, the Bidder (Proposer) shall submit a compliance report on Standard Form 100. “Employee Information EEO-1” prior to the award of Contract.

Standard Form 100 is normally furnished to Contractors annually, based on a mailing list currently maintained by the Joint Reporting Committee. In the event a Contractor has not received the form, he may obtain it by writing to the following address: Joint Reporting Committee, 1800 G Street, Washington, D.C. 20506.

(Name of Bidder)

By: _____
Signature

Title: _____
Title

Date: _____

*Must be the same signature on Bid Proposal

CONTRACT FORMS



BID DOCUMENTS
VPS FUEL FARM FALL PROTECTION

STANDARD FORM OF AGREEMENT

THIS AGREEMENT is dated as of the _____ day of _____ in the year 2020 by and between The Board of County Commissioners of Okaloosa County, Florida (hereinafter called Owner) and _____ (hereinafter called Contractor).

Owner and Contractor, in consideration of the mutual covenants hereinafter set forth, agree as follows:

Article 1. WORK.

Contractor shall complete all Work as specified or indicated in the Contract Documents. The Work is generally described as follows:

VPS FUEL FARM FALL PROTECTION

Article 2. ENGINEER.

The Project has been designed by

AVCON, INC.

who is hereinafter called Engineer and who is to act as Owner's representative, assume all duties and responsibilities and have the rights and authority assigned to Engineer in the Contract Documents in connection with completion of the Work in accordance with the Contract Documents.

Article 3. CONTRACT TIMES.

3.1 The Work will be substantially completed within **120** calendar days after the date when the Contract Times commence to run as provided in paragraph 2.3 of the General Conditions, and completed and ready for final payment in accordance with paragraph 14.13 of the General Conditions within **140** calendar days after the date when the Contract Times commence to run.

3.2 *Liquidated Damages.* Owner and Contractor recognize that time is of the essence of this Agreement and that Owner will suffer financial loss if the Work is not completed within the times specified in paragraph 3.1 above, plus any extensions thereof allowed in accordance with Article 12 of the General Conditions. They also recognize the delays, expense and difficulties involved in proving the actual loss suffered by Owner if the Work is not completed on time. Accordingly, instead of requiring of such proof, Owner and Contractor agree that as liquidated damages for delay (but not as a penalty) Contractor shall pay Owner the amount specified in Paragraph 3.3 for each day that expires after the time specified in paragraph 3.1 for Substantial Completion until the Work is substantially complete. After Substantial Completion, if Contractor shall neglect, refuse, or fail to complete the remaining Work within the time specified in paragraph 3.1 for completion and readiness for final payment or any proper extension thereof granted by Owner, Contractor shall pay Owner the amount specified in Paragraph 3.3 for each day that expires after the time specified in paragraph 3.1 for completion and readiness for final payment. The Contractor hereby expressly waives and relinquishes any right which it may have to seek to characterize the liquidated damages as a penalty, which the parties agree represents a fair and reasonable estimate of the Owner's actual damages at the time of contracting if the Contractor fails to substantially complete the Work in a timely manner.

3.3.1 Liquidated Damages are based upon the original contract amount, as established by Okaloosa County. Liquidated damages, based upon the original contract amount of \$_____, will be dollars (\$_____) per calendar day.

Article 4. CONTRACT PRICE.

Owner shall pay Contractor for completion of the Work in accordance with the Contract Documents an amount in current funds equal to the sum of the established unit price for each separately identified item of Unit Price Work times the estimated quantity of that item as indicated in the Bid Schedule submitted in the Bid Form. The cost of this project is \$_____ as per the attached Contractor bid.

As provided in paragraph 11.9 of the General Conditions estimated quantities are not guaranteed, and determinations of actual quantities and classification are to be made by Engineer as provided in paragraph 9.10 of the General Conditions. Unit prices have been computed as provided in paragraph 11.9.2 of the General Conditions.

Article 5. PAYMENT PROCEDURES

Contractor shall submit Application for Payment in accordance with Article 14 of the General Conditions. Applications for Payment will be processed by Engineer as provided in the General Conditions.

5.1 *Progress Payments; Retainage.* Owner shall make progress payments on account of the Contract Price on the basis of Contractor's Applications for Payment as recommended by Engineer, on or about the fifteenth (15th) day of each month during construction as provided in paragraphs 5.1.1 and 5.1.2 below. All such payments will be measured based on the number of units completed. Payments to the Contractor shall in no way imply approval or acceptance of Contractor's work.

5.1.1 Prior to Substantial completion, payments will be made in an amount equal to the percentage indicated below, but, in each case, less the aggregate of payments previously made and less such amounts as Engineer shall determine, or Owner may withhold, in accordance with paragraph 14.7 of the General Conditions.

90 % of Work completed (with the balance being retainage). Once the Contractor completes at least 50% of the Work based on approved pay applications, the retainage will be reduced from 10% to 5% for the remainder of the project. Therefore, following completion of at least 50% of the Work, the Contractor may be paid 95 % of Work completed (with the balance being retainage).

90 % (with the balance being retainage) of materials and equipment not incorporated in the Work (but delivered, suitably stored and accompanied by documentation satisfactory to Owner as provided in paragraph 14.2 of the General Conditions). Once the Contractor completes at least 50% of the Work based on approved pay applications, the retainage will be reduced from 10% to 5% for the remainder of the project. Therefore, following completion of at least 50% of the Work, the Contractor may be paid 95 % of materials and equipment not incorporated in the Work (but delivered, suitably stored and accompanied by documentation satisfactory to Owner as provided in paragraph 14.2 of the General Conditions).

5.1.2 Upon Substantial Completion, in an amount sufficient to increase total payments to Contractor to 95 % of the Contract Price (with the balance being retainage), less such amounts as Engineer shall determine, or Owner may withhold, in accordance with paragraph 14.7 of the General Conditions.

5.1.3 Retainage requirements may be changed to reflect a proposed change to state regulatory statutes.

5.2 *Final Payment.* Upon final completion and acceptance of the Work in accordance with paragraph 14.13 of the General Conditions, Owner shall pay the remainder of the Contract Price as recommended by Engineer as provided in said paragraph 14.13.

5.2.1 Contractor's acceptance of final payment shall constitute a full waiver of any and all claims by Contractor against the County arising out of this Agreement or otherwise relating to the Project, except those previously made in writing and identified by Contractor as unsettled at the time of the final Application for Payment. Neither the acceptance of the Work nor payment by the County shall be deemed to be a waiver of the County's right to enforce any obligations of the Contractor hereunder or to the recovery of damages for defective Work not discovered by the Engineer or the County at the time of final inspection.

5.3 Payments Withheld

5.3.1 The Engineer or the County may decline to approve any Applications for Payment, or portions thereof, because of subsequently discovered evidence or subsequent inspections. The Engineer or the County may nullify the whole or any part of any inspections. The Engineer or the County may nullify the whole or any part of any approval for payment previously issued and the County may withhold any payments otherwise due Contractor under this Agreement or any other agreement between the County and the Contractor, to such extent as may be necessary in the County's opinion to protect it from loss because of:

5.3.1.1 Defective Work not remedied;

5.3.1.2 Third party claims filed or reasonable evidence indicating probable filing of such claims;

5.3.1.3 Failure of Contractor to make payment properly to subcontractors or for labor, materials or equipment;

5.3.1.4 Reasonable doubt that the Work can be completed for the unpaid balance of the Contract Amount;

5.3.1.5 Reasonable indication that the Work will not be completed within the Contract Time;

5.3.1.6 Unsatisfactory prosecution of the Work by the Contractor;

5.3.1.7 Failure to provide accurate and current "As-Builts"; or

5.3.1.8 Any other material breach of the Contract Documents.

5.3.2 If these conditions in Subsection 5.3.1 are not remedied or removed, the County may after three (3) days written notice, rectify the same at Contractor's expense. The County also may offset against any sums due Contractor the amount of any liquidated or unliquidated obligations of Contractor to the County, whether relating to or arising out of his Agreement or any other agreement between Contractor and the County.

Article 6. CONTRACTOR'S REPRESENTATIONS.

In order to induce Owner to enter into this Agreement Contractor makes the following representations:

6.1 Contractor has examined and carefully studied the Contract Documents (including the Addenda listed in Article 7) and the other related data identified in the Project Documents including "technical data."

6.2 Contractor has visited the site and become familiar with and is satisfied as to the general, local, and site conditions that may affect cost, progress, performance or furnishing of the Work.

6.3 Contractor is familiar with and is satisfied as to all federal, state, and local Laws and Regulations that may affect cost, progress, performance and furnishing of the Work.

6.4 Contractor has carefully studied all reports of explorations and tests of subsurface conditions at or contiguous to site and all drawings of physical conditions in or relating to existing surface or subsurface structures at or contiguous to the site (except Underground Facilities) which have been identified in the Supplementary Conditions as provided in paragraph 4.2.1 of the General Conditions. Contractor accepts the determination of the extent of the "technical data" contained in such reports and drawings upon which Contractor is entitled to rely as provided in paragraph 4.2 of the General Conditions. Contractor acknowledges that such reports and drawings are not Contract Documents and may not be complete for Contractor's purposes. Contractor acknowledges that Owner and Engineer do not assume responsibility for the accuracy or completeness of information and data shown or indicated in the Contract Documents with respect to Underground Facilities at or contiguous to the site. Contractor has obtained and carefully studied (or assumes responsibility for having done so) all such additional supplementary examinations, investigations, explorations, tests, studies, and data concerning conditions (surface, subsurface, and Underground Facilities) at or contiguous to the site or otherwise which may affect cost, progress, performance, or furnishing of the Work or which relate to any aspect of the means, methods, techniques, sequences, and procedures of construction to be employed by Contractor and safety precautions, and programs incident thereto. Contractor does not consider that any additional examinations, investigations, explorations, tests, studies, or data are necessary for the performance and furnishing of the Work at the Contract Price, within the Contract Times and in accordance with the other terms and conditions of the Contract Documents.

6.5 Contractor is aware of the general nature of work to be performed by Owner and others at the site that relates to the Work as indicated in the Contract Documents.

6.6 Contractor has correlated the information known to Contractor, information and observation obtained from visits to the site, reports, and drawings identified in the Contract Documents and all additional examinations, investigations, explorations, tests, studies, and data with the Contract Documents.

6.7 Contractor has given Engineer written notice of all conflicts, errors, ambiguities or discrepancies that Contractor has discovered in the Contract Documents and the written resolution thereof by Engineer is acceptable to Contractor, and the Contract Documents are generally sufficient to indicate and convey understanding of all terms and conditions for performance and furnishing of the Work.

Article 7. CONTRACT DOCUMENTS

The Contract Documents that comprise the entire agreement between Owner and Contractor concerning the Work consist of the following:

- 7.1 This Agreement (pages SFA-1 to SFA-8, inclusive)
- 7.2 Performance, Payment, and other Bonds
- 7.3 Okaloosa County Standard Clauses (pages SACC-1 to SACC-6, inclusive)
- 7.4 General Conditions (pages GC-1 to GC-58, inclusive)
- 7.5 Drawings consisting of a cover sheet and sheets numbered T-001, S-001 through S-201 with each sheet bearing the following general title:

VPS FUEL FARM FALL PROTECTION

- 7.6 Addenda numbers __ to __, inclusive
- 7.7 Contractor's Bid (pages __ to __ and __ to __ inclusive)
- 7.8 Documentation submitted by Contractor prior to Notice of Award
- 7.9 The following which may be delivered or issued after the Effective Date of the Agreement and are not attached hereto:

All Written Amendments and other documents amending, modifying or supplementing the Contract Documents pursuant to paragraphs 3.5 and 3.6 of the General Conditions

The documents listed in paragraph 7.2 et seq. above are attached to this Agreement (except as expressly noted otherwise above).

There are not Contract Documents other than those listed above in this Article 7. The Contract Documents may only be amended, modified or supplemented as provided in paragraphs 3.5 and 3.6 of the General Conditions.

Article 8. PUBLIC RECORDS

Any record created by either party in accordance with this Contract shall be retained and maintained in accordance with the public records law, Florida Statutes, Chapter 119.

IF THE CONSULTANT HAS QUESTIONS REGARDING THE APPLICATION OF CHAPTER 119, FLORIDA STATUTES, TO THE CONTRACTOR'S DUTY TO PROVIDE PUBLIC RECORDS RELATING TO THIS CONTRACT, CONTACT THE CUSTODIAN OF

**PUBLIC RECORDS AT OKALOOSA COUNTY RISK MANAGEMENT DEPARTMENT
5479 OLD BETHEL ROAD CRESTVIEW, FL 32536 PHONE: (850) 689-5977
riskinfo@co.okaloosa.fl.us.**

Consultant must comply with the public records laws, Florida Statute chapter 119, specifically Consultant must:

8.1 Keep and maintain public records required by the County to perform the service.

8.2 Upon request from the County's custodian of public records, provide the County with a copy of the requested records or allow the records to be inspected or copied within a reasonable time at a cost that does not exceed the cost provided in chapter 119 Florida Statutes or as otherwise provided by law.

8.3 Ensure that public records that are exempt or confidential and exempt from public records disclosure requirements are not disclosed except as authorized by law for the duration of the contract term and following completion of the contract if the consultant does not transfer the records to the County.

8.4 Upon completion of the contract, transfer, at no cost, to the County all public records in possession of the contractor or keep and maintain public records required by the County to perform the service. If the consultant transfers all public records to the public agency upon completion of the contract, the consultant shall destroy any duplicate public records that are exempt or confidential and exempt from public records disclosure requirements. If the consultant keeps and maintains public records upon completion of the contract, the consultant shall meet all applicable requirements for retaining the public records. All records stored electronically must be provided to the public agency, upon the request from the public agency's custodian of public records, in a format that is compatible with the information technology systems of the public agency.

Article 9. AUDIT

The County and/or its designee shall have the right from time to time at its sole expense to audit the compliance by the Contractor with the terms, conditions, obligations, limitations, restrictions, and requirements of this Contract and such right shall extend for a period of three (3) years after termination of this Contract.

Article 10. TERMINATION FOR CONVENIENCE

Owner may at any time and for any reason terminate Contractor's services and work at Owner's convenience. Upon receipt of such notice, Contractor shall, unless the notice directs otherwise, immediately discontinue the work and placing of orders for materials, facilities and supplies in connection with the performance of this Agreement.

Upon such termination, Contractor shall be entitled to payment only as follows: (1) the actual cost of the work completed in conformity with this Agreement; plus, and (2) such other costs actually incurred by Contractor as are permitted by the prime contract and approved by Owner. There shall be deducted from such sums as provided in this subparagraph the amount of any payments made to Contractor prior to the date of the termination of this Agreement. Contractor shall not be entitled to any claim or claim

of lien against Owner for any additional compensation or damages in the event of such termination and payment. Further, Owner may terminate this contract immediately for failure of contractor to comply with Chapter 119, Florida Statutes.

Article 11. VIOLATIONS OF CHAPTER 119 FLORIDA STATUTES

The County reserves the right to terminate this agreement immediately for failure of Contractor to adhere to the requirements of Florida Statutes Chapter 119.

Article 12. MISCELLANEOUS.

12.1 Terms used in this Agreement which are defined in Article 1 of the General Conditions will have the meanings indicated in the General Conditions.

12.2 No assignment by a party hereto of any rights under or interests in the Contract Documents will be binding on another party hereto without the written consent of the party sought to be bound; and, specifically but without limitation, moneys that may become due and moneys that are due may not be assigned without such consent (except to the extent that the effect of this restriction may be limited by law), and unless specifically stated to the contrary in any written consent to an assignment no assignment will release or discharge the assignor from any duty or responsibility under the Contract Documents.

12.3 Owner and Contractor each binds itself, its partners, successors, assigns and legal representatives to the other party hereto, its partners, successors, assigns and legal representatives in respect to all covenants, agreements, and obligations contained in the Contract Documents.

12.4 Any provisions or part of the Contract Documents held to be void or unenforceable under any Law or Regulation shall be deemed stricken, and all remaining provisions shall continue to be valid and binding upon Owner and Contractor, who agree that the Contract Documents shall be reformed to replace such stricken provision or part thereof with a valid and enforceable provision that comes as close as possible to expressing the intention of the stricken provision.

IN WITNESS WHEREOF, Owner, and Contractor have signed this Agreement in triplicate. One counterpart each has been delivered to Owner, Contractor, and Engineer. All portions of the Contract Documents have been signed, initialed or identified by Owner, and Contractor, or identified by Engineer on their behalf.

This Agreement will be effective on _____, 2020 (which is the Effective Date of the Agreement).

Article 13. INCORPORATION OF DOCUMENTS

OWNER

CONTRACTOR

Okaloosa County, Florida _____

Chairman, Board of County Commissioners

Attest

Attest

J.D. Peacock II
Clerk of Circuit Court

Address for giving notices

Address for giving notices

(If Owner is a public body, attached evidence of authority to sign and resolution or other documents authorizing execution of Agreement).

License No. _____

Agent for services of process: _____

If Contractor is a corporation, attach evidence of authority to sign).

PERFORMANCE BOND

KNOW ALL MEN by these presents; That we (1) _____
_____ a (2) _____
hereinafter called "Principal" and (3) _____
of _____, State of _____, hereinafter called the
"Surety", are held and firmly bound unto (4) _____
of _____, hereinafter called "OWNER", in the penal sum
of _____ dollars (\$ _____)
in lawful money of the United States for the payment of which sum well and truly to be made, we bind
ourselves, our heirs, executors, administrators and successors, jointly and severally, firmly by these
presents.

THE CONDITION OF THIS OBLIGATION is such that whereas, the Principal entered into a certain
contract with the Owner, dated the ___ day of _____, 20___, a copy of which is hereto
attached and make a part hereof for the construction of:

VPS FUEL FARM FALL PROTECTION

NOW, THEREFORE, if the Principal shall well, truly and faithfully perform its duties, all the
undertakings, covenants, terms, conditions, and agreements of said contract during the original
term thereof, and any extensions thereof which may be granted by the Owner, with or without
notice to the Surety, and if he shall satisfy all claims and demands incurred under such contract,
and shall fully indemnify and save harmless the Owner from all costs and damages which it may
suffer by reason of failure to do so, and shall reimburse and repay the Owner all outlay and
expense which the Owner may incur in making good any default, then this obligation shall be
void; otherwise to remain in full force and effect.

PROVIDED, FURTHER, that the said Surety, for value received hereby stipulates and agrees that
no change, extension of time, alteration or addition to the terms of the contract or to the work
to be performed thereunder or the Specifications accompanying the same shall in any way
affect its obligations on this bond, and it does not hereby waive notice of any such change,
extension of time, alteration or addition to the terms of the contract or to the work or to the
Specifications.

PROVIDED, FURTHER, that no final settlement between the Owner and the Contractor shall abridge the right of any beneficiary hereunder, whose claim may be unsatisfied.

IN WITNESS WHEREOF, this instrument is executed in six (6) counterparts, each one of which shall be deemed an original, this the _____ day of _____, 20__.

ATTEST:

(Principal) Secretary

Witness as to Surety

Address

Principal

By: _____

Address

SEAL:

ATTEST:

(Surety) Secretary

Witness as to Surety

Address

Surety

Attorney-in-Fact

Address

SEAL:

Date of bond must not be prior to date of Contract

1. Correct name of Contractor.
2. A Corporation, A Partnership or an Individual as case may be.
3. Correct name of Surety.
4. Correct name of Owner.
5. If Contractor is Partnership, all partners should execute bond.

PAYMENT BOND

KNOW ALL MEN by these presents; That we (1) _____
_____ a (2) _____
hereinafter called "Principal" and (3) _____
of _____, State of _____, hereinafter call the
"Surety", are held and firmly bound unto (4) _____
of _____ State of Florida _____, hereinafter called "OWNER", in the penal sum of _____
_____ dollars (\$ _____) in lawful money
of the United States for the payment of which sum well and truly to be made, we bind ourselves, our
heirs, executors, administrators and successors, jointly and severally, firmly by these presents.

THE CONDITION OF THIS OBLIGATION is such that Whereas, the Principal entered into a certain contract
with the Owner, dated the ____ day of _____, 20__, a copy of which is hereto
attached and make a part hereof for the construction of:

VPS FUEL FARM FALL PROTECTION

NOW, THEREFORE, if the Principal shall promptly make payments to all persons, firms, subcontractors,
and corporations furnishing materials for or performing labor in the prosecution of the work provided
for in such contract, and any authorized extension or modification thereof, including all amounts due for
materials, lubricants, oil, gasoline, coal and coke, repairs on machinery, equipment and tools, consumed
or used in connection with the construction of such work, and all insurance premiums on said work, and
for all labor, performed in such work, whether by subcontractor or otherwise, then this obligation shall
be void; otherwise to remain in full force and effect.

PROVIDED, FURTHER, that the said Surety, for value received hereby stipulates and agrees that no change, extension of time, alteration or addition to the terms of the contract or to the work to be in any wise affect its obligation on this bond, and it does hereby waive notice of any such changes, extension of time, alteration or addition to the terms of the contractor or to the work or to the Specifications.

PROVIDED, FURTHER, that no final settlement between the Owner and the Contractor shall abridge the right of any beneficiary hereunder, whose claim may be unsatisfied.

IN WITNESS WHEREOF, this instrument is executed in six (6) counterparts, each one of which shall be deemed an original, this the _____ day of _____, 20__.

ATTEST:

(Principal) Secretary

Witness as to Surety

Address

By:

Principal

SEAL:

ATTEST:

(Surety) Secretary

Witness as to Surety

Address

Surety

Attorney-in-Fact

SEAL:

Address

CONTRACTOR'S RELEASE OF LIENS

STATE OF: _____

COUNTY OF: _____

Before me, the undersigned Notary Public in and for the said County and State personally appeared _____, representing the Contractor _____, who being duly sworn according to law deposes and says that all labor, materials, and outstanding claims and indebtedness of whatever nature arising out of the performance of the Contract with _____, the Owner, for _____, Contract No. _____, have been paid in full and that for the final payment in the amount of \$ _____, the Contractor releases and discharges the Owner and his authorized representatives from any liens or claims or any nature because of or arising from this Contract and/or its performance, which it has had, has or may have in the future.

By: _____

Sworn to and subscribed before me this

_____ day of _____

(Notary Public)

My Commission Expires: _____

ADVERTISEMENT OF COMPLETION

_____ (Contractor)

_____ (Address)

gives notice of completion of _____ (Project)

and sets _____ as the date of final settlement.

All persons and firms should file all claims for payment to the below address prior to the settlement date:

Okaloosa County
5479A Old Bethel Road
Crestview, FL 32536

By: _____ (Name)

_____ (Title)

Leg: _____ (Publication Dates)

Title VI Clauses for Compliance with Nondiscrimination Requirements

Compliance with Nondiscrimination Requirements

During the performance of this contract, the contractor, for itself, its assignees, and successors in interest (hereinafter referred to as the “contractor”) agrees as follows:

1. **Compliance with Regulations:** The contractor (hereinafter includes consultants) will comply with the Title VI List of Pertinent Nondiscrimination Acts And Authorities, as they may be amended from time to time, which are herein incorporated by reference and made a part of this contract.
2. **Non-discrimination:** The contractor, with regard to the work performed by it during the contract, will not discriminate on the grounds of race, color, or national origin in the selection and retention of subcontractors, including procurements of materials and leases of equipment. The contractor will not participate directly or indirectly in the discrimination prohibited by the Nondiscrimination Acts and Authorities, including employment practices when the contract covers any activity, project, or program set forth in Appendix B of 49 CFR part 21.
3. **Solicitations for Subcontracts, Including Procurements of Materials and Equipment:** In all solicitations, either by competitive bidding, or negotiation made by the contractor for work to be performed under a subcontract, including procurements of materials, or leases of equipment, each potential subcontractor or supplier will be notified by the contractor of the contractor’s obligations under this contract and the Nondiscrimination Acts And Authorities on the grounds of race, color, or national origin.
4. **Information and Reports:** The contractor will provide all information and reports required by the Acts, the Regulations, and directives issued pursuant thereto and will permit access to its books, records, accounts, other sources of information, and its facilities as may be determined by the sponsor or the Federal Aviation Administration to be pertinent to ascertain compliance with such Nondiscrimination Acts And Authorities and instructions. Where any information required of a contractor is in the exclusive possession of another who fails or refuses to furnish the information, the contractor will so certify to the sponsor or the Federal Aviation Administration, as appropriate, and will set forth what efforts it has made to obtain the information.
5. **Sanctions for Noncompliance:** In the event of a contractor’s noncompliance with the Non-discrimination provisions of this contract, the sponsor will impose such contract sanctions as it or the Federal Aviation Administration may determine to be appropriate, including, but not limited to:
 - a. Withholding payments to the contractor under the contract until the contractor complies; and/or

- b. Cancelling, terminating, or suspending a contract, in whole or in part.
6. **Incorporation of Provisions:** The contractor will include the provisions of paragraphs one through six in every subcontract, including procurements of materials and leases of equipment, unless exempt by the Acts, the Regulations and directives issued pursuant thereto. The contractor will take action with respect to any subcontract or procurement as the sponsor or the Federal Aviation Administration may direct as a means of enforcing such provisions including sanctions for noncompliance. Provided, that if the contractor becomes involved in, or is threatened with litigation by a subcontractor, or supplier because of such direction, the contractor may request the sponsor to enter into any litigation to protect the interests of the sponsor. In addition, the contractor may request the United States to enter into the litigation to protect the interests of the United States.

Title VI List of Pertinent Nondiscrimination Acts and Authorities

Title VI List of Pertinent Nondiscrimination Acts and Authorities

During the performance of this contract, the contractor, for itself, its assignees, and successors in interest (hereinafter referred to as the “contractor”) agrees to comply with the following non-discrimination statutes and authorities; including but not limited to:

- Title VI of the Civil Rights Act of 1964 (42 U.S.C. § 2000d *et seq.*, 78 stat. 252), (prohibits discrimination on the basis of race, color, national origin);
- 49 CFR part 21 (Non-discrimination In Federally-Assisted Programs of The Department of Transportation—Effectuation of Title VI of The Civil Rights Act of 1964);
- The Uniform Relocation Assistance and Real Property Acquisition Policies Act of 1970, (42 U.S.C. § 4601), (prohibits unfair treatment of persons displaced or whose property has been acquired because of Federal or Federal-aid programs and projects);
- Section 504 of the Rehabilitation Act of 1973, (29 U.S.C. § 794 *et seq.*), as amended, (prohibits discrimination on the basis of disability); and 49 CFR part 27;
- The Age Discrimination Act of 1975, as amended, (42 U.S.C. § 6101 *et seq.*), (prohibits discrimination on the basis of age);
- Airport and Airway Improvement Act of 1982, (49 USC § 471, Section 47123), as amended, (prohibits discrimination based on race, creed, color, national origin, or sex);
- The Civil Rights Restoration Act of 1987, (PL 100-209), (Broadened the scope, coverage and applicability of Title VI of the Civil Rights Act of 1964, The Age Discrimination Act of 1975 and Section 504 of the Rehabilitation Act of 1973, by expanding the definition of the terms “programs or activities” to include all of the programs or activities of the Federal-aid recipients, sub-recipients and contractors, whether such programs or activities are Federally funded or not);

- Titles II and III of the Americans with Disabilities Act of 1990, which prohibit discrimination on the basis of disability in the operation of public entities, public and private transportation systems, places of public accommodation, and certain testing entities (42 U.S.C. §§ 12131 – 12189) as implemented by Department of Transportation regulations at 49 CFR parts 37 and 38;
- The Federal Aviation Administration’s Non-discrimination statute (49 U.S.C. § 47123) (prohibits discrimination on the basis of race, color, national origin, and sex);
- Executive Order 12898, Federal Actions to Address Environmental Justice in Minority Populations and Low-Income Populations, which ensures non-discrimination against minority populations by discouraging programs, policies, and activities with disproportionately high and adverse human health or environmental effects on minority and low-income populations;
- Executive Order 13166, Improving Access to Services for Persons with Limited English Proficiency, and resulting agency guidance, national origin discrimination includes discrimination because of limited English proficiency (LEP). To ensure compliance with Title VI, you must take reasonable steps to ensure that LEP persons have meaningful access to your programs (70 Fed. Reg. at 74087 to 74100);
- Title IX of the Education Amendments of 1972, as amended, which prohibits you from discriminating because of sex in education programs or activities (20 U.S.C. 1681 et seq).

FEDERAL FAIR LABOR STANDARDS ACT (FEDERAL MINIMUM WAGE)

All contracts and subcontracts that result from this solicitation incorporate by reference the provisions of 29 CFR part 201, the Federal Fair Labor Standards Act (FLSA), with the same force and effect as if given in full text. The FLSA sets minimum wage, overtime pay, recordkeeping, and child labor standards for full and part time workers.

The [*contractor / consultant*] has full responsibility to monitor compliance to the referenced statute or regulation. The [*contractor / consultant*] must address any claims or disputes that arise from this requirement directly with the U.S. Department of Labor – Wage and Hour Division

OCCUPATIONAL SAFETY AND HEALTH ACT OF 1970

All contracts and subcontracts that result from this solicitation incorporate by reference the requirements of 29 CFR Part 1910 with the same force and effect as if given in full text. Contractor must provide a work environment that is free from recognized hazards that may cause death or serious physical harm to the employee. The Contractor retains full responsibility to monitor its compliance and their subcontractor’s compliance with the applicable requirements of the Occupational Safety and Health Act of 1970 (20 CFR Part 1910). Contractor must address any claims or disputes that pertain to a referenced requirement directly with the U.S. Department of Labor – Occupational Safety and Health Administration.

E-VERIFY

Enrollment and verification requirements.

- (1) If the Contractor is not enrolled as a Federal Contractor in E-Verify at time of contract award, the Contractor shall-
 - a. Enroll. Enroll as a Federal Contractor in the E-Verify Program within thirty (30) calendar days of contract award;
 - b. Verify all new employees. Within ninety (90) calendar days of enrollment in the E-Verify program, begin to use E-Verify to initiate verification of employment eligibility of all new hires of the Contractor, who are working in the United States, whether or not assigned to the contract, within three (3) business days after the date of hire (but see paragraph (b)(3) of this section); and,
 - c. Verify employees assigned to the contract. For each employee assigned to the contract, initiate verification within ninety (90) calendar days after date of enrollment or within thirty (30) calendar days of the employee's assignment to the contract, whichever date is later (but see paragraph (b)(4) of this section.)
- (2) If the Contractor is enrolled as a Federal Contractor in E-Verify at time of contract award, the Contractor shall use E-Verify to initiate verification of employment eligibility of
 - a. All new employees.
 - i. Enrolled ninety (90) calendar days or more. The Contractor shall initiate verification of all new hires of the Contractor, who are working in the United States, whether or not assigned to the contract, within three (3) business days after the date of hire (but see paragraph (b)(3) of this section); or
 - ii. Enrolled less than ninety (90) calendar days. Within ninety (90) calendar days after enrollment as a Federal Contractor in E-Verify, the Contractor shall initiate verification of all new hires of the contractor, who are working in the United States, whether or not assigned to the contract, within three (3) business days after the date of hire (but see paragraph (b)(3) of this section); or
 - iii. Employees assigned to the contract. For each employee assigned to the contract, the Contractor shall initiate verification within ninety (90) calendar days after date of contract award or within thirty (30) days after assignment to the contract, whichever date is later (but see paragraph (b)(4) of this section.)
- (3) If the Contractor is an institution of higher education (as defined at 20 U.S.C. 1001(a)); a State of local government or the government of a Federally recognized Indian tribe, or a surety performing under a takeover agreement entered into with a Federal agency pursuant to a performance bond, the Contractor may choose to verify only employees assigned to the contract, whether existing employees or new hires. The Contractor shall

- follow the applicable verification requirements of (b)(1) or (b)(2), respectively, except that any requirement for verification of new employees applies only to new employees assigned to the contract.
- (4) Option to verify employment eligibility of all employees. The Contractor may elect to verify all existing employees hired after November 6, 1986 (after November 27, 2009, in the Commonwealth of the Northern Mariana Islands), rather than just those employees assigned to the contract. The Contractor shall initiate verification for each existing employee working in the United States who was hired after November 6, 1986 (after November 27, 2009, in the Commonwealth of the Northern Mariana Islands), within one hundred eighty (180) calendar days of-
- i. Enrollment in the E-Verify program; or
 - ii. Notification to E-Verify Operations of the Contractor's decision to exercise this option, using the contract information provided in the E-Verify program Memorandum of Understanding (MOU)
- (5) The Contractor shall comply, for the period of performance of this contract, with the requirements of the E-Verify program MOU.
- i. The Department of Homeland Security (DHS) or the Social Security Administration (SSA) may terminate the Contractor's MOU and deny access to the E-Verify system in accordance with the terms of the MOU. In such case, the Contractor, will be referred to a suspension or debarment official.
 - ii. During the period between termination of the MOU and a decision by the suspension or debarment official whether to suspend or debar, the contractor is excused from its obligations under paragraph (b) of this clause. If the suspension or debarment official determines not to suspend or debar the Contractor, then the Contractor must reenroll in E-Verify.
 - iii. Web site. Information on registration for and use of the E-Verify program can be obtained via the Internet at the Department of Homeland Security Web site: <http://www.dhs.gov/E-Verify>.
- Individuals previously verified. The Contractor is not required by this clause to perform additional employment verification using E-Verify for any employee-
- (a) Whose employment eligibility was previously verified by the Contractor through the E-Verify program;
 - (b) Who has been granted and holds an active U.S. Government security clearance for access to confidential, secret, or top secret information in accordance with the National Industrial Security Program Operating Manual; or

- (c) Who has undergone a completed background investigation and been issued credentials pursuant to Homeland Security Presidential Directive (HSPD)-12. Policy for a Common Identification Standard for Federal Employees and Contractors.

Subcontracts. The Contractor shall include the requirements of this clause, including this paragraph € (appropriately modified for identification of the parties in each subcontract that-

- (1) Is for-(i) Commercial and noncommercial services (except for commercial services that are part of the purchase of a COTS item (or an item that would be a COTS item, but for minor modifications), performed by the COTS provider, and are normally provided for that COTS item); or
 - (ii) Construction;
- (2) Has a value of more than \$3,500; and
- (3) Includes work performed in the United States.

GENERAL CONDITIONS



BID DOCUMENTS
VPS FUEL FARM FALL PROTECTION

GENERAL CONDITIONS

ARTICLE 1 – DEFINITIONS

Wherever used in these General Conditions or in the other Contract Documents the following terms have the meanings indicated which are applicable to both the singular and plural thereof:

- 1.1. AASHTO – The American Association of State Highway and Transportation Officials, the successor association AASHO.
- 1.2. Access Road – The right-of-way, the roadway and all improvements constructed thereon connecting the airport to a public highway.
- 1.3. Addenda – Written or graphic instruments issued prior to the opening of Bids which clarify, correct or change the Project Requirements or the Contract Documents.
- 1.4. Advertisement – A public announcement, as required by local law, inviting bids for work to be performed and materials to be furnished.
- 1.5. Agreement – The written contract between Owner and Contractor covering the Work to be performed; other Contract Documents are attached to the Agreement and made a part thereof as provided therein.
- 1.6. AIP – The Airport Improvement Program, a grant-in-aid program, administered by the Federal Aviation Administration.
- 1.7. Air Operations Area – For the purpose of these specifications, the term air operations area shall mean any area of the airport used or intended to be used for the landing, takeoff, or surface maneuvering of aircraft. An air operation area shall include such paved or unpaved areas that are used or intended to be used for the unobstructed movement of aircraft in addition to its associated runway, taxiway, or apron.
- 1.8. Airport – Airport means the area of land or water which is used or intended to be used for the landing and takeoff of aircraft, and includes its buildings and facilities, if any.
- 1.9. Application for Payment – The form accepted by Engineer which is to be used by Contractor in requesting progress or final payments and which is to be accompanied by such supporting documentation as is required by the Contract Documents.
- 1.10. Asbestos – Any material that contains more than one percent asbestos and is friable or is releasing asbestos fibers into the air above current action levels established by the United States Occupational Safety and Health Administration.
- 1.11. ASTM – The American Society for Testing and Materials.
- 1.12. Award – The acceptance, by the Owner, of the successful contractor's proposal.
- 1.13. Bid – The offer or proposal of the contractor submitted on the prescribed form setting forth the prices for the Work to be performed.

- 1.14. Contractor – Any individual, partnership, firm, or corporation, acting directly or through a duly authorized representative, who submits a proposal for the work contemplated.
- 1.15. Project Documents – The advertisement or invitation to Bid, instructions to contractors, the Bid Form, and the proposed Contract Documents (including all Addenda issued prior to receipt of Bids).
- 1.16. Project Requirements – The advertisement or invitation to Bid, instructions to contractors, and the Bid Form.
- 1.17. Building Area – An area on the airport to be used, considered, or intended to be used for airport buildings, or other facilities or rights-of-way together with all airport buildings and facilities located thereon.
- 1.18. Bonds – Performance and Payment bonds and other instruments of security.
- 1.19. Calendar Day – Every day shown on the calendar.
- 1.20. Certificates of Compliance – Written statements by the manufacturer stating the material furnished is in conformance with the Specifications.
- 1.21. Change Order – A document recommended by Engineer, which is signed by Contractor and Owner and authorizes an addition, deletion or revision in the Work, or an adjustment in the Contract Price or the Contract Times, issued on or after the Effective Date of the Agreement. The work covered by a change order shall be within the scope of the contract.
- 1.22. Contract Documents – The Agreement, Addenda (which pertain to the Contract Documents), Contractor's Bid (including documentation accompanying the Bid and any post Bid documentation submitted prior to the Notice of Award) when attached as an exhibit to the Agreement, the Notice to Proceed, the Bonds, these General Conditions, the Supplementary Conditions, the Specifications and the Drawings as the same are more specifically identified in the Agreement, together with all Written Amendments, Change Orders, Work Change Directives, Field Orders and Engineer's written interpretations and clarifications issued pursuant to paragraphs 3.5, 3.6.1, and 3.6.3 on or after the Effective Date of the Agreement. Shop Drawing submittals approved pursuant to paragraphs 6.19 and 6.20 and the reports and drawings referred to in paragraphs 4.2.1.1 and 4.2.2.2 are not Contract Documents.
- 1.23. Contract Price – The money payable by Owner to Contractor for completion of the Work in accordance with the Contract Documents as stated in the Agreement (subject to the provisions of paragraph 11.9.1 in the case of Unit Price Work).
- 1.24. Contract Times – The numbers of days or the dates stated in the Agreement: (i) to achieve Substantial Completion, and (ii) to complete the Work so that it is ready for final payment as evidenced by Engineer's written recommendation of final payment in accordance with paragraph 14.13.
- 1.25. Contract Item (Pay Item) – A specific unit of work for which a price is provided in the Contract.

- 1.26. Contractor – The person, firm or corporation with whom Owner has entered into the Agreement.
- 1.27. Defective – An adjective which when modifying the word Work refers to Work that is unsatisfactory, faulty or deficient, in that it does not conform to the Contract Documents, or does not meet the requirements of any inspection, reference standard, test or approval referred to in the Contract Documents, or has been damaged prior to Engineer's recommendation of final payment (unless responsibility for the protection thereof has been assumed by Owner at Substantial Completion in accordance with paragraph 14.8 or 14.10).
- 1.28. Drainage System – The system of pipes, ditches, and structures by which surface or subsurface waters are collected and conducted from the airport area.
- 1.29. Drawings – The drawings which show the scope, extent, and character of the Work to be furnished and performed by Contractor and which have been prepared or approved by Engineer and are referred to in the Contract Documents. Shop drawings are not Drawings as so defined.
- 1.30. Effective Date of the Agreement – The date indicated in the Agreement on which it becomes effective, but if no such date is indicated it means the date on which the Agreement is signed and delivered by the last of the two parties to sign and deliver.
- 1.31. Engineer – The person, firm, or corporation named as such in the Agreement.
- 1.32. Engineer's Consultant – A person, firm, or corporation having a contract with Engineer to furnish services as Engineer's independent professional associate or consultant with respect to the Project and who is identified as such in the Supplementary Conditions. The following list of independent professional associates and consultants are considered the Engineer's consultant for this Construction Contract: AVCON, Inc.
- 1.33. Equipment – All machinery, together with the necessary supplies for upkeep and maintenance, and also all tools and apparatus necessary for the proper construction and acceptable completion of the work.
- 1.34. Extra Work – An item of work not provided for in the awarded contract as previously modified by change order or supplemental agreement, but which if found by the Engineer to be necessary to complete the work within the intended scope of the contract as previously modified.
- 1.35. FAA – The Federal Aviation Administration of the U.S. Department of Transportation. When used to designate a person, FAA shall mean the Administrator or his duly authorized representative.
- 1.36. Federal Specifications – The Federal Specifications and Standards, and supplements, amendments, and indices thereto are prepared and issued by the General Services Administration of the Federal Government. They may be obtained from the Specifications Activity, Printed Materials Supply Division, Building 197, Naval Weapons Plant, Washington, D.C. 20407.

- 1.37. Field Order – A written order issued by Engineer which orders minor changes in the Work in accordance with paragraph 9.5 but which does not involve a change in the Contract Price or the Contract Times.
- 1.38. General Requirements – Sections of Division 1 of the Specifications.
- 1.39. Hazardous Waste – The term Hazardous Waste shall have the meaning provided in Section 1004 of the Solid Waste Disposal Act (42 USC Section 6903) as amended from time to time.
- 1.40. Inspector – An authorized representative of the Engineer assigned to make all necessary inspections and/or tests of the work performed or being performed, or of the materials furnished or being furnished by the Contractor.
- 1.41. Intention of Terms – Whenever, in these specifications or on the plans, the words, "directed," "required," "permitted," "ordered," "designated," "prescribed," or words of the like import are used, it shall be understood that the direction, requirement, permission, order, designation, or prescription of the Engineer is intended; and similarly, the words "approved," "acceptable," "Satisfactory," or words of like import, shall mean approved by, or acceptable to, or satisfactory to the Engineer, subject in each case to the final determination of the Owner.
- 1.42. Laboratory – The official testing laboratories of the Owner or such other laboratories as may be designated by the Engineer.
- 1.43. Laws and Regulations; Laws or Regulations – Any and all applicable laws, rules, regulations, ordinances, codes and orders of any and all governmental bodies, agencies, authorities and courts having jurisdiction.
- 1.44. Liens – Liens, charges, security interests, or encumbrances upon real property or personal property.
- 1.45. Lighting – A system of fixtures providing or controlling the light sources used on or near the airport or within the airport buildings. The field lighting includes all luminous signals, markers, floodlights, and illuminating devices used on or near the airport or to aid in the operation of aircraft landing at, taking off from, or taxiing on the airport surface.
- 1.46. Major and Minor Contract Items – A major contract item shall be any item that is listed in the proposal, the total cost of which is equal to or greater than 25 percent of the total amount of the award contract. All other items shall be considered minor contract items.
- 1.47. Materials – Any substance specified for use in the construction of the Contract work.
- 1.48. Mil Specifications – The Military Specifications and Standard, and indices thereto, that are prepared and issued by the Department of Defense.
- 1.49. Milestone – A principal event specified in the Contract Documents relating to an intermediate completion date or time prior to Substantial Completion of all the Work.

- 1.50. Notice of Award – The written notice by Owner to the apparent successful contractor stating that upon compliance by the apparent successful contractor with the conditions precedent enumerated therein, within the time specified, Owner will sign and deliver the Agreement.
- 1.51. Notice to Proceed – A written notice given by Owner to Contractor (with a copy to Engineer) fixing the date on which the Contract Times will commence to run and on which Contractor shall start to perform Contractor's obligations under the Contract Documents.
- 1.52. FDOT – The Florida State Department of Transportation. When used to designate a person, FDOT shall mean the commissioner or his duly authorized representative.
- 1.53. Owner – The public body or authority, corporation, association, firm, or person with whom Contractor has entered into the Agreement and for whom the Work is to be provided.
- 1.54. Partial Utilization – Use by Owner of a substantially completed part of the Work for the purpose for which it is intended (or a related purpose) prior to Substantial Completion of all the Work.
- 1.55. Pavement – The combined surface course, base course, and subbase course, if any, considered as a single unit.
- 1.56. Payment Bond – The approved form of security furnished by the Contractor and his/her surety as a guaranty that he will pay in full all bills and accounts for materials and labor used in the construction of the work.
- 1.57. PCBs – Polychlorinated biphenyls.
- 1.58. Performance Bond – The approved form of security furnished by the Contractor and his/her surety as a guaranty that the Contractor will complete the work in accordance with the terms of the contract.
- 1.59. Petroleum – Petroleum, including crude oil or any fraction thereof which is liquid at standard conditions of temperature and pressure (60 degrees Fahrenheit and 14.7 pounds per square inch absolute), such as oil, petroleum, fuel oil, oil sludge, oil refuse, gasoline, kerosene, and oil mixed with other non-Hazardous Wastes and crude oils.
- 1.60. Plans – The official drawings or exact reproductions which show the location, character, dimensions, and details of the airport and the work to be done and which are to be considered as a part of the contract, supplementary to the specifications.
- 1.61. Project – The total construction of which the Work to be provided under the Contract Documents may be the whole, or a part as indicated elsewhere in the Contract Documents.
- 1.62. Proposal – (See Bid).
- 1.63. Radioactive Material – Source, special nuclear, or byproduct material as defined by the Atomic Energy Act of 1954 (42 USC Section 2011 et seq.) as amended from time to time.

- 1.64. Resident Project Representative - The authorized representative of Engineer who may be assigned to the site or any part thereof.
- 1.65. Runway – The area on the airport prepared for the landing and takeoff of aircraft.
- 1.66. Samples – Physical examples of materials, equipment, or workmanship that are representative of some portion of the Work and which establish the standards by which such portion of the Work will be judged.
- 1.67. Shop Drawings – All drawings, diagrams, illustrations, schedules, and other data or information which are specifically prepared or assembled by or for Contractor and submitted by Contractor to illustrate some portion of the Work.
- 1.68. Special Provisions – The specific clauses setting forth conditions or requirements peculiar to the project under consideration, covering work or materials involved in the proposal and estimate, which are not thoroughly or satisfactorily stipulated in these specifications.
- 1.69. Specifications – Those portions of the Contract Documents consisting of written technical descriptions of materials, equipment, construction systems, standards, and workmanship as applied to the Work and certain administrative details applicable thereto.
- 1.70. Sponsor – For AIP Contracts, the term Sponsor shall have the meaning as the term Owner.
- 1.71. Structures – Airport facilities such as bridges; culverts; catch basins; inlets; retaining walls; cribbing; storm and sanitary sewer lines; water lines; underdrains; electrical ducts, manholes, handholes, lighting fixtures and bases; transformers; flexible and rigid pavements; navigational aids; buildings; vaults; and, other manmade features of the airport that may be encountered in the work and not otherwise classified herein.
- 1.72. Subcontractor – An individual, firm, or corporation having a direct contract with Contractor or with any other Subcontractor for performance of a part of the Work at the site.
- 1.73. Subgrade – The soil which forms the pavement foundation.
- 1.74. Superintendent – The Contractor's executive representative who is present on the work during progress, authorized to receive and fulfill instruction from the Engineer, and who shall supervise and direct the construction.
- 1.75. Substantial Completion – The Work (or a specified part thereof) has progressed to the point where, in the opinion of Engineer as evidenced by Engineer's definitive certificate of Substantial Completion, it is sufficiently complete, in accordance with the Contract Documents, so that the Work (or specified part) can be utilized for the purposes for which it is intended; or if no such certificate is issued, when the Work is complete and ready for final payment as evidenced by Engineer's written recommendation of final payment in accordance with paragraph 14.13. The terms "substantially complete" and "substantially completed" as applied to all or part of the Work refer to Substantial Completion thereof.

- 1.76. Supplemental Agreement – A written agreement between the Contractor and the Owner covering: (1) work that would increase or decrease the total amount of the awarded contract, or any major contract item, by more than 25 percent, such increased or decreased work being within the scope of the originally awarded contract; or (2) work that is not within the scope of the originally awarded contract.
- 1.77. Supplementary Conditions – The part of the Contract Documents which amends or supplements these General Conditions.
- 1.78. Supplier – A manufacturer, fabricator, supplier, distributor, materialman, or vendor having direct contract with Contractor or with any Subcontractor to furnish materials or equipment to be incorporated in the Work by Contractor or any Subcontractor.
- 1.79. Surety – The corporation, partnership, or individual, other than the Contractor, executing payment or performance bonds which are furnished to the Owner by the Contractor.
- 1.80. Taxiway – For the purpose of this document, the term taxiway means the portion of the air operations area of an airport that has been designated by competent airport authority for movement of aircraft to and from the airport's runways or aircraft parking areas.
- 1.81. Underground Facilities – All pipelines, conduits, ducts, cables, wires, manholes, vaults, tanks, tunnels, or other such facilities or attachments, and any encasements containing such facilities which have been installed underground to furnish any of the following services or materials: electricity, gases, steam, liquid petroleum products, telephone, or other communications, cable television, sewage and drainage removal, traffic or other control systems or water.
- 1.82. Unit Price Work – Work to be paid for on the basis of unit prices.
- 1.83. Work – The entire completed construction or the various separately identifiable parts thereof required to be furnished under the Contract Documents. Work includes and is the result of performing or furnishing labor and furnishings and incorporating materials and equipment into the construction, and performing or furnishing services and furnishing documents, all as required by the Contract Documents.
- 1.84. Work Change Directive - A written directive to Contractor, issued on or after the Effective Date of the Agreement and signed by Owner and recommended by Engineer, ordering an addition, deletion, or revision in the Work, or responding to differing or unforeseen physical conditions under which the Work is to be performed as provided in paragraph 4.2 or 4.3 or to emergencies under paragraph 6.18. A Work Change Directive will not change the Contract Price or the Contract Times, but is evidence that the parties expect that the change directed or documented by a Work Change Directive will be incorporated in a subsequently issued Change Order following negotiations by the parties as to its effect, if any, on the Contract Price or Contract Times as provided in Article 10.
- 1.85. Working Day – A working day shall be any day other than a legal holiday, Saturday, or Sunday on which the normal working forces of the Contractor may proceed with regular work for at least 6 hours toward completion of the Contract. Unless work is suspended for causes beyond the Contractor's control, Saturdays, Sundays and holidays on which the Contractor's forces engage

in regular work, requiring the presence of an inspector, will be considered as working days.

- 1.86. Work Period – A work period shall consist of any designated block of time on which the normal working forces of the Contractor may proceed with regular work for at least 5 hours toward completion of the contract. Unless work is suspended for causes beyond the Contractor's control, work occurring on any day, regardless of it being a weekend or holiday, which requires an Inspector, will be considered a work period. Work periods are limited to between 7:00 a.m. and 5:00 p.m. local time Monday through Friday. Weekend work will not be permitted unless contractor obtains written permission from Owner.
- 1.87. Written Amendment – A written amendment of the Contract Documents, signed by Owner and Contractor on or after the Effective Date of the Agreement and normally dealing with the non-engineering or nontechnical rather than strictly construction-related aspects of the Contract Documents.

ARTICLE 2 – PRELIMINARY MATTERS

Delivery of Bonds:

- 2.1. When Contractor delivers the executed Agreements to Owner, Contractor shall also deliver to Owner such Bonds as Contractor may be required to furnish in accordance with paragraph 5.1.

Copies of Documents:

- 2.2. Owner shall furnish to Contractor up to five copies (unless otherwise specified in the Supplementary Conditions) of the Contract Documents as are reasonably necessary for the execution of the Work. Additional copies will be furnished, upon request, at the cost of reproduction.

Commencement of Contract Times; Notice to Proceed:

- 2.3. The Contract Times will commence to run on the thirtieth day after the Effective Date of the Agreement, or, if a Notice to Proceed is given, on the day indicated in the Notice to Proceed. A Notice to Proceed may be given at any time within thirty days after the Effective Date of the Agreement. In no event will the Contract Time commence to run later than the *one hundred twentieth (120th)* day after the day of Bid opening or the *ninetieth (90th)* day after the Effective Date of the Agreement, whichever date is earlier.

Starting the Work:

- 2.4. Contractor shall start to perform the Work on the date when the Contract Times commence to run, but no Work shall be done at the site prior to the date on which the Contract Times commence to run.

Before Starting Construction:

- 2.5. Before undertaking each part of the Work, Contractor shall carefully study and compare the Contract Documents and check and verify pertinent figures shown thereon and all applicable field measurements. Contractor shall promptly report in writing to Engineer any conflict, error, ambiguity or discrepancy which Contractor may discover and shall obtain a written interpretation or clarification from Engineer before proceeding with any Work affected thereby; however, Contractor shall not be liable to Owner or Engineer for failure to report any conflict,

error, ambiguity or discrepancy in the Contract Documents, unless Contractor knew or reasonably should have known thereof.

2.6. Within ten days after the Construction Notice to Proceed contractor shall submit to Engineer for review:

2.6.1. a preliminary progress schedule indicating the times (numbers of days or dates) for starting and completing the various stages of the Work, including any Milestones specified in the Contract Documents;

2.6.2. a preliminary schedule of Shop Drawings and Sample submittals which will list each required submittal and the times for submitting, reviewing and processing such submittal;

2.6.3. a preliminary schedule of values for all of the Work which will include quantities and prices of items aggregating the Contract Price and will subdivide the Work into component parts in sufficient detail to serve as the basis for progress payments during construction. Such prices will include an appropriate amount of overhead and profit applicable to each item of Work.

2.7. Before any Work at the site is started, Contractor and Owner shall each deliver to the other, with copies to each additional insured identified in the Supplementary Conditions, certificates of insurance (and other evidence of insurance which either of them or any additional insured may reasonably request) which Contractor and Owner respectively are required to purchase and maintain in accordance with paragraphs 5.4 and 5.6.

Preconstruction Conference:

2.8. Within twenty (20) days prior to Construction Notice to Proceed, but before any Work at the site is started, a conference attended by Contractor, Engineer and others as appropriate will be held to establish a working understanding among the parties as to the Work and to discuss the schedules referred to in paragraph 2.6, procedures for handling Shop Drawings, and other submittals, processing Applications for Payment and maintaining required records.

Initially Acceptable Schedules:

2.9. Unless otherwise provided in the Contract Documents, at least ten days before submission of the first Application for Payment a conference attended by Contractor, Engineer, and others as appropriate will be held to review for acceptability to Engineer as provided below the schedules submitted in accordance with paragraph 2.6. Contractor shall have an additional ten days to make corrections and adjustments and to complete and resubmit the schedules. No progress payment shall be made to Contractor until the schedules are submitted to and acceptable to Engineer as provided below. The progress schedule will be acceptable to Engineer as providing an orderly progression of the Work to completion within any specified Milestones and the Contract Times, but such acceptance will neither impose on Engineer responsibility for the sequencing, scheduling, or progress of Work nor interfere with or relieve Contractor from Contractor's full responsibility therefore, Contractor's schedule of Shop Drawing and Sample submissions will be acceptable to Engineer as providing a workable arrangement for reviewing and processing the required submittals. Contractor's schedule of values will be acceptable to Engineer as to form and substance.

ARTICLE 3 – CONTRACT DOCUMENTS: INTENT, AMENDING, REUSE

Intent:

3.1. The Contract Documents comprise the entire agreement between Owner and Contractor concerning the Work. The Contract Documents are complementary: what is called for by one is as binding as if called for by all. The Contract Documents will be construed in accordance with the law of the place of the Project.

3.2. It is the intent of the Contract Documents to describe a functionally complete Project (or part thereof) to be constructed in accordance with the Contract Documents. Any Work, materials, or equipment that may reasonably be inferred from the Contract Documents or from prevailing custom or trade usage as being required to produce the intended result will be furnished and performed whether or not specifically called for. When words or phrases, which have a well-known technical or construction industry or trade meaning are used to describe Work, materials, or equipment, such words or phrases shall be interpreted in accordance with the meaning. Clarifications and interpretations of the Contract Documents shall be issued by Engineer as provided in paragraph 9.4.

3.3. Reference to Standards and Specifications of Technical Societies: Reporting and Resolving Discrepancies:

3.3.1. Reference to standards, specifications, manuals or codes of any technical society, organization, or association, or to the Laws or Regulations of any governmental authority, whether such reference be specific or by implication, shall mean the latest standard, specification, manual, code or Laws or Regulations in effect at the time of opening of Bids (or, on the Effective Date of the Agreement if there were no Bids), except as may be otherwise specifically stated in the Contract Documents.

3.3.2. If, during the performance of the Work, Contractor discovers any conflict, error, ambiguity, or discrepancy within the Contract Documents or between the Contract Documents and any provision of any such Law or Regulation applicable to the performance of the Work or of any such standard, specification, manual, or code or of any instruction of any Supplier referred to in paragraph 6.5., Contractor shall report it to Engineer in writing at once, and, Contractor shall not proceed with the Work affected thereby (except in an emergency as authorized by paragraph 6.18) until an amendment or supplement to the Contract Documents has been issued by one of the methods indicated in paragraph 3.5 or 3.6; provide, however, that Contractor shall not be liable to Owner or Engineer for failure to report any such conflict, error, ambiguity or discrepancy unless Contractor knew or reasonably should have known thereof.

3.3.3. Except as otherwise specifically stated in the Contract Documents or as may be provided by amendment or supplement thereto issued by one of the methods indicated in paragraph 3.5 or 3.6, the provisions of the Contract Documents shall take precedence in resolving any conflict, error, ambiguity, or discrepancy between the provisions of the Contract Documents and:

3.3.3.1. the provisions of any such standard, specification, manual, code, or instruction (whether or not specifically incorporated by reference in the Contract Documents): or

3.3.3.2. the provisions of any such Laws or Regulations applicable to the performance of the Work (unless such an interpretation of the provisions of the Contract Documents would result in violation of such Law or Regulation).

No provision of any such standard, specification, manual, code, or instruction shall be effective to change the duties and responsibilities of Owner, Contractor, or Engineer, or any of their subcontractors, consultants, agents, or employees from those set forth in the Contract Documents, nor shall it be effective to assign to Owner, Engineer, or any of Engineer's Consultants, agents, or employees any duty or authority to supervise or direct the furnishing or performance of the Work or any duty or authority to undertake responsibility inconsistent with the provisions of paragraph 9.13 or any other provision of the Contract Documents.

3.3.4. Whenever the plans or specifications are in conflict, resolution of such conflict shall be in the following order of precedence subject to agreement by Engineer:

- Contract Agreement
- Addenda, with those of later date having precedence over those of earlier dates
- Bid Documents
- Supplementary Conditions
- General Conditions
- Construction Drawings
- Technical Specifications
- FAA General Provisions
- Florida DOT Standard Specifications

In case of our inconsistency within the Contract Drawings, the order of procedure is as follows:

- Schedules
- Specific Details
- Typical Details
- Construction Drawings

3.4. Whenever in the Contract Documents the terms "as ordered," "as directed," "as required," "as allowed," "as approved" or terms of like effect or import are used, or the adjectives "reasonable," "suitable," "acceptable," "proper," or "satisfactory" or adjectives of like effect or import are used to describe a requirement, direction, review or judgment of Engineer as to the Work, it is intended that such requirement, direction, review, or judgment will be solely to evaluate, in general, the completed Work for compliance with the requirements of and information in the Contract Documents and conformance with the design concept of the completed Project as a functioning whole as shown or indicated in the Contract Documents (unless there is a specific statement indicating otherwise). The use of any such term or adjective shall not be effective to assign to Engineer any duty or authority to supervise or direct the furnishing or performance of the Work or any duty or authority to undertake responsibility contrary to the provisions of paragraph 9.13 or any other provision of the Contract Documents.

Amending and Supplementing Contract Documents:

3.5. The Contract Documents may be amended to provide for additions, deletions, and revisions in the Work or to modify the terms and conditions thereof in one or more of the following ways:

- 3.5.1. a formal Written Amendment.
- 3.5.2. a Change Order (pursuant to paragraph 10.4) or
- 3.5.3. a Work Change Directive (pursuant to paragraph 10.1).

3.6. In addition, the requirements of the Contract Documents may be supplemented and minor variations, and deviations of the Work may be authorized, in one or more of the following ways:

- 3.6.1. a Field Order (pursuant to paragraph 9.5).
- 3.6.2. Engineer's approval of a Shop Drawing or Sample (pursuant to paragraphs 6.19 and 6.20), or
- 3.6.3. Engineer's written interpretation or clarification (pursuant to paragraph 9.4).

Reuse of Documents:

3.7. Contractor and any Subcontractor or Supplier or other person or organization performing or furnishing any of the Work under a direct or indirect contract with Owner (i) shall not have or acquire any title to or ownership rights in any of the Drawings, Specifications, or other documents (or copies of any thereof) prepared by or bearing the seal of Engineer or Engineer's Consultant, and (ii) shall not reuse any of such Drawings, Specifications, other documents, or copies on extensions of the Project or any other project without written consent of Owner and Engineer and specific written verification or adaption by Engineer.

ARTICLE 4 – AVAILABILITY OF LANDS: SUBSURFACE AND PHYSICAL CONDITIONS; REFERENCE POINTS

4.1 Availability of Lands:

Owner shall furnish, as indicated in the Contract Documents, the lands upon which the Work is to be performed, rights-of-way and easements for access thereto, and such other lands which are designated for the use of Contractor. Upon reasonable written request, Owner shall furnish Contractor with a correct statement of record legal title and legal description of the lands upon which the Work is to be performed and Owner's interest therein as necessary for giving notice of or filing a mechanic's lien against such lands in accordance with applicable Laws and Regulations. Owner shall identify any encumbrances or restrictions not of general application but specifically related to use of lands so furnished with which Contractor will have to comply in performing the Work. Easements for permanent structures or permanent in existing facilities will be obtained and paid for by Owner, unless otherwise provided in the Contract Documents. If Contractor and Owner are unable to agree on entitlement to or the amount or extent of any adjustments in the Contract Price or the Contract Times as a result of any delay in Owner's furnishing these lands, rights-of-way or easements. Contractor may make a claim therefore as provided in Articles 11 and 12. Contractor shall provide for all additional lands and access thereto that may be required for temporary construction facilities or storage of materials and equipment.

4.2. Subsurface and Physical Conditions:

4.2.1. **Reports and Drawings:** Reference is made to the *Information Available to Contractors* for identification of:

4.2.1.1. **Subsurface Conditions:** Those reports of explorations and tests of subsurface conditions at or contiguous to the site that have been utilized by Engineer in preparing the Contract Documents; and

4.2.1.2. **Physical Conditions:** Those drawings of physical conditions in or relating to existing surface or subsurface structures at or contiguous to the site (except Underground Facilities) that have been utilized by Engineer in preparing the Contract Documents.

4.2.2. **Limited Reliance by Contractor Authorized; Technical Data:** Contractor may rely upon the general accuracy of the "technical data" contained in such reports and drawings, but such reports and drawings are not Contract Documents. Such "technical data" is identified in the *Information Available to Contractors*. Except for such reliance on such "technical data," Contractor may not rely upon or make any claim against Owner, Engineer, or any of Engineer's Consultants with respect to:

4.2.2.1. the completeness of such reports and drawings for Contractor's purposes, including, but not limited to, any aspects of the means, methods, techniques, sequences and procedures of construction to be employed by Contractor and safety precautions and programs incident thereto, or

4.2.2.2. other data, interpretations, opinions, and information contained in such reports or shown or indicated in such drawings, or

4.2.2.3. any Contractor interpretation of or conclusion drawn from any "technical data" or any such data, interpretations, opinions, or information.

4.2.3. **Notice of Differing Subsurface or Physical Conditions:** If Contractor believes that any subsurface or physical condition at or contiguous to the site that is uncovered or revealed either:

4.2.3.1. is of such a nature as to establish that any "technical data" on which Contractor is entitled to rely as provided in paragraphs 4.2.1 and 4.2.2 is materially inaccurate, or

4.2.3.2. is of such a nature as to require a change in the Contract Documents, or

4.2.3.3. differs materially from that shown or indicated in the Contract Documents, or

4.2.3.4. is of an unusual nature, and differs materially from conditions ordinarily encountered and generally recognized as inherent in work of the character provided for in the Contract Documents; then Contractor shall, promptly, but in no event later than fifteen (15) days, after becoming aware thereof and before further disturbing conditions affected thereby or performing any Work in connection therewith (except in an emergency as permitted by paragraph 6.18), notify Owner and Engineer in writing about such condition. Contractor shall not further disturb such conditions or perform any Work in connection therewith (except as aforesaid) until receipt of written order to do so.

4.2.4. **Engineer's Review:** Engineer will promptly review the pertinent conditions, determine the necessity of Owner's obtaining additional exploration or tests with respect thereto and advise Owner in writing (with a copy to Contractor) of Engineer's findings and conclusions.

4.2.5. **Possible Contract Documents Change:** If Engineer concludes that a change in the Contract Documents is required as a result of a condition that meets one or more of the categories in paragraph 4.2.3., a Work Change Directive or a Change Order will be issued as provided in Article 10 to reflect and document the consequences of such change.

4.2.6. **Possible Price and Times Adjustments:** An equitable adjustment in the Contract Price or in the Contract Times, or both, will be allowed to the extent that the existence of such uncovered or revealed condition causes an increase or decrease in Contractor's cost of, or time required for performance of the Work; subject, however, to the following:

4.2.6.1. such condition must meet any one or more of the categories described in paragraphs 4.2.3.1 through 4.2.3.4. inclusive;

4.2.6.2. a change in the Contract Documents pursuant to paragraph 4.2.5 will not be an automatic authorization of nor a condition precedent to entitlement to any such adjustment:

4.2.6.3. with respect to Work that is paid for on a Unit Price Basis, any adjustment in Contract price will be subject to the provisions of Article 10 and Paragraph 11.9; and

4.2.6.4. Contractor shall not be entitled to any adjustment in the Contract Price or Times if;

4.2.6.4.1. Contractor knew of the existence of such conditions at the time Contractor made a final commitment to Owner in respect of Contract Price and Contract Times by the submission of a bid or becoming bound under a contract: or

4.2.6.4.2. the existence of such condition could reasonably have been discovered or revealed as a result of any examination, investigation, exploration, test, or study of the site and contiguous areas required by the Project Requirements or Contract Documents to be conducted by or for Contractor prior to Contractor's making such final commitment; or

4.2.6.4.3. Contractor failed to give the written notice within the time and as required by paragraph 4.2.3.

If Owner and Contractor are unable to agree on entitlement to or as to the amount or length of any such equitable adjustment in the Contract Price or Contract Times, a claim may be made therefore as provided in Articles 11 and 12. However, Owner, Engineer, and Engineer's Consultants shall not be liable to Contractor for any claims, costs, losses, or damages sustained by Contractor on or in connection with any other project or anticipated project.

4.3. Physical Conditions – Underground Facilities:

4.3.1. **Shown or Indicated:** The information and data shown or indicated in the Contract Documents with respect to existing Underground Facilities at or contiguous to the site is based on information and

data furnished to Owner or Engineer by the owners of such Underground Facilities or by others. Unless it is otherwise expressly provided in the *Information Available to Contractors*:

4.3.1.1. Owner and Engineer shall not be responsible for the accuracy or completeness of any such information or data; and

4.3.1.2. The cost of all of the following will be included in the Contract Price and Contractor shall have full responsibility for: (i) reviewing and checking all such information and data, (ii) locating all Underground Facilities shown or indicated in the Contract Documents, (iii) coordination of the Work with the owners of such Underground Facilities during construction, and (iv) the safety and protection of all such Underground Facilities as provided in paragraph 6.20 and repairing any damage thereto resulting from the Work.

4.3.2. **Not Shown or Indicated:** If an Underground Facility is uncovered or revealed at or contiguous to the site which was not shown or indicated in the Contract Documents. Contractor shall, promptly after becoming aware thereof and before further disturbing conditions affected thereby or performing any Work in connection therewith (except in an emergency as required by paragraph 6.18), identify the owner of such Underground Facility and give written notice to that owner and to Owner and Engineer. Engineer will promptly review the Underground Facility and determine the extent, if any, to which a change is required in the Contract Documents to reflect and document the consequences of the existence of the Underground Facility. If Engineer concludes that a change in the Contract Documents is required, a Work Change Directive or a Change Order will be issued as provided in Article 10 to reflect and document such consequences. During such time, Contractor shall be responsible for the safety and protection of such Underground Facility as provided in paragraph 6.15. Contractor shall be allowed an increase in the Contract Price or an extension of the Contract Times, or both, to the extent that they are attributable to the existence of any Underground Facility that was not shown or indicated in the Contract Documents and that Contractor did not know of and could not reasonably have been expected to be aware of or to have anticipated. If Owner and Contractor are unable to agree on entitlement to or the amount or length of any such adjustment in Contract Price or Contract Times, Contractor may make a claim, therefore, as provided in Articles 11 and 12. However, Owner, Engineer, and Engineer's Consultants shall not be liable to Contractor for any claims, costs, losses or damages incurred or sustained by Contractor on or in connection with any other project or anticipated project.

Reference Points:

4.4. Owner shall provide engineering surveys to establish reference points for construction which in Engineer's judgment are necessary to enable Contractor to proceed with the Work. Contractor shall be responsible for laying out the Work, shall protect and preserve the established reference points and shall make no changes or relocations without the prior written approval of Owner, Contractor shall report to Engineer whenever any reference point is lost or destroyed or requires relocation because of necessary changes in grades or locations, and shall be responsible for the accurate replacement or relocation of such reference points by professionally qualified personnel.

4.5. Asbestos, PCBs, Petroleum, Hazardous Waste or Radioactive Material:

4.5.1. Owner shall be responsible for any Asbestos, PCBs, Petroleum, Hazardous Waste, or Radioactive Material uncovered or revealed at the site which was not shown or indicated in Drawings or Specifications or identified in the Contract Documents to be within the scope of the Work and which

may present a substantial danger to persons or property exposed thereto in connection with the Work at the site. Owner shall not be responsible for any such materials brought to the site by Contractor, Subcontractor, Suppliers, or anyone else for whom Contractor is responsible.

4.5.2. Contractor shall immediately: (i) stop all Work in connection with such hazardous condition and in any area affected thereby (except in an emergency as required by paragraph 6.18), and (ii) notify Owner and Engineer (and thereafter confirm such notice in writing). Owner shall promptly consult with Engineer concerning the necessity for Owner to retain a qualified expert to evaluate such hazardous condition to take corrective action, if any. Contractor shall not be required to resume Work in connection with such hazardous condition or in any such affected area until after Owner has obtained any required permits related thereto and delivered to Contractor special written notice: (i) specifying that such condition and any affected area is or has been rendered safe for the resumption of Work, or (ii) specifying any special conditions under which such Work may be resumed safely. If Owner and Contractor cannot agree as to entitlement to or the amount or extent of an adjustment, if any, in Contract Price or Contract Times as a result of such Work stoppage or such special conditions under which Work is agreed by Contractor to be resumed, either party may make a claim therefore as provided in Articles 11 and 12.

4.5.3. If after receipt of such special written notice Contractor does not agree to resume such Work based on a reasonable belief it is unsafe, or does not agree to resume such Work under such special conditions, then Owner may order such portion of the Work that is in connection with such hazardous condition or in such affected area to be deleted from the Work. If Owner and Contractor cannot agree as to entitlement to or the amount or extent of an adjustment, if any, in Contract Price or Contract Times as a result of deleting such portion of the Work, then either party may make a claim therefore as provided in Articles 11 and 12. Owner may have such deleted portion of the Work performed by Owner's own forces or others in accordance with Article 7.

4.5.4. To the fullest extent permitted by Laws and Regulations, Owner shall indemnify and hold harmless Contractor, Subcontractors, Engineer, Engineer's Consultants and the officers, directors, employees, agents, other consultants and subcontractors of each and any of them from and against all claims, costs, losses, and damages arising out of or resulting from such hazardous condition, provided that: (i) any such claim, cost, loss, or damage is attributable to bodily injury, sickness, disease, or death, or to injury to or destruction of tangible property (other than the Work itself), including the loss of use resulting therefrom, and (ii) nothing in this subparagraph shall obligate Owner to indemnify any person or entity from and against the consequences of that person's or entity's own negligence.

4.5.5. The provisions of paragraphs 4.2 and 4.3 are not intended to apply to Asbestos, PCBs, Petroleum, Hazardous Waste or Radioactive Material uncovered or revealed at the site.

ARTICLE 5 – BONDS AND INSURANCE

Performance, Payment, and Other Bonds:

5.1. Contractor shall furnish Performance and Payment Bonds, each in an amount at least equal to the Contract Price as security for the faithful performance and payment of all Contractor's obligations under the Contract Documents. These Bonds shall remain in effect at least until one year after the date when final payment becomes due, except as provided otherwise by Laws or Regulations or by the Contract Documents. Contractor shall also furnish such other Bonds as are required by the

Supplementary Conditions. All Bonds shall be in the form prescribed by the Contract Documents except as provided otherwise by Laws or Regulations, and shall be executed by such sureties as are named in the current list of "Companies Holding Certificates of Authority as Acceptable Sureties on Federal Bonds and as Acceptable Reinsuring Companies" as published in Circular 570 (amended) by the Audit Staff, Bureau of Government Financial Operations, U.S. Treasury Department. All Bonds signed by an agent must be accompanied by a certified copy of such agent's authority to act.

5.2. If the surety on any Bond furnished by Contractor is declared a bankrupt or becomes insolvent or its right to do business is terminated in any state where any part of the Project is located or it ceases to meet the requirements of paragraph 5.1. Contractor shall within ten days thereafter substitute another bond and surety, both of which must be acceptable to Owner.

5.3. Licensed Sureties and Insurers; Certificates of Insurance:

5.3.1. All Bonds and insurance required by the Contract Documents to be purchased and maintained by Owner or Contractor shall be obtained from surety or insurance companies that are duly licensed or authorized in the jurisdiction in which the Project is located to issue Bonds or insurance policies for the limits and coverages so required. Such surety and insurance companies shall also meet such additional requirements and qualifications as may be provided in the Supplementary Conditions.

5.3.2. Contractor shall deliver to Owner, with copies to each additional insured identified in the Supplementary Conditions, certificates of insurance (and other evidence of insurance requested by Owner or any other additional insured) which Contractor is required to purchase and maintain in accordance with paragraph 5.4.

Contractor's Liability Insurance:

5.4. Contractor shall purchase and maintain such liability and other insurance as is appropriate for the Work being performed and furnished and as will provide protection from claims set forth below which may arise out of or result from Contractor's performance and furnishing of the Work and Contractor's other obligations under the Contract Documents, whether it is to be performed or furnished by Contractor, any Subcontractor or Supplier, or by anyone directly or indirectly employed by any of them to perform or furnish any of the Work, or by anyone for whose acts any of them may be liable:

5.4.1. claims under workers' compensation, disability benefits and other similar employee benefit acts;

5.4.2. claims for damages because of bodily injury, occupational sickness or disease, or death of Contractor's employees;

5.4.3. claims for damages because of bodily injury, sickness or disease, or death of any person other than Contractor's employees;

5.4.4. claims for damages insured by customary personal injury liability coverage which are sustained: (i) by any person as a result of an offense directly or indirectly related to the employment of such person by Contractor, or by any other person for any other reason;

5.4.5. claims for damages, other than to the Work itself, because of injury to or destruction of tangible property wherever located, including loss of use resulting therefrom; and

5.4.6. claims for damages because of bodily injury or death of any person or property damage arising out of the ownership, maintenance or use of any motor vehicle.

The policies of insurance so required by this paragraph 5.4 to be purchased and maintained shall:

5.4.7. with respect to insurance required by paragraphs 5.4.3 through 5.4.6 inclusive, include as additional insureds (subject to any customary exclusion in respect of professional liability) Owner, Engineer, Engineer's Consultants and any other persons or entities identified in the Supplementary Conditions, all of whom shall be listed as additional insureds, and include coverage for the respective officers and employees of all such additional insureds;

5.4.8. include the specific coverages and be written for not less than the limits of liability provided in the Supplementary Conditions or required by Laws or Regulations, whichever is greater;

5.4.8.1 Contractor's Liability Insurance and the Owner's Protective Liability Insurance specified above shall be provided in not less than the following amount:

a. Injury or death to more than one person or single occurrence	\$1,000,000
b. On and Off Premises Operations Liability	\$1,000,000
c. Explosion and Collapse Hazard	\$1,000,000
d. Underground Hazard	\$1,000,000
e. Completed Operations and Products Liability	\$1,000,000
f. Property damage in account of all occurrences	\$1,000,000
g. Independent Contractors Liability	\$1,000,000
h. Personal Injury Liability Insurance	\$1,000,000

Contractor's Vehicle Insurance as follows:

1. Injury or death to one person	\$1,000,000
2. Injury or death to more than one person or a single occurrence	\$1,000,000
3. Property Damage	\$1,000,000
4. Business Auto Liability, Including all owned, non owned and hired vehicles	\$1,000,000

An Umbrella Policy may be used to meet the above limits.

All policies shall be drawn to cover a period of not less than one (1) year from the date of issue.

5.4.9. include contractual liability insurance covering Contractor's indemnity obligations under paragraphs 6.9, 6.13.1, and 6.22.1 through 6.22.2.8;

5.4.10. contain a provision or endorsement that the coverage afforded will not be cancelled, materially changed or renewal refused until at least thirty days prior written notice has been given to Owner and Contractor and to each other additional insured identified in the Supplementary

Conditions to whom a certificate of insurance has been issued (and the certificates of insurance furnished by the Contractor pursuant to paragraph 5.3.2 will so provide);

5.4.11. remain in effect at least until final payment and at all times thereafter when Contractor may be correcting, removing or replacing defective Work in accordance with paragraph 13.12; and

5.4.12. with respect to completed operations insurance, and any insurance coverage written on an occurrence basis, remain in effect for at least two years after final payment (and Contractor shall furnish Owner and each other additional insured identified in the Supplementary Conditions to whom a certificate of insurance has been issued evidence satisfactory to Owner and any such additional insured of continuation of such insurance at final payment and one year thereafter).

Owner's Liability Insurance:

5.5. In addition to the insurance required to be provided by Contractor under paragraph 5.4, Owner, at Owner's option, may purchase and maintain at Owner's expense Owner's own liability insurance as will protect Owner against claims which may arise from operations under the Contract Documents. Any liability insurance carried by Owner is excess and non-contributory to any and all other coverage whether collectable or not.

Property Insurance:

5.6 Contractor shall purchase and maintain property insurance upon the Work at the site in amount of the full replacement cost thereof (subject to such deductible amounts as may be provided in these Supplementary Conditions or required by Laws and Regulations). This insurance shall:

5.6.1 include the interests of Owner, Contractor, Subcontractors, Engineer, Engineer's Consultants and any other persons or entities identified in the Supplementary Conditions each of whom is deemed to have an insurable interest and shall be listed as an insured or additional insured;

5.6.2 include expenses incurred in the repair or replacement of any insured property (including but not limited to fees and charges of engineers and architects);

5.6.3 cover materials and equipment in transit for incorporation in the Work or stored at the site or at another location that was agreed to in writing by Owner prior to being incorporated in the Work, provided that such materials and equipment have been included in an Application for Payment recommended by Engineer; and

5.6.4 be maintained in effect until final payment is made unless otherwise agreed to in writing by Owner, Contractor, and Engineer with thirty days written notice to each other additional insured to whom a certificate of insurance has been issued.

5.7. NOT USED

5.8. NOT USED

5.9. Owner shall not be responsible for purchasing and maintaining any property insurance to protect the interests of Contractor, Subcontractors or others in the Work to the extent of any deductible

amounts that are identified in the Supplementary Conditions. The risk of loss within such identified deductible amount, will be borne by Contractor, Subcontractor, or others suffering any such loss and if any of them wishes property insurance coverage within the limits of such amounts, each may purchase and maintain it at the purchaser's own expense.

5.10. NOT USED

5.11. NOT USED

Receipt and Application of Insurance Proceeds:

5.12. Any insureds loss under the policies of insurance required by paragraphs 5.5 and 5.6 will be adjusted with Owner and made payable to Owner as fiduciary for the insureds, as their interests may appear, subject to the requirements of any applicable mortgage clause and of paragraph 5.13. Owner shall deposit in a separate account any money so received, and shall distribute it in accordance with such agreement as the parties in interest may reach. If no other special agreement is reached, the damaged Work shall be repaired or replaced, the moneys so received applied on account thereof and the Work and the cost thereof covered by an appropriate Change Order or Written Amendment.

5.13. Owner as fiduciary shall have power to adjust and settle any loss with the insurers unless one of the parties in interest shall object in writing within fifteen days after the occurrence of loss to Owner's exercise of this power. If such objection be made, Owner as fiduciary shall make settlement with the insurers in accordance with such agreement as the parties in interest may reach. If no such agreement among the parties in interest is reached, Owner as fiduciary shall adjust and settle the loss with the insurers and, if required in writing by any party in interest, Owner as fiduciary shall give bond for the proper performance of such duties.

Acceptance of Bonds and Insurance; Option to Replace:

5.14. If either party (Owner or Contractor) has any objection to the coverage afforded by or other provisions of the Bonds or insurance required to be purchased and maintained by the other party in accordance with Article 5 on the basis of non-conformance with the Contract Documents, the objecting party shall so notify the other party in writing within ten days after receipt of the certificates (or other evidence requested) required by paragraph 2.7. Owner and Contractor shall each provide to the other such additional information in respect of insurance provided as the other may reasonably request. If either party does not purchase or maintain all of the Bonds and insurance required of such party by the Contract Documents, such party shall notify the other party in writing of such failure to purchase prior to the start of the Work, or of such failure to maintain prior to any change in the required coverage. Without prejudice to any other right or remedy, the other party may elect to obtain equivalent Bonds or insurance to protect such other party's interests at the expense of the party who was required to provide such coverage, and a Change Order shall be issued to adjust the Contract Price accordingly.

Partial Utilization – Property Insurance:

5.15. If Owner finds it necessary to occupy or use a portion or portions of the Work prior to Substantial Completion of all the Work, such use or occupancy may be accomplished in accordance with paragraph 14.10; provided that no such use or occupancy shall commence before the insurers providing the property insurance have acknowledged notice thereof and in writing effected any changes in

coverage necessitated thereby. The insurers providing the property insurance shall consent by endorsement on the policy or policies, but the property insurance shall not be cancelled or permitted to lapse on account of any such partial use or occupancy.

ARTICLE 6 – CONTRACTOR'S RESPONSIBILITIES

Supervision and Superintendence:

6.1. Contractor shall supervise, inspect and direct the Work competently and efficiently, devoting such attention thereto and applying such skills and expertise as may be necessary to perform the Work in accordance with the Contract Documents. Contractor shall be solely responsible for the means, methods, techniques, sequences and procedures of construction, but Contractor shall not be responsible for the negligence of others in the design or specification of a specific means, method, technique, sequence or procedure of construction which is shown or indicated in and expressly required by the Contract Documents. Contractor shall be responsible to see that the completed Work complies accurately with the Contract Documents.

6.2. Contractor shall keep on the Work at all times during its progress a competent resident superintendent, who shall not be replaced without written notice to Owner and Engineer except under extraordinary circumstances. The superintendent will be Contractor's representative at the site and shall have authority to act on behalf of Contractor. All communications to the superintendent shall be as binding as if given to CONTRACTOR.

Labor, Materials and Equipment:

6.3. Contractor shall provide competent, suitably qualified personnel to survey, lay out and construct the Work as required by the Contract Documents. Contractor shall at all times maintain good discipline and order at the site. Except as otherwise required for the safety or protection of persons or the Work or property at the site or adjacent thereto, and except as otherwise indicated in the Contract Documents, all Work at the site shall be performed during regular working hours and Contractor will not permit overtime work or the performance of Work on Saturday, Sunday or any legal holiday without Owner's written consent given after prior written notice to Engineer.

6.4. Unless otherwise specified in the General Requirements, Contractor shall furnish and assume full responsibility for all materials, equipment, labor, transportation, construction equipment and machinery, tools, appliances, fuel, power, light, heat, telephone, water, sanitary facilities, temporary facilities and all other facilities and incidentals necessary for the furnishing, performance, testing, start-up and completion of the Work.

6.5. All materials and equipment shall be of good quality and new, except as otherwise provided in the Contract Documents. All warranties and guarantees specifically called for by the Specifications shall expressly run to the benefit of Owner. If required by Engineer, Contractor shall furnish satisfactory evidence (including reports of required tests) as to the kind and quality of materials and equipment. All materials and equipment shall be applied, installed, connected, erected, used, cleaned and conditioned in accordance with instructions of the applicable Supplier, except as otherwise provided in the Contract Documents.

Progress Schedule:

6.6. Contractor shall adhere to the progress schedule established in accordance with paragraph 2.9 as it may be adjusted from time to time as provided below:

6.6.1. Contractor shall submit to Engineer for acceptance (to the extent indicated in paragraph 2.9) proposed adjustments in the progress schedule that will not change the Contract Times (or Milestones). Such adjustments will conform generally to the progress schedule then in effect and additionally will comply with any provisions of the General Requirements applicable thereto.

6.6.2. Proposed adjustments in the progress schedule that will change the Contract Times (or Milestones) shall be submitted in accordance with the requirements of paragraph 12.1. Such adjustments may only be made by a Change Order or Written Amendment in accordance with Article 12.

6.7. Substitutes and "Or-Equal" Items:

6.7.1. Whenever an item of material or equipment is specified or described in the Contract Documents by using the name of a proprietary item or the name of a particular Supplier, the specification or description is intended to establish the type, function and quality required. Unless the specification or description contains or is followed by words reading that no like, equivalent or "or-equal" item or no substitution is permitted, other items of material or equipment or material or equipment of other Suppliers may be accepted by Engineer under the following circumstances:

6.7.1.1. "Or-Equal": If in Engineer's sole discretion an item of material or equipment proposed by Contractor is functionally equal to that named and sufficiently similar so that no change in related Work will be required, it may be considered by Engineer as an "or-equal" item, in which case review and approval of the proposed item may, in Engineer's sole discretion, be accomplished without compliance with some or all of the requirements for acceptance of proposed substitute items.

6.7.1.2. Substitute Items: If in Engineer's sole discretion an item of material or equipment proposed by Contractor does not qualify as an "or-equal" item under subparagraph 6.7.2, it will be considered a proposed substitute item. Contractor shall submit sufficient information as provided below to allow Engineer to determine that the item of material or equipment proposed is essentially equivalent to that named and an acceptable substitute therefore. The procedure for review by the Engineer will include the following as supplemented in the General Requirements and as Engineer may decide is appropriate under the circumstances. Requests for review of proposed substitute items of material or equipment will not be accepted by Engineer from anyone other than Contractor. If Contractor wishes to furnish or use a substitute item of material or equipment, Contractor shall first make written application to Engineer for acceptance thereof, certifying that the proposed substitute will perform adequately the functions and achieve the results called for by the general design, be similar in substance to that specified and be suited to the same use as that specified. The application will state the extent, if any, to which the evaluation and acceptance of the proposed substitute will prejudice Contractor's achievement of Substantial Completion on time, whether or not acceptance of the substitute for use in the Work will require a change in any of the Contract Documents (or in the provisions of any other direct contract with Owner for work on the Project) to adapt the design to the proposed substitute and

whether or not incorporation or use of the substitute in connection with the Work is subject to payment of any license fee or royalty. All variations of the proposed substitute from that specified will be identified in the application and available maintenance, repair and replacement service will be indicated. The application will also contain an itemized estimate of all costs or credits that will result directly or indirectly from acceptance of such substitute, including costs of redesign and claims of other contractors affected by the resulting change, all of which will be considered by Engineer in evaluating the proposed substitute. Engineer may require Contractor to furnish additional data about the proposed substitute.

6.7.1.3. Contractor's Expense: All data to be provided by Contractor in support of any proposed "or-equal" or substitute item will be at Contractor's expense.

6.7.2. Substitute Construction Methods or Procedures: If a specific means, method, technique, sequence or procedure of construction is shown or indicated in an expressly required by the Contract Documents, Contractor may furnish or utilize a substitute means, method, technique, sequence or procedure of construction acceptable to Engineer. Contractor shall submit sufficient information to allow Engineer, in Engineer's sole discretion, to determine that the substitute proposed is equivalent to that expressly called for by the Contract Documents. The procedure for review by Engineer will be similar to that provided in subparagraph 6.7.3.

6.7.3. Engineer's Evaluation: Engineer will be allowed a reasonable time within which to evaluate each proposal or submittal made pursuant to paragraphs 6.7.1.1 and 6.7.1.2. Engineer will be the sole judge of acceptability. No "or-equal" or substitute will be ordered, installed or utilized without Engineer's prior written acceptance which will be evidenced by either a Change Order or an approved Shop Drawing. Owner may require Contractor to furnish at Contractor's expense a special performance guarantee or other surety with respect to any "or-equal" or substitute. Engineer will record time required by Engineer and Engineer's Consultants in evaluating substitutes proposed or submitted by Contractor pursuant to paragraphs 6.7.1.1 and 6.7.1.2 and in making changes in the Contract Documents (or in the provisions of any other direct contract with Owner for work on the Project) occasioned thereby. Whether or not Engineer accepts a substitute item so proposed or submitted by Contractor, Contractor shall reimburse Owner for the changes of Engineer and Engineer's Consultants for evaluating each such proposed substitute item.

6.8. Concerning Subcontractors, Suppliers and Others:

The Contractor shall submit a list of Subcontractors and major Material Suppliers for the Owner's approval within (24) hours after Bid Opening. Such list shall be accompanied by an experience statement with pertinent information as to similar projects and other evidence of qualifications from each such Subcontractor, person and organization requested by Owner. If Owner, after due investigation has reasonable objections to any proposed Subcontractor, other person or organization, the Owner may before giving the Notice of Award request the apparent successful Contractor to submit an acceptable Subcontractor without an increase in Bid Price. If the apparent successful Contractor declines to make any such substitution, the Contract shall not be awarded to such Contractor, but his declining to make any such substitution will not constitute grounds for sacrificing his Bid Security. Any Subcontractor, other person or organization so listed and to whom Owner does not make written objection prior to the giving of the Notice of Award will be deemed acceptable to Owner.

6.8.1. Contractor shall not employ any Subcontractor, Supplier or other person or organization (including those acceptable to Owner and Engineer as indicated in paragraph 6.8.2), whether initially or as a substitute, against whom Owner or Engineer may have reasonable objection. Contractor shall not be required to employ any subcontractor, Supplier or other person or organization to furnish or perform any of the Work against whom Contractor has reasonable objection.

6.8.2. If the Supplementary Conditions require the identity of certain Subcontractors, Suppliers or other persons or organizations (including those who are to furnish the principal items of materials or equipment) to be submitted to Owner in advance of the specified date prior to the Effective Date of the Agreement for acceptance by Owner and Engineer, and if Contractor has submitted a list thereof in accordance with the Supplementary Conditions, Owner's or Engineer's acceptance (either in writing or by failing to make written objection thereto by the date indicated for acceptance or objection in the project documents or the Contract Documents) of any such Subcontractor, Supplier or other person or organization so identified may be revoked on the basis of reasonable objection after due investigation, in which case Contractor shall submit an acceptable substitute, the Contract Price will be adjusted by the difference in the cost occasioned by such substitution and an appropriate Change Order will be issued or Written Amendment signed. No acceptance by Owner or Engineer of any such Subcontractor, Supplier or other person or organization shall constitute a waiver of any right of Owner or Engineer to reject defective Work.

6.8.3. Contractor shall be fully responsible to Owner and Engineer for all acts and omissions of the Subcontractors, Suppliers and other persons and organizations performing or furnishing any of the Work under a direct or indirect contract with Contractor just as Contractor is responsible for Contractor's own acts and omissions. Nothing in the Contract Documents shall create for the benefit of any such Subcontractor, Supplier, or other person or organization any contractual relationship between Owner or Engineer and any such Subcontractor, Supplier or other person or organization, nor shall it create any obligation on the part of Owner or Engineer to pay or to see to the payment of any moneys due any such Subcontractor, Supplier or other person or organization except as may otherwise be required by Laws and Regulations.

6.8.4. Contractor shall be solely responsible for scheduling and coordinating the Work of Subcontractors, Suppliers and other persons and organizations performing or furnishing any of the Work under a direct or indirect contract with Contractor. Contractor shall require all Subcontractors, Suppliers and such other persons and organizations performing or furnishing any of the Work to communicate with the Engineer through Contractor.

6.8.5. The divisions and sections of the Specifications and the identifications of any drawings shall not control Contractor in dividing the Work among Subcontractors or Suppliers or delineating the Work to be performed by any specific trade.

6.8.6. All Work performed by Contractor by a Subcontractor or Supplier will be pursuant to an appropriate agreement between Contractor and the Subcontractor or Supplier which specifically binds the Subcontractor or Supplier to the applicable terms and conditions of the Contract Documents for the benefit of Owner and Engineer. Whenever any such agreement is with a Subcontractor or Supplier who is listed as an additional insured on the property insurance provided in paragraph 5.5. or 5.6. the agreement between the Contractor and the Subcontractor or Supplier will contain provisions whereby the Subcontractor or Supplier waives all rights against Owner, Contractor, Engineer, Engineer's Consultants and all other additional insureds for all losses and

damages caused by, arising out of or resulting from any of the perils covered by such policies and any other property insurance applicable to the Work. If the insurers on any such policies require separate waiver forms to be signed by any Subcontractor or Supplier, Contractor will obtain the same.

6.9 Patent Fees and Royalties:

Contractor shall pay all license fees and royalties and assume all costs incident to the use in the performance of the Work or the incorporation in the Work of any invention, design, process, product or device which is the subject of patent rights or copyrights held by others. If a particular invention, design, process, product or device is specified in the Contract Documents for use in the performance of the Work and if to the actual knowledge of Owner or Engineer its use is subject to patent rights or copyrights calling for the payment of any license fee or royalty to others, the existence of such rights shall be disclosed by Owner in the Contract Documents. To the fullest extent permitted by Laws and Regulations, Contractor shall indemnify and hold harmless Owner, Engineer, Engineer's Consultants and the officers, directors, employees, agents and other consultants of each and any of them from and against all claims, costs, losses and damages arising out of or resulting from any infringement of patent rights or copyrights incident to the use in the performance of the Work or resulting from the incorporation in the Work of any invention, design, process, product or device not specified in the Contract Documents.

6.10. Permits:

Unless otherwise provided in the Supplementary Conditions, Contractor shall obtain and pay for all construction permits and licenses. Owner shall assist Contractor, when necessary, in obtaining such permits and licenses. Contractor shall pay all governmental charges and inspection fees necessary for the prosecution of the Work, which are applicable at the time of opening of Bids, or, if there are no Bids, on the Effective Date of the Agreement. Contractor shall pay all charges of utility owners for connections to the Work, and Owner shall pay all charges of such utility owners for capital costs related thereto such as plant investment fees.

6.11. Laws and Regulations:

6.11.1. Contractor shall give all notices and comply with all Laws and Regulations applicable to furnishing and performance of the Work. Except where otherwise expressly required by applicable Laws and Regulations, neither Owner nor Engineer shall be responsible for monitoring Contractor's compliance with any Laws or Regulations.

6.11.2. If Contractor performs any Work knowing or having reason to know that it is contrary to Laws or Regulations, Contractor shall bear all claims, costs, losses and damages caused by, arising out of or resulting therefrom: however, it shall not be Contractor's primary responsibility to make certain that the Specifications and Drawings are in accordance with Laws and Regulations, but this shall not relieve Contractor or Contractor's obligations under paragraph 3.3.2.

6.12. Taxes:

Contractor shall pay all sales, consumer, use and other similar taxes required to be paid by Contractor in accordance with the Laws and Regulations of the place of the Project which are applicable during the performance of the Work.

6.13. Use of Premises:

6.13.1 Contractor shall confine construction equipment, the storage of materials and equipment and the operations of workers to the site and land and areas identified in and permitted by the Contract Documents, rights-of-way, permits and easements, and shall not unreasonably encumber the premises with construction equipment or other materials or equipment. Contractor shall assume full responsibility for any damage to any such land or area, or to the owner or occupant thereof or of any adjacent land or areas, resulting from the performance of the Work. Should any claim be made by any such owner or occupant because of the performance of the Work, Contractor shall promptly settle with such other party by negotiation or otherwise resolve the claim by arbitration or other dispute resolution proceeding or at law. Contractor shall, to the fullest extent permitted by Laws and Regulations, indemnify and hold harmless Owner, Engineer, Engineer's Consultant and anyone directly or indirectly employed by any of them from and against all claims costs, losses and damages arising out of or resulting from any claim or action, legal or equitable, brought by any such owner or occupant against Owner, Engineer or any other party indemnified hereunder to the extent caused by or based upon Contractor's performance of the Work.

6.13.2. During the progress of the Work, Contractor shall keep the premises free from accumulations of waste materials, rubbish and other debris resulting from the Work. At the completion of the Work Contractor shall remove all waste materials, rubbish and debris from and about the premises as well as all tools, appliances, construction equipment and machinery and surplus materials. Contractor shall leave the site clean and ready for occupancy by Owner at Substantial Completion of the Work. Contractor shall restore to original condition all property not designated for alteration by the Contract Documents.

6.13.3. Contractor shall not load nor permit any part of any structure to be loaded in any manner that will endanger the structure, nor shall Contractor subject any part of the Work or adjacent property to stresses or pressures that will endanger it.

6.14. Record Documents:

Contractor shall maintain in a safe place at the site one record copy of all Drawings, Specifications, Addenda, Written Amendments, Change Orders, Work Change Directives, Field Orders and written interpretations and clarifications (issued pursuant to paragraph 9.4) in good order and annotated to show all changes made during construction. These record documents together with all approved Samples and a counterpart of all approved Shop Drawings will be available to Engineer for reference. Upon completion of the Work, these record documents, Samples and Shop Drawings will be delivered to Engineer for Owner.

6.15. Safety and Protection:

Contractor shall be responsible for initiating, maintaining and supervising all safety precautions and programs in connection with the Work. Contractor shall take all necessary precautions for the safety of, and shall provide the necessary protection to prevent damage, injury or loss to:

6.15.1. all persons on the Work site or who may be affected by the Work;

- 6.15.2. all the Work and materials and equipment to be incorporated therein, whether in storage on or off the site; and
- 6.15.3. other property at the site or adjacent thereto, including trees, shrubs, lawns, walks, pavements, roadways, structures, utilities and Underground Facilities not designated for removal, relocation or replacement in the course of construction.

Contractor shall comply with all applicable Laws and Regulations of any public body having jurisdiction for safety of persons or property or to protect them from damage, injury or loss; and shall erect and maintain all necessary safeguards for such safety and protection. Contractor shall notify owners of adjacent property and of Underground Facilities and utility owners when prosecution of the Work may affect them, and shall cooperate with them in the protection, removal, relocation and replacement of their property. All damage, injury or loss to any property referred to in paragraph 6.15.2. or 6.15.3. caused, directly or indirectly, in whole or in part, by Contractor, any Subcontractor, Supplier or any other person or organization directly or indirectly employed by any of them to perform or furnish any of the Work or anyone for whose acts any of them may be liable, shall be remedied by Contractor (except damage or loss attributable to the fault of Drawings or Specifications or to the acts or omissions of Owner or Engineer or Engineer's Consultant or anyone employed by any of them or anyone for whose acts any of them may be liable, and not attributable, directly or indirectly, in whole or in part, to the fault or negligence of Contractor or any Subcontractor, Supplier or other person or organization directly or indirectly employed by any of them). Contractor's duties and responsibilities for safety and for protection of the Work shall continue until such time as all the Work is completed and Engineer has issued a notice to Owner and Contractor in accordance with paragraph 14.13. that the Work is acceptable (except as otherwise expressly provided in connection with Substantial Completion).

6.16. Safety Representative:

Contractor shall designate a qualified and experienced safety representative at the site whose duties and responsibilities shall be the prevention of accidents and the maintaining and supervising of safety precautions and programs.

6.17. Hazard Communication Programs:

Contractor shall be responsible for coordinating any exchange of material safety data sheets or other hazard communication information required to be made available to or exchanged between or among employers at the site in accordance with Laws or Regulations.

6.18. Emergencies:

In emergencies affecting the safety or protection of persons or the Work or property at the site or adjacent thereto, Contractor, without special instruction or authorization from Owner or Engineer, is obligated to act to prevent threatened damage, injury or loss. Contractor shall give Engineer prompt written notice if Contractor believes that any significant changes in the Work or variations from the Contract Documents have been caused thereby. If Engineer determines that a change in the Contract Documents is required because of the action taken by Contractor in response to such an emergency, a Work Change Directive or Change Order will be issued to document the consequences of such action.

6.19. Shop Drawings and Samples:

6.19.1. Contractor shall submit Shop Drawings to Engineer for review and approval in accordance with the accepted schedule of Shop Drawings and Sample submittals (see paragraph 2.9.). All submittals will be identified as Engineer may require and in the number of copies specified in the General Requirements. The data shown on the Shop Drawings will be complete with respect to quantities, dimensions, specified performance and design criteria, materials and similar data to shown Engineer the materials and equipment Contractor proposes to provide and to enable Engineer to review the information for the limited purposes required by paragraph 6.26.

6.19.2. Contractor shall also submit Samples to Engineer for review and approval in accordance with said accepted schedule of Shop Drawings and Sample submittals. Each Sample will be identified clearly as to material, Supplier, pertinent data such as catalog numbers and the use for which intended and otherwise as Engineer may require to enable Engineer to review the submittal for the limited purposes required by paragraph 6.20. The numbers of each Sample to be submitted will be as specified in the Specifications.

6.20. Submittal Procedures:

6.20.1. Before submitting each Shop Drawing or Sample, Contractor shall have determined and verified:

6.20.1.1 all field measurements, quantities, dimensions, specified performance criteria, installation requirements, materials, catalog numbers and similar information with respect thereto,

6.20.1.2. all materials with respect to intended use, fabrication, shipping, handling storage, assembly and installation pertaining to the performance of the Work, and

6.20.1.3. all information relative to Contractor's sole responsibilities in respect of means, methods, techniques, sequences and procedures of construction and safety precautions and programs incident thereto.

Contractor shall also have reviewed and coordinated each Shop Drawing or Sample with other Shop Drawings and Samples and with the requirements of the Work and the Contract Documents.

6.20.2 Each submittal will bear a stamp or specific written indication that Contractor has satisfied Contractor's obligations under the Contract Documents with respect to Contractor's review and approval of that submittal.

6.20.3. At the time of each submission, Contractor shall give Engineer specific written notice of such variations, if any, that the Shop Drawing or Sample submitted may have from the requirements of the Contract Documents, such notice to be in a written communication separate from the submittal; and, in addition, shall cause a specific notation to be made on each Shop Drawing and Sample submitted to Engineer for review and approval of each such variation.

6.20.4. Engineer will review and approve Shop Drawings and Samples in accordance with the schedule of Shop Drawings and Sample submittals accepted by Engineer as required by paragraph 2.9. Engineer's review and approval will be only to determine if the items covered by the submittals will, after installation or incorporation in the Work, conform to the information given in the Contract Documents and be compatible with the design concept of the completed Project as a functioning whole as indicated

by the Contract Documents. Engineer's review and approval will not extend to means, methods, techniques, sequences or procedures of construction (except where a particular means, method, technique, sequence or procedure of construction is specifically and expressly called for by the Contract Documents) or to safety precautions or programs incident thereto. The review and approval of a separate item as such will not indicate approval of the assembly in which the item functions. Contractor shall make corrections required by Engineer, and shall return the required number of corrected copies of Shop Drawings and submit as required new Samples for review and approval. Contractor shall direct specific attention in writing to revisions other than the corrections called for by Engineer on previous submittals.

6.20.5. Engineer's review and approval of Shop Drawings or Samples shall not relieve Contractor from responsibility for any variation from the requirements of the Contract Documents unless Contractor has in writing called Engineer's attention to each such variation at the time of submission as required by paragraph 6.20.3 and Engineer has given written approval of each such variation by specific written notation thereof incorporated in or accompanying Shop Drawing or Sample approval; nor will any approval by Engineer relieve Contractor from responsibility for complying with the requirements of paragraph 6.20.

6.20.6. Where a Shop Drawing or Sample is required by the Contract Documents or the schedule of Shop Drawings and Sample submissions accepted by Engineer as required by paragraph 2.9, any related Work performed prior to Engineer's review and approval of the pertinent submittal will be at the sole expense and responsibility of Contractor.

6.21. Continuing the Work:

Contractor shall carry on the Work and adhere to the progress schedule during all disputes or disagreements with Owner. No Work shall be delayed or postponed pending resolution of any disputes or disagreements, except as permitted by paragraph 15.5 or as Owner and Contractor may otherwise agree in writing.

6.22. Contractor's General Warranty and Guarantee:

6.22.1. Contractor warrants and guarantees to Owner, Engineer and Engineer's Consultants that all Work will be in accordance with the Contract Documents and will not be defective. Contractor's warranty and guarantee hereunder excludes defects or damage caused by:

6.22.1.1. abuse, modification or improper maintenance or operation by persons other than Contractor, Subcontractors or Suppliers; or

6.22.1.2. normal wear and tear under normal usage.

6.22.2. Contractor's obligation to perform and complete the Work in accordance with the Contract Documents shall be absolute. None of the following will constitute an acceptance of Work that is not in accordance with the Contract Documents or a release of Contractor's obligation to perform the Work in accordance with the Contract Documents:

6.22.2.1. observations by Engineer;

- 6.22.2.2. recommendation of any progress or final payment by Engineer;
- 6.22.2.3. the issuance of a certificate of Substantial Completion or any payment by Owner to Contractor under the Contract Documents;
- 6.22.2.4. use or occupancy of the Work or any part thereof by Owner;
- 6.22.2.5. any acceptance by Owner or any failure to do so;
- 6.22.2.6. any review and approval of Shop Drawing or Sample submittal or the issuance of a notice of acceptability by Engineer pursuant to paragraph 14.13;
- 6.22.2.7. any inspection, test or approval by others; or
- 6.22.2.8. any correction of defective Work by Owner.

6.23 Indemnification:

6.23.1. To the fullest extent permitted by Laws and Regulations. Contractor shall indemnify and hold harmless Owner, Engineer, Engineer's Consultants and the officers, directors, employees, agents and other consultants of each and any of them from and against all claims, costs, losses and damages (including but not limited to all fees and charges of engineers, architects, attorneys and other professionals and all court or arbitration or other dispute resolution costs) caused by, arising out of or resulting from the performance of the Work, provided that any such claim, cost, loss or damage: (i) is attributable to bodily injury, sickness, disease or death, or to injury to or destruction of tangible property (other than the Work itself), including the loss of use resulting therefrom, and (ii) is caused in whole or in part by any negligent act or omission of Contractor, any Subcontractor, any Supplier, any person or organization directly or indirectly employed by any of them to perform or furnish any of the Work or anyone for whose acts any of them may be liable, regardless of whether or not caused in part by any negligence or omission of a person or entity indemnified hereunder or whether liability is imposed upon such indemnified party by Laws and Regulations regardless of the negligence of any such person or entity.

6.23.2. In any and all claims against Owner or Engineer or any of their respective consultants, agents, officers, directors or employees by any employee (or the survivor or personal representative of such employee) of Contractor, any Subcontractor, any Supplier, any person or organization directly or indirectly employed by any of them to perform or furnish any of the Work, or anyone for whose acts any of them may be liable, the indemnification obligation under paragraph 6.23.1 shall not be limited in any way by any limitation on the amount or type of damages, compensation or benefits payable by or for Contractor or any such Subcontractor, Supplier or other person or organization under workers' compensation acts, disability benefit acts or other employee benefit acts.

6.23.3. The indemnification obligations of Contractor under paragraph 6.23.1 shall not extend to the liability of Engineer and Engineer's Consultants, officers, directors, employees or agents caused by the professional negligence, errors or omissions of any of them.

6.24. Survival of Obligations:

All representations, indemnifications, warranties and guarantees made in, required by or given in accordance with the Contract Documents, as well as all continuing obligations indicated in the Contract Documents, will survive final payment, completion and acceptance of the Work and termination or completion of the Agreement.

ARTICLE 7 – OTHER WORK

Related Work at Site:

7.1. Owner may perform other work related to the Project at the site by Owner's own forces, or let other direct contracts therefore which shall contain General Conditions similar to these, or have other work performed by utility owners. If the fact that such other work is to be performed was not noted in the Contract Documents, then; (i) written notice thereof will be given to Contractor prior to starting any such other work, and (ii) Contractor may make a claim therefore as provided in Articles 11 and 12 if Contractor believes that such performance will involve additional expense to Contractor or requires additional time and the parties are unable to agree as to the amount or extent thereof.

7.2. Contractor shall afford each other contractor who is a party to such a direct contract and each utility owner (and Owner if Owner is performing the additional work with Owner's employees) proper and safe access to the site and a reasonable opportunity for the introduction and storage of materials and equipment and the execution of such other work and shall properly connect and coordinate the Work with theirs. Unless otherwise provided in the Contract Documents. Contractor shall do all cutting, fitting, and patching of the Work that may be required to make its several parts come together properly and integrate with such other work. Contractor shall not endanger any work of others by cutting, excavating or otherwise altering their work and will only cut or alter their work with the written consent of Engineer and the others whose work will be affected. The duties and responsibilities of Contractor under this paragraph are for the benefit of such utility owners and other contractors to the extent that there are comparable provisions for the benefit of Contractor in said direct contracts between Owner and such utility owners and other contractors.

7.3. If the proper execution or results of any part of Contractor's Work depends upon work performed by others under this Article 7. Contractor shall inspect such other work and promptly report to Engineer in writing any delays, defects or deficiencies in such other work that render it unavailable or unsuitable for the proper execution and results of Contractor's Work. Contractor's failure so to report will constitute an acceptance of such other work as fit and proper for integration with Contractor's Work except for latent or non-apparent defects and deficiencies in such other work.

Coordination:

7.4. If Owner contracts with others for the performance of other work on the Project at the site, the following will be set forth in Supplementary Conditions:

7.4.1. the person, firm or corporation who will have authority and responsibility for coordination of the activities among the various prime contractors will be identified;

7.4.2. the specific matters to be covered by such authority and responsibility will be itemized: and

7.4.3. the extent of such authority and responsibilities will be provided.

Unless otherwise provided in the Supplementary Conditions, Owner shall have sole authority and responsibility in respect of such coordination.

ARTICLE 8 – OWNER'S RESPONSIBILITIES

- 8.1.** Except as otherwise provided in these General Conditions, Owner shall issue all communications to Contractor through Engineer.
- 8.2.** In case of termination of the employment of Engineer, Owner shall appoint an engineer, whose status under the Contract Documents shall be that of the former Engineer.
- 8.3.** Owner shall furnish the data required of Owner under the Contract Documents promptly and shall make payments to Contractor promptly when they are due as provided in paragraphs 14.4 and 14.13.
- 8.4.** Owner's duties in respect of providing lands and easements and providing engineering surveys to establish reference points are set forth in paragraphs 4.1 and 4.4. Paragraph 4.2 refers to Owner's identifying and making available to Contractor copies of reports of explorations and tests of subsurface conditions at the site and drawings of physical conditions in existing structures at or contiguous to the site that have been utilized by Engineer in preparing the Contract Documents.
- 8.5.** Owner's responsibilities in respect of purchasing and maintaining liability and property insurance are set forth in paragraphs 5.5 through 5.6.
- 8.6.** Owner is obligated to execute Change Orders as indicated in paragraph 10.4.
- 8.7.** Owner's responsibility in respect of certain inspections, tests and approvals is set forth in paragraph 13.4.
- 8.8.** In connection with Owner's right to stop Work or suspend Work, see paragraphs 13.10 and 15.1. Paragraph 15.2 deals with Owner's right to terminate services of Contractor under certain circumstances.
- 8.9.** The Owner shall not supervise, direct or have control or authority over, nor be responsible for, Contractor's means, methods, techniques, sequences or procedures of construction or the safety precautions and programs incident thereto, or for any failure of Contractor to comply with Laws and Regulations applicable to the furnishing or performance of the Work. Owner will not be responsible for Contractor's failure to perform or furnish the Work in accordance with the Contract Documents.
- 8.10.** Owner's responsibility in respect of undisclosed Asbestos, PCBs, Petroleum, Hazardous Waste or Radioactive Materials uncovered or revealed at the site is set forth in paragraph 4.5.

8.11. If and to the extent Owner has agreed to furnish Contractor reasonable evidence that financial arrangements have been made to satisfy Owner's obligations under the Contract Documents, Owner's responsibility in respect thereof will be as set forth in the Supplementary Conditions.

ARTICLE 9 – ENGINEER'S STATUS DURING CONSTRUCTION

Owner's Representative:

9.1. Engineer will be Owner's representative during the construction period. The duties and responsibilities and the limitations of authority of Engineer as Owner's representative during construction are set forth in the Contract Documents and shall not be extended without written consent of Owner and Engineer.

Visits to Site:

9.2. Engineer will make visits to the site at intervals appropriate to the various stages of construction as Engineer deems necessary in order to observe as an experienced and qualified design professional the progress that has been made and the quality of the various aspects of Contractor's executed Work. Based on information obtained during such visits and observations, Engineer will endeavor for the benefit of Owner to determine, in general, if the Work is proceeding in accordance with the Contract Documents. Engineer will not be required to make exhaustive or continuous on-site inspections to check the quality or quantity of the Work. Engineer's efforts will be directed toward providing for Owner a greater degree of confidence that the completed Work will conform generally to the Contract Documents. On the basis of such visits and on-site observations, Engineer will keep Owner informed of the progress of the Work and will endeavor to guard Owner against defective Work. Engineer's visits and on-site observations are subject to all the limitations on Engineer's authority and responsibility set forth in paragraph 9.13, and particularly, but without limitation, during or as a result of Engineer's on-site visits or observations of Contractor's Work Engineer will not supervise, direct, control or have authority over or be responsible for Contractor's means, methods, techniques, sequences or procedures of construction, or the safety precautions and programs incident thereto, or for any failure of Contractor to comply with Laws and Regulations applicable to the furnishing or performance of the Work.

Project Representative:

9.3. If Owner and Engineer agree, Engineer will furnish a Resident Project Representative to assist Engineer in providing more continuous observation of the Work. The responsibilities and authority and limitations thereon of any such Resident Project Representative and assistants will be as provided in paragraph 9.13 and in the Supplementary Conditions. If Owner designates another representative or agent to represent Owner at the site who is not Engineer's Consultant, agent or employee, the responsibilities and authority and limitations thereon of such other person will be as provided in the Supplementary Conditions.

9.3.1 Engineer may furnish a Resident Project Representative, assistants and other field staff as needed, to assist Owner in observing performance of the Work. The Resident Project Representative is to observe and inspect, in the Owner's interest, the materials furnished and the work done as the work progresses in order to insure full and complete compliance with the contract and to verify quantities of work completed.

9.3.2 Owner may also designate one of its employees to represent Owner for these purposes.

9.3.3 Engineer, Resident Project Representative, Owner and all such other persons referred to shall have unrestricted access to all parts of the Work. Contractor shall cooperate by supplying necessary facilities and assistance required by above persons to carry out their work of observation and inspection.

9.3.4 It is not the function of the Engineer, Resident Project Representative or Owner to supervise or direct the manner in which the work to be done under this Contract is carried on or conducted. The Engineer, Resident Project Representative or Owner is not responsible for construction means, methods, techniques, sequences or procedures, or for safety precautions and programs in connection with the work, and they will not be responsible for the Contractor's failure to carry out the work in accordance with the Contract Documents. Nevertheless, Contractor agrees that any method or procedure, which in the opinion of the Engineer or Owner does not achieve the required results or quality of the work specified, shall be discontinued immediately upon the order of the Engineer.

9.3.5 All communications between Contractor and Engineer or Contractor and Owner are to be through the Resident Project Representative.

9.3.6 Duties and Responsibilities of Resident Project Representative (RPR):

- 1) RPR will act as directed by and under the supervision of Engineer and/or Owner, and will confer with Engineer and Owner regarding RPR's actions. RPR's dealings in matters pertaining to the on-site work shall in general be with Engineer and Contractor keeping Owner advised as necessary. RPR's dealings with subcontractors shall only be through or with the full knowledge and approval of Contractor.
- 2) Review progress schedule, schedule of Shop Drawing submittals and schedule of values prepared by Contractor and consult with Engineer and Owner concerning acceptability.
- 3) Attend meetings with Contractor, such as pre-construction conferences, progress meetings, job conferences and other project-related meetings, and prepare and circulate copies of minutes thereof.
- 4) Serve as Engineer's and Owner's liaison with Contractor, working principally through Contractor's superintendent and assist in understanding the intent of the Contract Documents.
- 5) Advise Engineer, Owner and Contractor of the commencement of any Work requiring a Shop Drawing or sample if the submittal has not been approved by Engineer.
- 6) Conduct on-site observations of the Work in progress to assist Engineer and Owner in determining if the Work is in general proceeding in accordance with the Contract Documents. Report to Engineer and Owner whenever RPR believes that any Work is unsatisfactory, faulty or defective or does not conform to the Contract Documents, or has been damaged, or does not meet the requirements of any inspection, test or approval required to be made; and advise Engineer and Owner of Work that RPR believes should be

- corrected or rejected or should be uncovered for observation, or requires special testing, inspection or approval.
- 7) Report to Engineer and Owner when clarifications and interpretations of the Contract Documents are needed and transmit to Contractor clarifications and interpretations as issued by Engineer.
 - 8) Consider and evaluate Contractor's suggestions for modifications in Drawings or Specifications and report with RPR's recommendations to Engineer and Owner. Transmit to Contractor decisions as issued by Engineer and/or Owner.
 - 9) Maintain orderly files for correspondence, reports of job conferences, Shop Drawings and samples, reproductions of original Contract Documents including all Work Directive Changes, Addenda, Change Orders, Field Orders, additional Drawings issued subsequent to the execution of the Contract, Engineer's clarifications and interpretations of the Contract Documents, progress reports, and other Project related documents.
 - 10) Keep a diary or log book, recording Contractor hours on the job site, weather conditions, data relative to questions of Work Directive Changes, Change Orders or Changed conditions, list of job site visitors, daily activities, decisions, observations in general, and specific observations in more detail as in the case of observing test procedures; and send copies to Engineer and Owner.
 - 11) Record names, addresses and telephone numbers of all Contractors, subcontractors and major suppliers of materials and equipment.
 - 12) Furnish Engineer and Owner periodic reports as required of progress of the Work and of Contractor's compliance with the progress schedule and schedule of Shop Drawing and sample submittals.
 - 13) Draft proposed Change Orders and Work Directive Changes, obtaining backup material from Contractor and recommend to Engineer and Owner Change Orders, Work Directive Changes, and Field Orders.
 - 14) Report immediately to Engineer and Owner upon the occurrence of any accident.
 - 15) Review applications for payment with Contractor for compliance with the established procedure for their submission and forward with recommendations to Engineer, noting particularly the relationship of the payment requested to the schedule of values, Work completed and materials and equipment delivered at the site but not incorporated in the Work.
 - 16) During the course of the Work, verify that certificates, maintenance and operation manuals and other data required to be assembled and furnished by Contractor are applicable to the items actually installed and in accordance with the Contract Documents, and have this material delivered to Engineer for review and forwarding to Owner prior to final payment for the work.

- 17) Before Engineer issues a Certificate of Substantial Completion, submit to Contractor a list of observed items requiring completion or correction.
- 18) Conduct final inspection in the company of Engineer, Owner and Contractor and prepare a final list of items to be completed or corrected.
- 19) Observe that all items on final list have been completed or corrected and make recommendations to Engineer and Owner concerning acceptance.

9.3.7 Limitations of Authority of Resident Project Representative (RPR):

- 1) Shall not authorize any deviation from the Contract Documents or substitution of materials or equipment, unless authorized by Engineer or Owner.
- 2) Shall not exceed limitations of Engineer's authority as set forth in the Contract Documents.
- 3) Shall not undertake any of the responsibilities of Contractor, subcontractors or Contractor's superintendent.
- 4) Shall not advise on, issue directions relative to or assume control over any aspect of the means, methods, techniques, sequences or procedures of construction unless such advice or directions are specifically required by the Contract Documents.
- 5) Shall not advise on, issue directions regarding or assume control over safety precautions and programs in connection with the Work.
- 6) Shall not accept Shop Drawing or sample submittals from anyone other than Contractor.

9.3.8 The Engineer and or Owner shall have the authority to reject any work, or materials, or any part thereof, which does not in his opinion conform to the plans, drawings, specifications and contract, and it shall be permissible for him to do so at any time during the progress of the work and until its acceptance.

No material of any kind shall be used upon the work until it has been inspected and accepted by the Engineer. All materials rejected shall be removed immediately from the work and not again offered for inspection. Any materials or workmanship found at any time to be defective or not of the quality or character required by the plans and specifications shall be remedied at once regardless of previous inspection.

Such inspection shall not relieve the Contractor from any obligation to perform said work strictly in accordance with the plans and specifications and work not so constructed shall be removed and made good by the Contractor at his own expense, and free from all expense to the Owner whenever so ordered by the Owner without reference to any previous oversight or error in inspection.

9.4. Clarifications and Interpretations:

Engineer will issue with reasonable promptness such written clarifications or interpretations of the requirements of the Contract Documents (in the form of Drawings or otherwise) as Engineer may determine necessary, which shall be consistent with the intent of and reasonably inferable from Contract Documents. Such written clarifications and interpretations will be binding on Owner and Contractor. If Owner or Contractor believes that a written clarification or interpretation justifies an adjustment in the Contract Price or the Contract Times and the parties are unable to agree to the amount or extent thereof, if any, Owner or Contractor may make a written claim therefore as provided in Article 11 or Article 12.

9.5. Authorized Variations in Work:

Engineer may authorize minor variations in the Work from the requirements of the Contract Documents which do not involve an adjustment in the Contract Price or the Contract Times and are compatible with the design concept of the completed Project as a functioning whole as indicated by the Contract Documents. These may be accomplished by a Field Order and will be binding on Owner and also on Contractor who shall perform the Work involved promptly. If Owner or Contractor believes that a Field Order justifies an adjustment in the Contract Price or the Contract Times and the parties are unable to agree as to the amount or extent thereof, Owner or Contractor may make a written claim therefore as provided in Article 11 or 12.

9.6. Rejecting Defective Work:

Engineer will have authority to disapprove or reject Work which Engineer believes to be defective, or that Engineer believes will not produce a complete Project that conforms to the Contract Documents or that will prejudice the integrity of the design concept of the completed Project as a functioning whole as indicated by the Contract Documents. Engineer will also have authority to require special inspection or testing of the Work as provided in paragraph 13.9, whether or not the Work is fabricated, installed or completed.

9.7. Shop Drawings, Change Orders and Payments:

9.7.1 In connection with Engineer's authority as to Shop Drawings and Samples, see paragraphs 6.19 through 6.20.4 inclusive.

9.7.2. In connection with Engineer's authority as to Change Orders, see Articles 10, 11, and 12.

9.7.3. In connection with Engineer's authority as to Applications for Payment, see Article 14.

9.8. Determinations for Unit Prices:

Engineer will determine the actual quantities and classifications of Unit Price Work performed by Contractor. Engineer will review with Contractor the Engineer's preliminary determinations on such matters before rendering a written decision thereon (by recommendation of an Application for Payment or otherwise). Engineer's written decision thereon will be final and binding upon Owner and Contractor, unless, within ten days after the date of any such decision, either Owner or Contractor delivers to the other and to Engineer written notice of intention to appeal from Engineer's decision and, a formal proceeding is instituted by the appealing party in a forum of competent jurisdiction to exercise such rights or remedies as the appealing party may have with respect to Engineer's decision, unless otherwise

agreed in writing by Owner and Contractor. Such appeal will not be subject to procedures of paragraph 9.9.

9.9. Decisions on Disputes:

9.9.1. Engineer will be the initial interpreter of the requirements of the Contract Documents and judge of the acceptability of the Work there under. Claims, disputes and other matters relating to the acceptability of the Work or the interpretation of the requirements of the Contract Documents pertaining to the performance and furnishing of the Work and Claims under Articles 11 and 12 in respect of changes in the Contract Price or Contract Times will be referred initially to Engineer in writing with a request for a formal decision in accordance with this paragraph. Written notice of each such claim, dispute or other matter will be delivered by the claimant to Engineer and the other party to the Agreement promptly, but in no event later than fifteen (15) days, after the start of the occurrence or event giving rise thereto, and written supporting data will be submitted to Engineer and the other party within forty-five (45) days after the start of such occurrence or event unless Engineer allows an additional period of time for the submission of additional or more accurate data in support of such claim, dispute or other matter. The opposing party shall submit any response to Engineer and the claimant within thirty days after receipt of the claimant's last submittal (unless Engineer allows additional time). Engineer will render a formal decision in writing within thirty days after receipt of the opposing party's submittal, if any, in accordance with this paragraph. Engineer's written decision on such claim, dispute or other matter will be final and binding upon Owner and Contractor unless: a written notice of intention to appeal from Engineer's written decision is delivered by Owner or Contractor to the other and to Engineer within thirty days after the date of such decision and a formal proceeding is instituted by the appealing party in a forum of competent jurisdiction to exercise such rights or remedies as the appealing party may have with respect to such claim, dispute or other matter in accordance with applicable Laws and Regulations within sixty days of the date of such decision, unless otherwise agreed in writing by Owner and Contractor.

9.9.2. When functioning as interpreter and judge under paragraph 9.9.1, Engineer will not show partiality to Owner or Contractor and will not be liable in connection with any interpretation or decision rendered in good faith in such capacity. The rendering of a decision by Engineer pursuant to paragraphs 9.8 or 9.9 with respect to any such claim, dispute or other matter (except any which have been waived by the making or acceptance of final payment as provided in paragraph 14.15) will be a condition precedent to any exercise by Owner or Contractor of such rights or remedies as either may otherwise have under the Contract Documents or by Laws or Regulations in respect of any such claim, dispute or other matter.

9.10. Not Used

9.11. Not Used

9.12. Not Used

9.13. Limitations on Engineer's Authority and Responsibilities:

9.13.1. Neither Engineer's authority or responsibility under this Article 9 or under any other provision of the Contract Documents nor any decision made by Engineer in good faith either to exercise or not exercise such authority or responsibility or the undertaking, exercise or performance

of any authority or responsibility by Engineer shall create, impose or give rise to any duty owed by Engineer to Contractor, any Subcontractor, and Supplier, any other person or organization, or to any surety for employee or agent of any of them.

9.13.2. Engineer will not supervise, direct, control or have authority over or be responsible for Contractor's means, methods, techniques, sequences or procedures of construction, or the safety precautions and programs incident thereto, or for any failure of Contractor to comply with Laws and Regulations applicable to the furnishing or performance of the Work. Engineer will not be responsible for Contractor's failure to perform or furnish the Work in accordance with the Contract Documents.

9.13.3. Engineer will not be responsible for the acts or omissions of Contractor or of any Subcontractor, any Supplier, or of any other person or organization performing or furnishing any of the Work.

9.13.4. Engineer's review of the final Application for Payment and accompanying documentation and all maintenance and operating instructions, schedules, guarantees, bonds and certificates of inspection, tests, and approvals and Other documentation required to be delivered by paragraph 14.12 will only be to determine generally that their content complies with the requirements of, and in the case of, certificates of inspections, tests and approvals that the results certified indicate compliance with the Contract Documents.

9.13.5. the limitations upon authority and responsibility set forth in this paragraph 9.13 shall also apply to Engineer's Consultants, Resident Project Representative and assistants.

ARTICLE 10 – CHANGES IN THE WORK

10.1. Without invalidating the Agreement and without notice to any surety, Owner may, at any time or from time to time, order additions, deletions or revisions in the Work. Such additions, deletions or revisions will be authorized by a Written Amendment, a Change Order, or a Work Change Directive. Upon receipt of any such document, Contractor shall promptly proceed with the Work involved which will be performed under the applicable conditions of the Contract Documents (except as otherwise specifically provided).

10.2. If Owner and Contractor are unable to agree as to the extent, if any, of an adjustment in the Contract Price or an adjustment of the Contract Times that should be allowed as a result of a Work Change Directive, a claim may be made therefore as provided in Article 11 or Article 12.

10.3. Contractor shall not be entitled to an increase in the Contract Price or an extension of the Contract Times with respect to any Work performed that is not required by the Contract Documents as amended, modified and supplemented as provided in paragraphs 3.5 and 3.6 except in the case of an emergency as provided in paragraph 6.23 or in the case of uncovering Work as provided in paragraph 13.9.

10.4. Owner and Contractor shall execute appropriate Change Orders recommended by Engineer covering:

10.4.1. changes in the Work which are (i) ordered by Owner pursuant to paragraph 10.1, (ii) required because of acceptance of defective Work under paragraph 13.13 or correcting defective Work under paragraph 13.14, or (iii) agreed to by the parties;

10.4.2. changes in the Contract Price or Contract Times which are agreed to by the parties; and

10.4.3. changes in the Contract Price or Contract Times which embody the substance of any written decision rendered by Engineer pursuant to paragraph 9.9;

Provided that, in lieu of executing any such Change Order, an appeal may be taken from any such decision in accordance with the provisions of the Contract Documents and applicable Laws and Regulations, but during any such appeal, Contractor shall carry on the Work and adhere to the progress schedule as provided in paragraph 6.21.

10.5. If notice of any change affecting the general scope of the Work or the provisions of the Contract Documents (including, but not limited to, Contract Price or Contract Times) is required by the provisions of any Bond to be given to a surety, the giving of any such notice will be Contractor's responsibility, and the amount of each applicable Bond will be adjusted accordingly.

ARTICLE 11 – CHANGE OF CONTRACT PRICE

11.1. The Contract Price constitutes the total compensation (subject to authorized adjustments) payable to Contractor for performing the Work. All duties, responsibilities and obligations assigned to or undertaken by Contractor shall be at Contractor's expense without change in the Contract Price.

11.2. The Contract Price may only be changed by a Change Order. Any claim for an adjustment in the Contract Price shall be based on written notice delivered by the party making the claim to the other party and to Engineer promptly (but in no event later than ten days) after the start of the occurrence or event giving rise to the claim and stating the general nature of the claim. Notice of the amount of the claim with supporting data shall be delivered within thirty days after the start of such occurrence or event (unless Engineer allows additional time for claimant to submit additional or more accurate data in support of the claim) and shall be accompanied by claimant's written statement that the adjustment claimed covers all known amounts to which the claimant is entitled as a result of said occurrence or event. All claims for adjustment in the Contract Price shall be determined by Engineer in accordance with paragraph 9.8 if Owner and Contractor cannot otherwise agree on the amount involved. No claim for an adjustment in the Contract Price will be valid if not submitted in accordance with this paragraph 11.2.

11.3 The value of any Work covered by a Change Order or of any claim for an adjustment in the Contract Price will be determined as follows:

11.3.1. where the Work involved is covered by unit prices contained in the Contract Documents, by application of such unit prices to the quantities of the items involved (subject to the provisions of paragraphs 11.9.1. through 11.9.3. inclusive);

11.3.2. where the Work involved is not covered by unit prices contained in the Contract Documents, by a mutually agreed lump sum (which may include an allowance for overhead and profit not necessarily in accordance with paragraph 11.6.2):

11.3.3. where the Work involved is not covered by unit prices contained in the Contract Documents and agreement to a lump sum is not reached under paragraph 11.3.2, on the basis of the Cost of the Work (determined as provided in paragraphs 11.4 and 11.5) plus a Contractor's fee for overhead and profit (determined as provided in paragraph 11.6).

Cost of the Work Covered by a Change Order:

11.4. The term Cost of the Work means the sum of all costs necessarily incurred and paid by Contractor in the proper performance of the Work. Except as otherwise may be agreed to in writing by Owner, such costs shall be in amounts no higher than those prevailing in the locality of the Project, shall include only the following items and shall not include any of the costs itemized in paragraph 11.5.

11.4.1. Payroll costs for employees in the direct employ of Contractor in the performance of the Work under schedules of job classifications agreed upon by Owner and Contractor. Such employees shall include without limitation superintendents, foremen and other personnel employed full-time at the site. Payroll costs for employees not employed full-time on the Work shall be apportioned on the basis of their time spent on the Work. Payroll costs shall include, but not be limited to, salaries and wages plus the cost of fringe benefits which shall include social security contributions, unemployment, excise and payroll taxes, workers' compensation, health and retirement benefits, bonuses, sick leave, vacation and holiday pay applicable thereto. The expenses of performing Work after regular working hours, on Saturday, Sunday or legal holidays, shall be included in the above to the extent authorized by Owner.

11.4.2. Cost of all materials and equipment furnished and incorporated in the Work, including costs of transportation and storage thereof, and Suppliers' field services required in connection therewith. All cash discounts shall accrue to Contractor unless Owner deposits funds with Contractor with which to make payments, in which case the cash discounts shall accrue to Owner. All trade discounts, rebates and refunds and returns from sale of surplus materials and equipment shall accrue to Owner, and Contractor shall make provisions so that they may be obtained.

11.4.3. Payments made by Contractor to the Subcontractors for Work performed or furnished by Subcontractors. If required by Owner, Contractor shall obtain competitive bids from subcontractors acceptable to Owner and Contractor and shall deliver such bids to Owner who will then determine, with the advice of Engineer, which bids, if any, will be accepted. If any subcontract provides that the Subcontractor is to be paid on the basis of Cost of the Work Plus a fee, the Subcontractor's Cost of the Work and fee shall be determined in the same manner as Contractor's Cost of the Work and fee as provided in paragraphs 11.4, 11.5, 11.6 and 11.7. All subcontracts shall be subject to the other provisions of the Contract Documents insofar as applicable.

11.4.4. Costs of special consultants (including but not limited to engineers, architects, testing laboratories, surveyors, attorneys and accountants) employed for services specifically related to the Work.

11.4.5. Supplemental costs including the following:

11.4.5.1. The proportion of necessary transportation, travel and subsistence expenses of Contractor's employees incurred in discharge of duties connected with the Work.

11.4.5.2. Cost, including transportation and maintenance, of all materials, supplies, equipment, machinery, appliances, office and temporary facilities at the site and hand tools not owned by the workers, which are consumed in the performance of the Work, and cost less market value of such items used but not consumed which remain the property of Contractor.

11.4.5.3. Rentals of all construction equipment and machinery and the parts thereof whether rented from Contractor or others in accordance with rental agreements approved by Owner with the advice of Engineer, and the costs of transportation, loading, unloading, installation, dismantling and removal thereof – all in accordance with the terms of said rental agreements. The rental of any such equipment, machinery or parts shall cease when the use thereof is no longer necessary for the Work.

11.4.5.4. Sales, consumer, use or similar taxes related to the work, and for which Contractor is liable, imposed by Laws and Regulations.

11.4.5.5. Deposits lost for causes other than negligence of Contractor, any Subcontractor or anyone directly or indirectly employed by any of them or for whose acts any of them may be liable, and royalty payments and fees for permits and licenses.

11.4.5.6. Losses and damages (and related expenses) caused by damage to the Work, not compensated by insurance or otherwise, sustained by Contractor in connection with the performance and furnishing of the Work (except losses and damages within the deductible amounts of property insurance established by Owner in accordance with paragraph 5.9), provided they have resulted from causes other than the negligence of Contractor, any Subcontractor, or anyone directly or indirectly employed by any of them or for whose acts any of them may be liable. Such losses shall include settlements made with the written consent and approval of Owner. No such losses, damages and expenses shall be included in the Cost of the Work for the purpose of determining Contractor's fee. If, however, any such loss or damage requires reconstruction and Contractor is placed in charge thereof, Contractor is placed in charge thereof, Contractor shall be paid for services a fee proportionate to that stated in paragraph 11.6.2.

11.4.5.7. The cost of utilities, fuel and sanitary facilities at the site.

11.4.5.8. Minor expenses such as telegrams, long distance telephone calls, telephone service at the site, expressage and similar petty cash items in connection with the Work.

11.4.5.9. Cost of premiums for additional Bonds and insurance required because of changes in the Work.

11.5. The term Cost of the Work Covered by a Change Order shall not include any of the following:

11.5.1. Payroll costs and other compensation of Contractor's officers, executives, principals (of partnership and sole proprietorships), general managers, engineers, architects, estimators, attorneys, auditors, accountants, purchasing and contracting agents, expeditors, timekeepers, clerks and other personnel employed by Contractor whether at the site or in Contractor's principal or a branch office for general administration of the Work and not specifically included in the agreed upon schedule of

job classifications referred to in paragraph 11.4.1 or specifically covered by paragraph 11.4.4 – all of which are to be considered administrative costs covered by the Contractor's fee.

11.5.2. Expenses of Contractor's principal and branch offices other than Contractor's office at the site.

11.5.3. Any part of Contractor's capital expenses, including interest on Contractor's capital employed for the Work and charges against Contractor for delinquent payments.

11.5.4. Cost of premiums for all Bonds and for all insurance whether or not Contractor is required by the Contract Documents to purchase and maintain the same (except for the cost of premiums covered by subparagraph 11.4.5.9 above).

11.5.5. Costs due to the negligence of Contractor, any Subcontractor, or anyone directly or indirectly employed by any of them or for whose acts any of them may be liable, including but not limited to, the correction of defective Work, disposal of materials or equipment wrongly supplied and making good any damage to property.

Other overhead or general expense costs of any kind and the costs of any item not specifically and expressly included in paragraph 11.4.

11.6. The Contractor's fee allowed to Contractor for overhead and profit shall be determined as follows:

11.6.1. a mutually acceptable fixed fee; or

11.6.2. if a fixed fee is not agreed upon, then a fee based on the following percentages of the various portions of the Cost of the Work:

11.6.2.1. for costs incurred under paragraphs 11.4.1 and 11.4.2, the Contractor's fee shall be ten percent;

11.6.2.2. for costs incurred under paragraph 11.4.3, the Contractor's fee shall be five percent.

11.6.2.3. where one or more tiers of subcontracts are on the basis of Cost of the Work plus a fee and no fixed fee is agreed upon, the intent of paragraphs 11.4.1, 11.4.2, 11.4.3 and 11.6.2 is that the Subcontractor who actually performs or furnishes the Work, at whatever tier, will be paid a fee of ten percent of the costs incurred by such Subcontractor under paragraphs 11.4.1 and 11.4.2 and that any higher tier Subcontractor and Contractor will each be paid a fee of five percent of the amount paid to the next lower tier Subcontractor:

11.6.2.4. no fee shall be payable on the basis of costs itemized under paragraphs 11.4.4, 11.4.5 and 11.5;

11.6.2.5. the amount of credit to be allowed by Contractor to Owner for any change which results in a net decrease in cost will be the amount of the actual net decrease in cost plus a deduction in Contractor's fee by an amount equal to five percent of such net decrease; and

11.6.2.6. when both additions and credits are involved in any one change, the adjustment in Contractor's fee shall be computed on the basis of the net change in accordance with paragraphs 11.6.2.1 through 11.6.2.5, inclusive.

11.7. Whenever the cost of any work is to be determined pursuant to paragraphs 11.4 and 11.5, Contractor will establish and maintain records thereof in accordance with generally accepted accounting practices and submit in form acceptable to Engineer an itemized cost breakdown together with supporting data.

11.8. Not Used

11.9. Unit Price Work:

11.9.1. Where the Contract Documents provide that all or part of the Work is to be Unit Price Work, initially the Contract Price will be deemed to include for all Unit Price Work an amount equal to the sum of the established unit price for each separately identified item of Unit Price Work times the estimated quantity of each item as indicated in the Agreement. The estimated quantities of items of Unit Price Work are not guaranteed and are solely for the purpose of comparison of Bids and determining an initial Contract Price. Determinations of the actual quantities and classifications of Unit Price Work performed by Contractor will be made by Engineer in accordance with paragraph 9.10.

11.9.2. Each unit price will be deemed to include an amount considered by Contractor to be adequate to cover Contractor's overhead and profit for each separately identified item.

11.9.3. Owner or Contractor may make a claim for an adjustment in the Contract Price in accordance with Article 11 if:

11.9.3.1. the quantity of any item of Unit Price Work performed by Contractor differs materially and significantly from the estimated quantity of such item indicated in the Agreement; and

11.9.3.2. there is no corresponding adjustment with respect to any other item of Work; and

11.9.3.3. if Contractor believes that Contractor is entitled to an increase in Contract Price as a result of having incurred additional expense or Owner believes that Owner is entitled to a decrease in Contract Price and the parties are unable to agree as to the amount of any such increase or decrease.

ARTICLE 12 – CHANGE OF CONTRACT TIMES

12.1. The Contract Times (or Milestones) may only be changed by a Change Order or a Written Amendment. Any claim for an adjustment of the Contract Times (or Milestones) shall be based on written notice delivered by the party making the claim to the other party and to Engineer promptly (but in no event later than thirty days) after the occurrence of the event giving rise to the claim and stating the general nature of the claim. Notice of the extent of the claim with supporting data shall be delivered within sixty days after such occurrence (unless Engineer allows an additional period of time to ascertain more accurate data in support of the claim) and shall be accompanied by the claimant's written statement that the adjustment claimed is the entire adjustment to which the claimant has reason to

believe it is entitled as a result of the occurrence of said event. All claims for adjustment in the Contract Times (or Milestones) shall be determined by Engineer in accordance with paragraph 9.11 if Owner and Contractor cannot otherwise agree. No claim for an adjustment in the Contract Times (or Milestones) will be valid if not submitted in accordance with the requirements of this paragraph 12.1.

12.2. All time limits stated in the Contract Documents are of the essence of the Agreement.

12.3. Where Contractor is prevented from completing any part of the Work within the Contract Times (or Milestones) due to delay beyond the control of Contractor, the Contract Times (or Milestones) will be extended in an amount equal to the time lost due to such delay if a claim is made therefore as provided in paragraph 12.1. Delays beyond the control of Contractor shall include, but not be limited to, acts or neglect by Owner, acts or neglect of utility owners or other contractors performing other work as contemplated by Article 7, fires, floods, epidemics, abnormal weather conditions or acts of God. Delays attributable to and within the control of a Subcontractor or Supplier shall be deemed to be delays within the control of Contractor.

12.4. Should Contractor be obstructed or delayed in the prosecution of or completion of the Work as a result of unforeseeable causes beyond the control of Contractor, and not due to its fault or neglect, including but not restricted to acts of God or of the public enemy, acts of government, fires, floods, epidemics, quarantine regulation, strikes or lockouts, Contractor shall notify the Owner in writing within forty-eight (48) hours after the commencement of such delay, stating the cause or causes thereof, or be deemed to have waived any right which Contractor may have had to request a time extension.

12.5. No interruption, interference, inefficiency, suspension or delay in the commencement or progress of the Work from any cause whatever, including those for which the Owner may be responsible, in whole or in part, shall relieve Contractor of his duty to perform or give rise to any right to damages or additional compensation from the Owner. Contractor expressly acknowledges and agrees that it shall receive no damages for delay. Contractor's sole remedy, if any, against the Owner will be the right to seek an extension to the Contract Time; provided, however, the granting of any such time extension shall not be a condition precedent to the aforementioned "No Damage For Delay" provision. This paragraph shall expressly apply to claims for early completion, as well as to claims based on late completion.

ARTICLE 13 – TESTS AND INSPECTION: CORRECTION, REMOVAL OR ACCEPTANCE OF DEFECTIVE WORK

13.1. Notice of Defects: Prompt notice of all defective Work of which Owner or Engineer have actual knowledge will be given to Contractor. All defective Work may be rejected, corrected or accepted as provided in this Article 13.

Access to Work:

13.2. Owner, Engineer, Engineer's Consultants, other representatives and personnel of Owner, independent testing laboratories and governmental agencies with jurisdictional interests will have access to the Work at reasonable times for their observation, inspecting and testing. Contractor shall provide them proper and safe conditions for such access and advise them of Contractor's site safety procedures and programs so that they may comply therewith as applicable.

Tests and Inspections:

13.3. Contractor shall give Engineer timely notice of readiness of the Work for all required inspections, tests or approvals, and shall cooperate with inspection and testing personnel to facilitate required inspections or tests.

13.4. Contractor shall employ and pay for services of an independent testing laboratory to perform all Quality Control inspections, test or approvals required by the contract documents. Contractor shall allow the Engineer access to all work done in the project for Acceptance Testing by the owner. This testing will be in addition to Quality Control Testing required by the Contractor. Owner shall arrange and pay all costs associated with Acceptance Testing done by an independent testing laboratory of the Owners choosing except:

13.4.1. for inspections, tests or approvals covered by paragraph 13.5 below.

13.4.2. that costs incurred in connection with tests or inspections conducted pursuant to paragraph 13.9 below shall be paid as provided in said paragraph 13.9; and

13.4.3. as otherwise specifically provided in the Contract Documents.

13.4.4 Owner shall perform the following test as part of quality assurance / acceptance testing:

All material testing included in the Bidding Documents.

All other required testing is to be completed by the contractor as part of the contractor's quality control procedures and submittals. This section shall take precedence over all other sections that describe testing requirements.

13.5. If Laws or Regulations of any public body having jurisdiction require any Work (or part thereof) specifically to be inspected, tested or approved by an employee or other representative of such public body, Contractor shall assume full responsibility for arranging and obtaining such inspections, tests or approvals, pay all costs in connection therewith, and furnish Engineer the required certificates of inspection, or approval. Contractor shall also be responsible for arranging and obtaining and shall pay all costs in connection with any inspections, tests or approvals required for Owner's and Engineer's acceptance of materials or equipment to be incorporated in the Work, or of materials, mix designs, or equipment submitted for approval prior to Contractor's purchase thereof for incorporation in the Work. Quality Control Testing of materials and equipment shall be the responsibility of the Contractor who shall pay all costs associated with the required testing. Contractor shall provide the Engineer adequate advance notice of intended tests to allow the Engineer to be present during the Testing.

13.6. If any Work (or the work of others) that is to be inspected, tested or approved is covered by Contractor without written concurrence of Engineer, it must, if requested by Engineer, be uncovered for observation.

13.7. Uncovering Work as provided in paragraph 13.6 shall be at Contractor's expense unless Contractor has given Engineer timely notice of Contractor's intention to cover the same and Engineer has not acted with reasonable promptness in response to such notice.

Uncovering Work:

13.8. If any Work is covered contrary to the written request of Engineer, it must, if requested by Engineer, be uncovered for Engineer's observation and replaced at Contractor's expense.

13.9. If Engineer considers it necessary or advisable that covered Work be observed by Engineer or inspected or tested by others, Contractor, at Engineer's request, shall uncover, expose or otherwise make available for observation, inspection or testing as Engineer may require that portion of the Work in question, furnishing all necessary labor, material and equipment. If it is found that such Work is defective, Contractor shall pay all claims, costs, losses and damages caused by, arising out of or resulting from such uncovering, exposure, observation, inspection and testing and of satisfactory replacement or reconstruction (including but not limited to all costs of repair or replacement of work of others; and Owner shall be entitled to an appropriate decrease in the Contract Price, and, if the parties are unable to agree as to the amount thereof, may make a claim therefore as provided in Article 11. If, however, such Work is not found to be defective, Contractor shall be allowed an increase in the Contract Price or an extension of the Contract Times (or Milestones), or both, directly attributable to such uncovering, exposure, observation, inspection, testing, replacement and reconstruction; and, if the parties are unable to agree as to the amount or extent therefore, Contractor may make a claim therefore as provided in Articles 11 and 12.

Owner May Stop the Work:

13.10. If the Work is defective, or Contractor fails to supply sufficient skilled workers or suitable materials or equipment, or fails to furnish or perform the Work in such a way that the completed Work will conform to the Contract Documents, Owner may order Contractor to stop the Work, or any portion thereof, until the cause for such order has been eliminated; however, this right of Owner to stop the Work shall not give rise to any duty on the part of Owner to exercise this right for the benefit of Contractor or any surety or other party.

Correction or Removal of Defective Work:

13.11. If required by Engineer, Contractor shall promptly, as directed, either correct all defective Work, whether or not fabricated, installed or completed, or, if the Work has been rejected by Engineer, remove it from the site and replace it with Work that is not defective. Contractor shall pay all claims, costs, losses and damages caused by or resulting from such correction or removal (including but not limited to all costs of repair or replacement of work of others).

13.12. Correction Period:

13.12.1. If within one year after the date of Substantial Completion or such longer period of time as may be prescribed by Laws or Regulations or by the terms of any applicable special guarantee required by the Contract Documents or by any specific provision of the Contract Documents, any Work is found to be defective, Contractor shall promptly, without cost to Owner and in accordance with Owner's written instruction: (i) correct such defective Work, or, if it has been rejected by Owner, remove it from the site and replace it with Work that is not defective, and (ii) satisfactorily correct or remove and replace any damage to other Work or the work of others resulting therefrom. If Contractor does not promptly comply with the terms of such instructions, or in any emergency where delay would cause serious risk of loss or damage, Owner may have the defective Work corrected or

the rejected Work removed and replaced, and all claims, costs, losses and damages caused by or resulting from such removal and replacement (including but not limited to all costs of repair or replacement of work of others) will be paid by Contractor.

13.12.2. In special circumstances where a particular item of equipment is placed in continuous service before Substantial Completion of all the Work, the correction period for that item may start to run from an earlier date if so provided in the Specifications or by Written Amendment.

13.12.3. Where defective Work (and damage to other Work resulting therefrom) has been corrected, removed or replaced under this paragraph 13.12, the correction period hereunder with respect to such Work will be extended for an additional period of one year after such correction or removal and replacement has been satisfactorily completed.

Acceptance of Defective Work:

13.13 If, instead of requiring correction or removal and replacement of defective Work, Owner (and, prior to Engineer's recommendation of final payment, also Engineer) prefers to accept it, Owner may do so. Contractor shall pay all claims, costs, losses and damages attributable to Owner's evaluation of and determination to accept such defective Work (such costs to be approved by Engineer as to reasonableness). If any such acceptance occurs prior to Engineer's recommendation of final payment, a Change Order will be issued incorporating the necessary revisions in the Contract Documents with respect to the Work; and Owner shall be entitled to an appropriate decrease in the Contract Price, and, if the parties are unable to agree as to the amount thereof, Owner may make a claim therefore as provided in Article 11. If the acceptance occurs after such recommendation, an appropriate amount will be paid by Contractor to Owner.

Owner May Correct Defective Work:

13.14 If Contractor fails within a reasonable time after written notice from Engineer to correct defective Work or to remove and replace rejected Work as required by Engineer in accordance with paragraph 13.11, or if Contractor fails to perform the Work in accordance with the Contract Documents, or if Contractor fails to comply with any other provision of the Contract Documents, Owner may, after seven days' written notice to Contractor, correct and remedy any such deficiency. In exercising the rights and remedies under this paragraph Owner shall proceed expeditiously. In connection with such corrective and remedial action, Owner may exclude Contractor from all or part of the site, take possession of all or part of the Work, and suspend Contractor's services related thereto, take possession of Contractor's tools, appliances, construction equipment and machinery at the site and incorporate in the Work all materials and equipment stored at the site or for which Owner has paid Contractor but which are stored elsewhere. Contractor shall allow Owner, Owner's representative, agents and employees, Owner's other contractors and Engineer and Engineer's Consultants access to the site to enable Owner to exercise the rights and remedies under this paragraph. All claims, costs, losses and damages incurred or sustained by Owner in exercising such rights and remedies will be charged against Contractor and a Change Order will be issued incorporating the necessary revisions in the Contract Documents with respect to the Work; and Owner shall be entitled to an appropriate decrease in the Contract Price, and, if the parties are unable to agree as to the amount thereof, Owner may make a claim therefore as provided in Article 11. Such claims, costs, losses and damages will include but not be limited to all costs of repair or replacement of work of others destroyed or damaged by correction, removal or replacement of Contractor's defective Work. Contractor shall not be allowed an extension of

the Contract Times (or Milestones) because of any delay in the performance of the Work attributable to the exercise by Owner of Owner's rights and remedies hereunder.

ARTICLE 14 – PAYMENTS TO CONTRACTOR AND COMPLETION

Schedule of Values:

14.1. The schedule of values established as provided in paragraph 2.9 will serve as the basis for progress payments and will be incorporated into a form of Application for Payment acceptable to Engineer. Progress payments on account of Unit Price Work will be based on the number of units completed.

Application for Progress Payment:

14.2. At least ten days before the date established for each progress payment (but not more often than once a month), Contractor shall submit to Engineer for review an Application for Payment filled out and signed by Contractor covering the Work completed as of the date of the Application and accompanied by such supporting documentation as is required by the Contract Documents. If payment is requested on the basis of materials and equipment not incorporated in the Work but delivered and suitably stored at the site or at another location agreed to in writing, the Application for Payment shall also be accompanied by a bill of sale, invoice or other documentation warranting that Owner has received the materials and equipment free and clear of all Liens and evidence that the materials and equipment are covered by appropriate property insurance and other arrangements to protect Owner's interest therein, all of which will be satisfactory to Owner. The amount of retainage with respect to progress payments will be as stipulated in the Agreement.

Contractor's Warranty of Title:

14.3. Contractor warrants and guarantees that title to all Work, materials and equipment covered by any Application for Payment, whether incorporated in the Project or not, will pass to Owner no later than the time of payment free and clear of all Liens.

Review of Applications for Progress Payment:

14.4. Engineer will, within ~~ten~~ *fifteen (15)* days after receipt of each Application for Payment, either indicate in writing a recommendation of payment and present the Application to Owner, or return the Application to Contractor indicating in writing Engineer's reasons for refusing to recommend payment. In the latter case, Contractor may make the necessary corrections and resubmit the Application. ~~Ten~~ *Thirty (30)* days after presentation of the Application for Payment to Owner with Engineer's recommendation, the amount recommended will (subject to the provisions of the last sentence of paragraph 14.7) become due and when due will be paid by Owner to Contractor.

14.5. Engineer's recommendation of any payment requested in an Application for Payment will constitute a representation by Engineer to Owner, based on Engineer's on-site observations of the executed Work as an experienced and qualified design professional and on Engineer's review of the Application for Payment and the accompanying data and schedules, that to the best of Engineer's knowledge, information and belief:

14.5.1. the Work has progressed to the point indicated.

14.5.2. the quality of the Work is generally in accordance with the Contract Documents (subject to an evaluation of the Work as a functioning whole prior to or upon Substantial Completion, to the results of any subsequent tests called for in the Contract Documents, to a final determination of quantities and classifications for Unit Price Work under paragraph 9.8, and to any other qualifications stated in the recommendation), and

14.5.3. the conditions precedent to Contractor's being entitled to such payment appear to have been fulfilled in so far as it is Engineer's responsibility to observe the Work.

However, by recommending any such payment Engineer will not thereby be deemed to have represented that: (i) exhaustive or continuous on-site inspections have been made to check the quality or the quantity of the Work beyond the responsibilities specifically assigned to Engineer in the Contract Documents or (ii) that there may not be other matters or issues between the parties that might entitle Contractor to be paid additionally by Owner or entitle Owner to withhold payment to Contractor.

14.6. Engineer's recommendation of any payment, including final payment, shall not mean that Engineer is responsible for Contractor's means, methods, techniques, sequences or procedures of construction, or the safety precautions and programs incident thereto, or for any failure of Contractor to comply with Laws and Regulations applicable to the furnishing or performance of Work, or for any failure of Contractor to perform or furnish Work in accordance with the Contract Documents.

14.7. Engineer may refuse to recommend the whole or any part of any payment if, in Engineer's opinion, it would be incorrect to make the representations to Owner referred to in paragraph 14.5. Engineer may also refuse to recommend any such payment, or, because of subsequently discovered evidence or the results of subsequent inspections or tests, nullify any such payment previously recommended, to such extent as may be necessary in Engineer's opinion to protect Owner from loss because:

14.7.1. the Work is defective, or completed Work has been damaged requiring correction or replacement.

14.7.2. the Contract Price has been reduced by Written Amendment or Change Order.

14.7.3. Owner has been required to correct defective Work or complete Work in accordance with paragraph 13.14. or

14.7.4. Engineer has actual knowledge of the occurrence of any of the events enumerated in paragraphs 15.2.1 through 15.2.4 inclusive.

Owner may refuse to make payment of the full amount recommended by Engineer because:

14.7.5. claims have been made against Owner on account of Contractors performance or furnishing of the Work.

14.7.6. Liens have been filed in connection with the Work, except where Contractor has delivered a specific Bond satisfactory to Owner to secure the satisfaction and discharge of such Liens,

14.7.7. there are other items entitling Owner to a set-off against the amount recommended, or

14.7.8. Owner has actual knowledge of the occurrence of any of the events enumerated in paragraphs 14.7.1 through 14.7.3 or paragraphs 15.2.1 through 15.2.4 inclusive;

but Owner must give Contractor immediate written notice (with a copy to Engineer) stating the reasons for such action and promptly pay Contractor the amount so withheld, or any adjustment thereto agreed to by Owner and Contractor, when Contractor corrects to Owner's satisfaction the reasons for such action.

Substantial Completion:

14.8. When Contractor considers the entire Work ready for its intended use Contractor shall notify Owner and Engineer in writing that the entire Work is substantially complete (except for items specifically listed by Contractor as incomplete) and request that Engineer issue a certificate of Substantial Completion. Within a reasonable time thereafter, Owner, Contractor and Engineer shall make an inspection of the Work to determine the status of completion. If Engineer does not consider the Work substantially complete, Engineer will notify Contractor in writing giving the reasons therefore. If Engineer considers the Work substantially complete, Engineer will prepare and deliver to Owner a tentative certificate of Substantial Completion which shall fix the date of Substantial Completion. There shall be attached to the certificate a tentative list of items to be completed or corrected before final payment. Owner shall have seven days after receipt of the tentative certificate during which to make written objection to Engineer as to any provisions of the certificate or attached list. If, after considering such objections, Engineer concludes that the Work is not substantially complete, Engineer will within fourteen days after submission of the tentative certificate to Owner notify Contractor in writing, stating the reasons therefore. If, after consideration of Owner's objections, Engineer considers the Work substantially complete, Engineer will within said fourteen days execute and deliver to Owner and Contractor a definitive certificate of Substantial Completion (with a revised tentative list of items to be completed or corrected) reflecting such changes from the tentative certificate as Engineer believes justified after consideration of any objections from Owner. At the time of delivery of the tentative certificate of Substantial Completion Engineer will deliver to Owner and Contractor a written recommendation as to division of responsibilities pending final payment between Owner and Contractor with respect to security, operation, safety, maintenance, heat, utilities, insurance and warranties and guarantees. Unless Owner and Contractor agree otherwise in writing and so inform Engineer in writing prior to Engineer's issuing the definitive certificate of Substantial Completion, Engineer's aforesaid recommendation will be binding on Owner and Contractor until final payment.

14.9. Owner shall have the right to exclude Contractor from the Work after the date of Substantial Completion, but Owner shall allow Contractor reasonable access to complete or correct items on the tentative list.

Partial Utilization:

14.10. Use by Owner at Owner's option of any substantially completed part of the Work which: (i) has specifically been identified in the Contract Documents, or (ii) Owner, Engineer and Contractor agree constitutes a separately functioning and usable part of the Work that can be used by Owner for its

intended purpose without significant interference with Contractor's performance of the remainder of the Work, may be accomplished prior to Substantial Completion of all the Work subject to the following:

14.10.1. Owner at any time may request Contractor in writing to permit Owner to use any such part of the Work which Owner believes to be ready for its intended use and substantially complete. If Contractor agrees that such part of the Work is substantially complete, Contractor will certify to Owner and Engineer that such part of the Work is substantially complete and request Engineer to issue a certificate of Substantial Completion for that part of the Work. Contractor at any time may notify Owner and Engineer in writing that Contractor considers any such part of the Work ready for its intended use and substantially complete and request Engineer to issue a certificate of Substantial Completion for that part of the Work. Within a reasonable time after either such request, Owner, Contractor and Engineer shall make an inspection of that part of the Work to determine its status of completion. If Engineer does not consider that part of the Work to be substantially complete, Engineer will notify Owner and Contractor in writing giving the reasons therefore. If Engineer considers that part of the Work to be substantially complete, the provisions of paragraphs 14.8 and 14.9 will apply with respect to certification of Substantial Completion of that part of the Work and the division of responsibility in respect thereof and access thereto.

14.10.2. No occupancy or separate operation of part of the Work will be accomplished prior to compliance with the requirements of paragraph 5.6 in respect of property insurance.

Owner may at any time request Contractor in writing to permit Owner to take over operation of any such part of the work although it is not substantially complete. A copy of such request will be sent to Engineer and within a reasonable time thereafter Owner, Contractor, and Engineer shall make an inspection of that part of the Work to determine its status of completion and will prepare a list of the items remaining to be completed or corrected thereon before final payment. If Contractor does not object in writing to Owner and Engineer that such part of the Work is not ready for separate operation by Owner, Engineer will finalize the list if items to be completed or corrected and will deliver such lists to Owner and Contractor together with a written recommendation as to the division of responsibilities pending final payment between Owner and Contractor with respect to security, operation, safety, maintenance, utilities, insurance, warranties and guarantees for that part of the Work which will become binding upon Owner and Contractor at the time when Owner takes over such operation (unless they shall have otherwise agreed in writing and so informed Engineer). During such operation and prior to Substantial Completion of such part of the Work, Owner shall allow Contractor reasonable access to complete or correct items on said list and to complete other related Work.

Final Inspection:

14.11. Upon written notice from Contractor that the entire Work or an agreed portion thereof is complete, Engineer will make a final inspection with Owner and Contractor and will notify Contractor in writing of all particulars in which this inspection reveals that the Work is incomplete or defective. Contractor shall immediately take such measures as are necessary to complete such Work or remedy such deficiencies.

Final Application for Payment:

14.12. After Contractor has completed all such corrections to the satisfaction of Engineer and delivered in accordance with the Contract Documents all maintenance and operating instructions, schedules,

guarantees, Bonds, certificates or other evidence of insurance required by paragraph 5.4, certificates of inspection, marked-up record documents (as provided in paragraph 6.14) and other documents, Contractor may make application for final payment following the procedure for progress payments. The final Application for Payment shall be accompanied (except as previously delivered) by:

(i) consent of the surety, if any, to final payment.

(ii) complete and legally effective releases or waivers (satisfactory to Owner) of all Liens arising out of or filed in connection with the Work. In lieu of such releases or waivers of Liens and as approved by Owner, Contractor may furnish receipts or releases in full and an affidavit of Contractor that: (i) the releases and receipts include all labor, services, material and equipment for which a Lien could be filed, and (ii) all payrolls, material and equipment bills and other indebtedness connected with the Work for which Owner or Owner's property might in any way be responsible have been paid or otherwise satisfied. If any Subcontractor or Supplier fails to furnish such a release or receipt in full, Contractor may furnish a Bond or other collateral satisfactory to Owner to indemnify Owner against any Lien.

(iii) certification from surety that payment and performance bond shall remain in effect one (1) year following final payment.

(iv) contractor's advertisement of completion – advertisement for a period of four (4) successive weeks in the newspaper or largest circulation published within the county where the work is performed.

(v) certification from insurance company that any insurance coverage written on a claims-made basis, remain in effect for at least two (2) years following final payment.

Final Payment and Acceptance:

14.13. If, on the basis of Engineer's observation of the Work during construction and final inspection, and Engineer's review of the final application for Payment and accompanying documentation as required by the Contract Documents, Engineer is satisfied that the Work has been completed and Contractor's other obligations under the Contract Documents have been fulfilled, Engineer will, within ten days after receipt of the final Application for Payment, indicate in writing Engineer's recommendation of payment and present the Application to Owner for payment. At the same time Engineer will also give written notice to Owner and Contractor that the Work is acceptable subject to the provisions of paragraph 14.15. Otherwise, Engineer will return the Application to Contractor, indicating in writing the reasons for refusing to recommend final payment, in which case Contractor shall make the necessary corrections and resubmit the Application. Thirty days after the presentation to Owner of the Application and accompanying documentation, in appropriate form and substance and with Engineer's recommendation and notice of acceptability, the amount recommended by Engineer will become due and will be paid by Owner to Contractor

14.14. If, through no fault of Contractor, final completion of the Work is significantly delayed and if Engineer so confirms, Owner shall, upon receipt of Contractor's final Application for Payment and recommendation of Engineer, and without terminating the Agreement, make payment of the balance due for that portion of the Work fully completed and accepted. If the remaining balance to be held by Owner for Work not fully completed or corrected is less than the retainage stipulated in the Agreement, and if Bonds have been furnished as required in paragraph 5.1, the written consent of the surety to the payment of the balance due for that portion of the Work fully completed and accepted shall be submit-

ted by Contractor to Engineer with the Application for such payment. Such payment shall be made under the terms and conditions governing final payment, except that it shall not constitute a waiver of claims.

Waiver of Claims:

14.15. The making and acceptance of final payment will constitute:

14.15.1. a waiver of all claims by Owner against Contractor, except claims arising from unsettled Liens, from defective Work appearing after final inspection pursuant to paragraph 14.11, from failure to comply with the Contract Documents or the terms of any special guarantees specified therein, or from Contractor's continuing obligations under the Contract Documents; and

14.15.2. a waiver of all claims by Contractor against Owner other than those previously made in writing and still unsettled.

ARTICLE 15 – SUSPENSION OF WORK AND TERMINATION

Owner May Suspend Work:

15.1. At any time and without cause, Owner may suspend the Work or any portion thereof for a period of not more than ninety days by notice in writing to Contractor and Engineer which will fix the date on which Work will be resumed. Contractor shall resume the Work on the date so fixed. Contractor shall be allowed an adjustment in the Contract Price or an extension of the Contract Times, or both, directly attributable to any such suspension if Contractor makes an approved claim therefore as provided in Articles 11 and 12.

Owner May Terminate:

15.2. Upon the occurrence of any one or more of the following events:

15.2.1. if Contractor persistently fails to perform the Work in accordance with the Contract Documents (including, but not limited to, failure to supply sufficient skilled workers or suitable materials or equipment or failure to adhere to the progress schedule established under paragraph 2.9 as adjusted from time to time pursuant to paragraph 6.6);

15.2.2. if Contractor disregards Laws or Regulations of any public body having jurisdiction;

15.2.3. if Contractor disregards the authority of Engineer; or

15.2.4. if Contractor otherwise violates in any substantial way any provisions of the Contract Documents;

15.2.5. if Contractor commences a voluntary case under any chapter of the Bankruptcy Code (Title 11, United States Code), as now or hereafter in effect, or if Contractor takes any equivalent or similar action by filing a petition or otherwise under any other federal or state law in effect at such time relating to the bankruptcy or insolvency;

15.2.5.1 if a petition is filed against Contractor under any chapter of the Bankruptcy Code (Title 11, United States Code), as now or hereafter in effect at the time of filing, or if a petition is filed seeking any such equivalent or similar relief against Contractor under any other federal or state law in effect at the time relating to bankruptcy or insolvency;

15.2.5.2 if Contractor makes a general assignment for the benefit of creditors;

15.2.5.3 if a trustee, receiver, custodian, or agent of Contractor is appointed under applicable law or under contract, whose appointment or authority to take charge of property of Contractor is for the purpose of enforcing a Lien against such property or for the purpose of general administration of such property for the benefit of Contractor's creditors;

15.2.5.4 if Contractor admits in writing an inability to pay its debts generally as they become due.

Owner may, after giving Contractor (and the surety, if any,) seven days' written notice and to the extent permitted by Laws and Regulations, terminate the services of Contractor, exclude Contractor from the site and take possession of the Work and of all Contractor's tools, appliances, construction equipment and machinery at the site and use the same to the full extent they could be used by Contractor (without liability to Contractor for trespass or conversion), incorporate in the Work all materials and equipment stored at the site or for which Owner has paid Contractor but which are stored elsewhere, and finish the Work as Owner may deem expedient. In such case Contractor shall not be entitled to receive any further payment until the Work is finished. If the unpaid balance of the Contract Price exceeds all claims, costs, losses and damages sustained by Owner arising out of or resulting from completing the Work such excess will be paid to Contractor. If such claims, costs, losses and damages exceed such unpaid balance, Contractor shall pay the difference to Owner. Such claims, costs, losses and damages incurred by Owner will be reviewed by Engineer as to their reasonableness and when so approved by Engineer incorporated in a Change Order, provided that when exercising any rights or remedies under this paragraph Owner shall not be required to obtain the lowest price for the Work performed.

15.3. Where Contractor's services have been so terminated by Owner, the termination will not affect any rights or remedies of Owner against Contractor then existing or which may thereafter accrue. Any retention or payment of moneys due Contractor by Owner will not release Contractor from liability.

15.4. Upon seven days' written notice to Contractor and Engineer, Owner may, without cause and without prejudice to any other right or remedy of Owner, elect to terminate the Agreement. In such case, Contractor shall be paid (without duplication of any items):

15.4.1. for completed and acceptable Work executed in accordance with the Contract Documents prior to the effective date of termination, including fair and reasonable sums for overhead and profit on such Work;

15.4.2. for expenses sustained prior to the effective date of termination in performing services and furnishing labor, materials or equipment as required by the Contract Documents in connection with uncompleted Work, plus fair and reasonable sums for overhead and profit on such expenses;

15.4.3. for all claims, costs, losses and damages incurred in settlement of terminated contracts with Subcontractors, Suppliers and other; and

15.4.4. for reasonable expenses directly attributable to termination.

Contractor shall not be paid on account of loss of anticipated profits or revenue or other economic loss arising out of or resulting from such termination.

Contractor May Stop Work or Terminate:

15.5. If, through no act or fault of Contractor, the Work is suspended for a period of more than ninety days by Owner or under an order of court or other public authority, or Engineer fails to act on any Application for Payment within thirty days after it is submitted or Owner fails for thirty days to pay Contractor any sum finally determined to be due, then Contractor may, upon seven days' written notice to Owner and Engineer, and provided Owner or Engineer do not remedy such suspension or failure within that time, terminate the Agreement and recover from Owner payment on the same terms as provided in paragraph 15.4. In lieu of terminating the Agreement and without prejudice to any other right or remedy, if Engineer has failed to act on an Application for Payment within thirty days after it is submitted, or Owner has failed for thirty days to pay Contractor any sum finally determined to be due, Contractor may upon seven day's written notice to Owner and Engineer stop the Work until payment of all such amounts due Contractor, including interest thereon. The provisions of this paragraph 15.5 are not intended to preclude Contractor from making claim under Articles 11 and 12 for an increase in Contract Price or Contract Times or otherwise for expenses or damage directly attributable to Contractor's stopping Work as permitted by this paragraph.

ARTICLE 16 – MISCELLANEOUS

16.1 Giving Notice:

Whenever any provision of the Contract Documents requires the giving of written notice, it will be deemed to have been validly given if delivered in person to the individual or to a member of the firm or to an officer of the corporation for whom it is intended, or if delivered at or sent by registered or certified mail, postage prepaid, to the last business address known to the giver of the notice.

16.2 Computation of Times:

16.2.1. When any period of time is referred to in the Contract Documents by days, it will be computed to exclude the first and include the last day of such period. If the last day of any such period falls on a Saturday or Sunday or on a day made a legal holiday by the law of the applicable jurisdiction, such day will be omitted from the computation.

16.2.2. A calendar day of twenty-four hours measured from midnight to the next midnight will constitute a day.

16.3. Notice of Claim:

Should Owner or Contractor suffer injury or damage to person or property because of any error, omission or act of the other part or of any of the other party's employees or agents or others for whose acts the other party is legally liable, claim will be made in writing to the other party promptly, but in no event later than fifteen (15) days of the first observance of such injury or damage. The provisions of this

paragraph 16.3 shall not be construed as a substitute for or a waiver of the provisions of any applicable statute of limitations or repose.

16.4. Cumulative Remedies:

The duties and obligations imposed by these General Conditions and the rights and remedies available hereunder to the parties hereto, and, in particular but without limitation, the warranties, guarantees and obligations imposed upon Contractor by paragraphs 6.2, 6.13, 6.22, 6.23, 13.1, 13.12, 13.14, 14.3 and 15.2 and all of the rights and remedies available to Owner and Engineer thereunder, are in addition to, and are not to be construed in any way as a limitation of, any rights and remedies available to any or all of them which are otherwise imposed or available by Laws or Regulations, by special warranty or guarantee or by other provisions of the Contract Documents, and the provisions of this paragraph will be as effective as if repeated specifically in the Contract Documents in connection with each particular duty, obligation, right and remedy to which they apply.

16.5. Professional Fees and Court Costs Included:

Whenever reference is made to "claims, costs, losses and damages," it shall include in each case, but not be limited to, all fees and charges of engineers, architects, attorneys and other professionals and all court or other dispute resolution costs.

16.6. Labor Records and Schedules:

The Department of Jurisdiction on such public work shall require all Contractors and Subcontractors to keep the following records on the site of the public work project on which such Contractors, and Subcontractors are engaged:

16.6.1 Record of hours worked by each worker, laborer, and mechanic on each day.

16.6.2 Record of days worked each week by each worker, laborer, and mechanic.

16.6.3 Schedule of occupation or occupations at which each worker, laborer, and mechanic on the project is employed during each workday and week.

16.6.4 Schedule of hourly wage rates and supplements paid to each worker, laborer, and mechanic for each occupation.

16.7. Wage Schedules:

Pursuant to the Labor Law, each laborer, worker, or mechanic employed by the Contractor, Subcontractor, or other person shall be paid not less than the prevailing rate of wages for a legal day's work and shall be provided supplements not less than the prevailing supplements as determined by the Industrial Commissioner.

The Contractor and every Subcontractor shall post in a prominent and accessible place on the site of the work a legible statement of all wage rates and supplements as specified in the Contract to be paid or provided, as the case may be, for the various classes of mechanics, workers, and laborers employed on the work.

The Owner does not represent or warrant that the accompanying schedule of wage rates and supplements with the classification of workers, mechanics, and laborers, as required the Labor Law, is complete, and it reserves the right to revise such schedule when required. If any occupation is not mentioned in the schedule of wage rates and supplements it shall be requested from the Industrial Commissioner, by the Contractor through the Engineer and such schedules, shall, upon notice to the Contractor, become and be a part of the wage and supplement schedules embodied in the Contract.

Also included is the Federal Wage Rate Determination. Laborers, workmen, and mechanics employed on the work done in performance of said Contract shall be paid not less than the rate of wages listed thereon for the trade or occupation of such laborer, etc.

DESTIN-FORTWALTON BEACH AIRPORT FUEL FARM FALL PROTECTION ADDITIONS

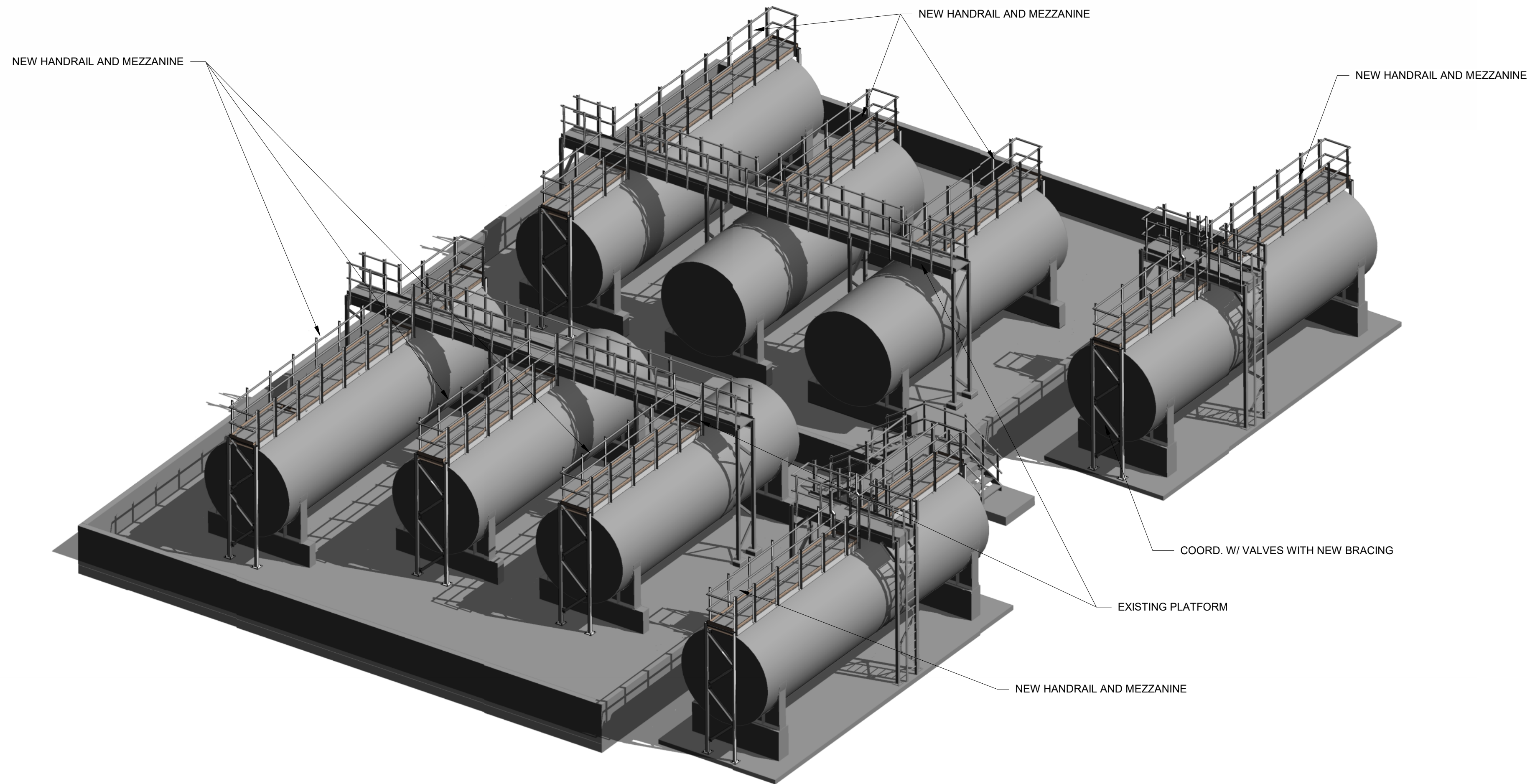

1 VIEW OF PLATFORMS

NOTES:

1. CONTRACTOR SHALL REVIEW SHOP DRAWINGS FOR TANKS AND COORDINATE WITH MANUFACTURER FOR DEFUELING THE TANKS. IF REQUIRED, THE CONTRACTOR SHALL PROVIDE A WRITTEN LETTER FROM THE MANUFACTURER.
2. THE CONTRACTOR SHALL PROVIDE NECESSARY MEASURES FOR ALL FIELD WELDING AND BOLTING AROUND TANKS. THE TANKS INSIDE THE CONTAINMENT AREA WILL NOT BE DE-FUELED PRIOR TO CONSTRUCTION OF PLATFORMS. THE CONTRACTOR SHALL FOLLOW ALL FBC, NFPA, AND INTERNATIONAL FIRE CODE FOR WORKING AROUND TANKS. A PLAN SHALL BE SUBMITTED TO THE AIRPORT FOR REVIEW PRIOR TO ANY WORK BEING PERFORMED.
3. SEE THE BID SCHEDULE FOR THE VPS FALL PROTECTION PROJECT. THE BIDS WILL BE ORGANIZED AS FOLLOWS:
 - A. BASE BID - NEW CATWALKS FOR TANKS 1 THROUGH 6
 - B. ADDITIVE ALTERNATE NO. 1 - CATWALKS FOR TANKS 7 AND 8
 - C. ADDITIVE ALTERNATE NO. 2 - PAD-EYES FOR TANKS 7 AND 8 WITHOUT ADDITIONAL CATWALKS FOR TANKS 7 AND 8.
4. THE COUNTY BUILDING DEPARTMENT WILL REQUIRE A PERMIT FOR THIS PROJECT. THE CONTRACTOR SHALL PROVIDE ALL NECESSARY PAPERWORK AND COORDINATION WITH THE COUNTY TO PROCURE A PERMIT AND CLOSE OUT THE PERMIT AS REQUIRED BY THE BUILDING OFFICIAL.

SHEET INDEX		
SHEET NO.	SHEET REF.	TITLE
1	S-101	STRUCTURAL INFORMATION
1	T-001	COVER SHEET
2	S-001	GENERAL NOTES
3	S-100	FRAMING PLAN
4	S-200	STRUCTURAL SECTIONS
5	S-201	STRUCTURAL DETAILS

OKALOOSA COUNTY
AIRPORTS



AVCON, INC.
ENGINEERS & PLANNERS

320 BAYSHORE DRIVE, SUITE A - NICEVILLE, FL 32578-2425
OFFICE: (850) 878-0550 - FAX: (850) 678-0340
CORPORATE CERTIFICATE OF AUTHORIZATION NUMBER: 5057
www.avconinc.com



McCarthy
ENGINEERING

FL. CA LICENSE NUMBER #29241
214 E. Government St.
Pensacola, Florida 32502
P: (850) 475-1268 F: (850) 502-4210
MEI project: 2017-166

DESTIN-FORT
WALTON BEACH
AIRPORT

FUEL FARM FALL
PROTECTION

COVER SHEET

ATTENTION:

THIS DOCUMENT CONTAINS PRIVILEGED AND PROPRIETARY INFORMATION, ALL OF WHICH IS EXPRESSLY PROVIDED BY AVCON, INC., FOR USE BY THE INTENDED RECIPIENT, AND FOR A SPECIFIC PURPOSE. WITHOUT THE EXPRESS WRITTEN CONSENT OF AVCON, INC. ANY DISTRIBUTION, REPRODUCTION, OR OTHER USE OF THIS DOCUMENT, IN WHOLE OR IN PART, IS STRICTLY PROHIBITED.

SCALE:

REVISIONS:

NO.	DATE	BY	DESCRIPTION

100% NOT FOR CONSTRUCTION

DESIGNED BY: DJM
DRAWN BY: WEH
CHECKED BY: DJM
APPROVED BY: DJM
DATE: 8/14/2019

AVCON PROJECT NO. 2017.050.02

SHEET NUMBER

T-001

STRUCTURAL - GENERAL NOTES

- TO THE BEST OF OUR KNOWLEDGE, THE STRUCTURAL PLANS AND SPECIFICATIONS COMPLY WITH THE APPLICABLE REQUIREMENTS OF THE FOLLOWING GOVERNING DESIGN CODES:
 - FLORIDA BUILDING CODE 2017 EDITION
 - AISC STEEL CONSTRUCTION MANUAL (14TH EDITION)
 - BUILDING CODE REQUIREMENTS FOR STRUCTURAL CONCRETE, (ACI 318-14)
 - MINIMUM DESIGN LOADS FOR BUILDINGS AND OTHER STRUCTURES (ASCE 7-10)
 - STRUCTURAL WELDING CODE AWS D1.1, 2008
- THE STRUCTURAL DOCUMENTS ARE TO BE USED IN CONJUNCTION WITH THE MECHANICAL, ELECTRICAL, PLUMBING AND CIVIL DOCUMENTS. USE THESE NOTES IN CONJUNCTION WITH THE PROJECT SPECIFICATIONS. IF A CONFLICT EXISTS, THE MORE STRINGENT GOVERNS.
- SEE PROJECT SPECIFICATIONS FOR TESTING.
- THE CONTRACTOR SHALL REVIEW ALL CONTRACT DOCUMENTS; INCLUDING DIMENSIONS, AND SITE CONDITIONS AND COORDINATE WITH FIELD DIMENSIONS AND PROJECT SHOP DRAWINGS PRIOR TO CONSTRUCTION. ANY AND ALL DISCREPANCIES SHALL BE SUBMITTED IN WRITING TO ARCHITECT / ENGINEER. DO NOT MODIFY OR CHANGE THE SIZE OR DIMENSIONS OF STRUCTURAL MEMBERS WITHOUT WRITTEN INSTRUCTIONS FROM THE STRUCTURAL ENGINEER OF RECORD.
- IT SHALL BE THE RESPONSIBILITY OF THE SUBCONTRACTOR TO LOCATE ANY AND ALL EXISTING UTILITIES WHETHER SHOWN HEREON OR NOT, AND TO PROTECT EXISTING FACILITIES, STRUCTURES AND UTILITY LINES FROM ALL DAMAGE. EACH CONTRACTOR SHALL PROTECT HIS WORK, ADJACENT PROPERTY AND THE PUBLIC. EACH CONTRACTOR IS SOLELY RESPONSIBLE FOR DAMAGE OR INJURY DUE TO HIS ACT OR NEGLIGENCE.
- WHERE A CONSTRUCTION DETAIL IS NOT SHOWN OR NOTED, THE DETAIL SHALL BE THE SAME AS FOR OTHER SIMILAR WORK. DETAILS LABELED "TYPICAL DETAILS" ON THE DRAWINGS APPLY TO ALL SITUATIONS THAT ARE THE SAME OR SIMILAR TO THOSE SPECIFICALLY DETAILED. ANY QUESTIONS REGARDING APPLICABILITY OF TYPICAL DETAILS SHALL BE RESOLVED BY THE ARCHITECT / ENGINEER.
- DESIGN LOAD CRITERIA:
 - STRUCTURE RISK CATEGORY (IBC 1604.5) IV
 - GRAVITY LOADS:
 - CATWALK LIVE LOAD 100 PSF
 - DEAD LOAD 20 PSF
 - WIND LOADS:
 - ULTIMATE DESIGN WIND SPEED 153 MPH
 - NOMINAL DESIGN WIND SPEED 119 MPH
 - WIND EXPOSURE CATEGORY C
 - INTERNAL PRESSURE COEFFICIENT ±0.18 (ENCLOSED)
- DO NOT SCALE THE DRAWINGS. USE DIMENSIONS SHOWN ON PLAN IN CONJUNCTION WITH THE PLUMBING DOCUMENTS. IF A CONFLICT EXISTS, NOTIFY THE ENGINEER OF RECORD IN WRITING FOR RESOLUTION OF ANY AND ALL CONFLICTS.

SHOP DRAWING SUBMITTALS

- THE REVIEW OF SUBMITTALS AND/ OR SHOP DRAWINGS DONE BY THE STRUCTURAL ENGINEER DOES NOT RELIEVE THE CONTRACTOR OF THE RESPONSIBILITY TO REVIEW AND CHECK SHOP DRAWINGS BEFORE SUBMITTAL TO THE STRUCTURAL ENGINEER. THE REVIEW BY THE STRUCTURAL ENGINEER IS FOR GENERAL CONFORMANCE ONLY. IF SHOP DRAWINGS HAVE NOT BEEN REVIEWED AND APPROVED BEFORE SUBMITTAL TO THE STRUCTURAL ENGINEER, THEY SHALL BE RETURNED WITHOUT APPROVAL.
- THE CONTRACTOR IS SOLELY RESPONSIBLE FOR ANY AND ALL ERRORS AND OMISSIONS ASSOCIATED WITH THE PREPARATION OF ALL SHOP DRAWINGS IN RELATIONSHIP TO THE CONSTRUCTION DOCUMENTS.
- ALL MODIFICATIONS MADE FOR SUBMITTALS THAT ARE RE-SUBMITTED SHALL CLEARLY NOTE ALL CHANGES.
- REPRODUCING THE CONTRACT DOCUMENTS FOR USE AS SHOP DRAWINGS IS NOT ALLOWED, AND SHOP DRAWINGS WILL BE RETURNED WITHOUT APPROVAL.
- GENERAL SHOP DRAWING REQUIREMENTS:
 - SUBMIT SHOP DRAWINGS AND ANY OTHER SPECIAL INFORMATION NECESSARY FOR PROPER FABRICATION, ERECTION, AND PLACEMENT OF STRUCTURAL FABRICATIONS. INCLUDE PLANS, ELEVATIONS, AND SECTIONS. CLEARLY SHOW ANCHORAGES, CONNECTIONS, AND ACCESSORY ITEMS. THE DETAILER MUST INTERPRET THE CONTRACT DOCUMENTS AND CLEARLY CONVEY THIS INTERPRETATION TO THE FIELD IN THE FORM OF PLACING OR ERECTION DRAWINGS.

STRUCTURAL STEEL NOTES

- REFERENCE STANDARDS: STRUCTURAL STEEL SHALL BE DETAILED, FABRICATED AND ERECTED IN ACCORDANCE WITH THE AISC STEEL CONSTRUCTION MANUAL AND THE AISC CODE OF STANDARD PRACTICE (REFERENCED EDITION) WITH EXCEPTION NOTED IN THE PROJECT SPECIFICATIONS.
- OSHA REQUIREMENTS:
 - THE CONTRACTOR SHALL PROVIDE ADDITIONAL ANCHORS, BOLTS, STABILIZERS, STIFFENERS, BRIDGING, BRACING, ETC. AS NECESSARY TO COMPLY WITH CURRENT OSHA REGULATIONS.
 - THE CONTRACTOR SHALL PROVIDE ALL NECESSARY SHORING TO INSURE A STABLE STRUCTURE DURING THE INSTALLATION OF STRUCTURAL STEEL MEMBERS.
- MATERIAL REQUIREMENTS OF STRUCTURAL STEEL SHALL CONFORM TO THE FOLLOWING DESIGNATIONS U.N.O.
 - WIDE FLANGE SHAPES ASTM 992, GRADE 50
 - ANGLES, CHANNELS, AND PLATES ASTM A36 OR ASTM A572, GRADE 50
 - HSS SECTIONS ASTM A500, GRADE "B" (Fy = 46KSI)
 - HIGH STRENGTH BOLTS ASTM A325 OR ASTM A490
 - ANCHOR BOLTS ASTM F1554, GRADE 36 (WELDABLE)
 - WELDING ELECTRODES AWS D1.1 E70
- USE STRUCTURAL STEEL THAT IS FULLY WELDABLE INCLUDING WHEN WELDING BETWEEN DIFFERENT GRADES OF STEEL. SHOP WELDING SHALL BE UTILIZED IN LIEU OF FIELD WELDING WHEN OBTAINABLE.
- ALL SHOP AND FIELD WELDING SHALL CONFORM TO THE STRUCTURAL WELDING CODE AWS D1.1, LATEST EDITION, PUBLISHED BY THE AMERICAN WELDING SOCIETY (AWS). USE ELECTRODES CONFORMING TO AWS D1.1, E70 SERIES, U.N.O. SHOW ALL SHOP WELDS ON THE FABRICATION DRAWINGS AND ALL FIELD WELDS ON THE ERECTION DRAWINGS. WELD SIZES AND LENGTHS ARE SHOWN ON THE DRAWINGS. WELD SIZES ARE THE NET EFFECTIVE SIZE REQUIRED. INCREASE THE WIDTH OF THE WELD IF A GAP EXISTS AT FAYING SURFACES. MINIMUM FILLET WELD SIZE IS 3/16".
- ALL SHOP AND FIELD WELDERS, WELDING OPERATORS, AND TACKERS SHALL BE CERTIFIED ACCORDING TO AWS PROCEDURES AND HAVE EVIDENCE OF PASSING THE AWS STANDARD QUALIFICATION TESTS. CERTIFICATION MUST BE CURRENT.
- ALL JOINT WELDING PROCEDURES TO BE USED SHALL BE PREPARED BY THE FABRICATOR OR CONTRACTOR AS WRITTEN PROCEDURE SPECIFICATIONS AND SUBMITTED TO THE ARCHITECT/ENGINEER FOR THEIR RECORD. ALL JOINT WELDING PROCEDURES SHALL BE QUALIFIED PRIOR TO USE ACCORDING TO AWS PROCEDURES.
- A325 BOLTS:
 - A325 BOLTS SHALL CONFORM TO ASTM A 325 TYPE 1, HIGH STRENGTH BOLTS FOR STRUCTURAL STEEL JOINTS. DO NOT USE TYPE 2 BOLTS.
 - PROVIDE HARDENED WASHERS CONFORMING TO ASTM F 436. PLACE HARDENED WASHERS UNDER PART BEING TURNED.
 - LOAD INDICATOR WASHERS OR TENSION CONTROLLED BOLTS SHALL BE USED ON ALL A325 BOLTS.
 - ALL BOLTS SHALL BE NEW AND DOMESTICALLY MANUFACTURED. DO NOT REUSE BOLTS. USE ONLY NON-GALVANIZED NUTS AND BOLTS THAT ARE CLEAN, RUST-FREE, AND WELL LUBRICATED. BOLTS AND NUTS SHALL BE WAX DIPPED BY THE BOLT SUPPLIER OR LUBRICATED WITH JOHNSON'S STICK WAX 140.
- FIELD MODIFICATION OF STRUCTURAL STEEL SHALL NOT BE CUT IN FIELD OR MODIFIED WITHOUT PRIOR APPROVAL OF THE ENGINEER. SPlicing STEEL MEMBERS IS NOT PERMITTED EXCEPT WHERE EXPLICITLY SHOWN ON THE STRUCTURAL DRAWINGS OR WHERE APPROVED BY THE ENGINEER OF RECORD. SPLICES SHALL NOT OCCUR AT LOCATIONS OF MAXIMUM STRESS AND SHALL DEVELOP THE FULL CAPACITY OF THE MEMBER. SPLICE DETAILS SHALL BE SUBMITTED FOR APPROVAL PRIOR TO BEGINNING WORK.
- WHEN HOLES ARE REQUIRED IN METAL SURFACE, THEY SHALL BE CUT, DRILLED, OR PUNCHED HOLES PERPENDICULAR TO METAL SURFACE. IN NO INSTANCE IS IT ADEQUATE TO USE A FLAME TO CUT OR ENLARGE HOLES IN STRUCTURAL STEEL MEMBERS.
- THE STEEL SUPPLIER SHALL PROVIDE ALL MISCELLANEOUS STRUCTURAL STEEL ITEMS NECESSARY TO FULFILL THE INTENT OF THE STRUCTURAL DRAWINGS WHETHER OR NOT THE ITEMS ARE SHOWN ON THE STRUCTURAL DRAWINGS. SUCH ITEMS MAY INCLUDE BUT ARE NOT LIMITED TO EDGE ANGLES, CLOSURE PLATES, AND DECK SUPPORT FRAMING.
- ALL EXTERIOR EXPOSED STEEL SHALL BE HOT DIP GALVANIZED.
- ALL STRUCTURAL STEEL SHALL BE PRIME PAINTED WITH A MINIMUM DRY FILM THICKNESS OF 2.0 MILS.
- SEE ARCHITECTURAL DRAWINGS FOR ADDITIONAL MISCELLANEOUS STEEL THAT WILL BE REQUIRED.

CHEMICAL ADHESIVE FOR ANCHORAGE

- ADHESIVE ANCHORS SHALL BE AS SPECIFIED ON THE CONSTRUCTION DRAWINGS OR APPROVED EQUIVALENT. ACCEPTABLE SYSTEMS SHALL INCLUDE: SIMPSON, HILTI (EPOXY OR POLYESTER RESIN ADHESIVE) ANCHORS OR APPROVED EQUIVALENT WITH DIAMETER AND EMBEDMENT LENGTH AS NOTED ON THE DRAWINGS OR IN ACCORDANCE WITH THE MANUFACTURERS SPECIFICATIONS. INSTALL ALL ANCHORAGE PER THE MANUFACTURERS RECOMMENDATIONS.
- DIAMETER OF HOLE SHALL BE AS RECOMMENDED BY MANUFACTURER FOR THE PARTICULAR PRODUCT SPECIFIED IN THE DRAWINGS.
- UNLESS NOTED, ANCHOR SPACING AND ANCHOR EDGE DISTANCE SHALL BE ACCORDING TO THE MANUFACTURER'S MOST CURRENT PUBLICATION IN ORDER TO DEVELOP MAXIMUM WORKING LOADS.
- DO NOT EXCEED MANUFACTURER'S MAX. RECOMMENDED TIGHTENING TORQUE.
- ALL ANCHORS SHALL BE INSTALLED AS PER MANUFACTURER'S RECOMMENDATIONS AND UNDER MANUFACTURER'S SUPERVISION IN ORDER TO DEVELOP THE MOST CURRENT PUBLISHED WORKING LOADS.
- INSTALLATION OF ALL ANCHORS SHALL BE PERFORMED BY PERSONNEL CERTIFIED BY AN APPLICABLE CERTIFICATION PROGRAM. CERTIFICATION SHALL INCLUDE WRITTEN AND PERFORMANCE TESTS IN ACCORDANCE WITH ACI/CRSI ADHESIVE ANCHOR INSTALLER CERTIFICATION PROGRAM OR EQUIVALENT.
- ALL ANCHORS INSTALLED SHALL BE CONTINUOUSLY INSPECTED DURING INSTALLATION BY AN INSPECTOR SPECIALLY APPROVED FOR THAT PURPOSE BY THE BUILDING OFFICIAL. THE SPECIAL INSPECTOR SHALL FURNISH A REPORT TO THE LICENSED DESIGN PROFESSIONAL AND BUILDING OFFICIAL THAT THE WORK COVERED BY THE REPORT HAS BEEN PERFORMED AND THE MATERIALS USED AND THE INSTALLATION PROCEDURES USED CONFORM WITH THE APPROVED CONTRACT DOCUMENTS AND THE MANUFACTURER'S PRINTED INSTALLATION INSTRUCTIONS (MPII)
- TESTING OF EPOXIED ANCHORAGE SHALL BE REQUIRED. THE CONTRACTOR SHALL TEST A MINIMUM OF 10% OF EACH DAYS PRODUCTION AND NOT LESS THAN TWO ANCHORS. THE TEST SHALL BE ACCOMPLISHED BY APPLYING A TENSILE LOAD OF 1000 POUNDS TO THE EMBED ANCHOR. IF ANY TEST FAILS THE LOAD TEST ALL APPLICATIONS FOR THAT DAY SHALL BE TESTED. THE TESTING RESULTS SHALL BE REVIEWED BY THE STRUCTURAL ENGINEER.

EPOXY ANCHOR INSTALLATION NOTES

HOLE PREPARATION

- DRILL – DRILL HOLE TO SPECIFIED DIAMETER AND DEPTH.
- BLOW – REMOVE DUST FROM HOLE WITH OIL-FREE COMPRESSED AIR FOR A MINIMUM OF 4 SECONDS. COMPRESSED AIR NOZZLE MUST REACH THE BOTTOM OF THE HOLE.
- BRUSH – CLEAN WITH A NYLON BRUSH FOR A MINIMUM OF 4 CYCLES. BRUSH SHOULD PROVIDE RESISTANCE TO INSERTION. IF NO RESISTANCE IS FELT, THE BRUSH IS WORN AND MUST BE REPLACED.
- BLOW – REMOVE DUST FROM HOLE WITH OIL-FREE COMPRESSED AIR FOR A MINIMUM OF 4 SECONDS. COMPRESSED AIR NOZZLE MUST REACH THE BOTTOM OF THE HOLE.

CARTRIDGE PREPARATION

- CARTRIDGE PREPARATION SHALL INCLUDE CHECKING EXPIRATION DATE ON PRODUCT LABEL. DO NOT USE EXPIRED PRODUCT. PRODUCT IS USABLE UNTIL END OF PRINTED EXPIRATION MONTH.
- ATTACH – ATTACH PROPER NOZZLE TO CARTRIDGE. DO NOT MODIFY NOZZLE.
- INSERT – INSERT CARTRIDGE INTO DISPENSING TOOL.
- DISPENSE – DISPENSE ADHESIVE TO THE SIDE UNTIL PROPERLY MIXED (UNIFORM COLOR).

FILLING THE HOLE

- INSTALL ADHESIVE RETAINING CAP. REFER TO ADHESIVE RETAINING CAPS FOR PROPER ARC SIZE.
- FILL – FILL HOLE 1/2 - 2/3 FULL, STARTING FROM BOTTOM OF HOLE TO PREVENT AIR POCKETS. WITHDRAW NOZZLE AS HOLE FILLS UP.
- INSERT CLEAN, OIL-FREE ANCHOR, TURNING SLOWLY UNTIL THE ANCHOR CONTACTS THE BOTTOM OF THE HOLE.
- DO NOT DISTURB THREADED ROD ANCHOR UNTIL FULLY CURED. (SEE CURE SCHEDULE FOR SPECIFIC ADHESIVE IN CONTRACT DOCUMENTS AND COORDINATE WITH THE MANUFACTURERS WRITTEN INSTRUCTIONS.)

OKALOOSA COUNTY AIRPORTS



AVCON, INC. ENGINEERS & PLANNERS

320 BAYSHORE DRIVE, SUITE A - NICEVILLE, FL 32578-2425
OFFICE: (850) 878-0550, FAX: (850) 678-0240
CORPORATE CERTIFICATE OF AUTHORIZATION NUMBER: 5057
www.avconinc.com



McCarthy ENGINEERING

FL. CA LICENSE NUMBER #29241
214 E. Government St.
Pensacola, Florida 32502
P: (850) 475-1268 F: (850) 502-4210
MEI project: 2017-166

DESTIN-FORT WALTON BEACH AIRPORT

FUEL FARM FALL PROTECTION

GENERAL NOTES

ATTENTION:

THIS DOCUMENT CONTAINS PRIVILEGED AND PROPRIETARY INFORMATION, ALL OF WHICH IS EXPRESSLY PROVIDED BY AVCON, INC., FOR USE BY THE INTENDED RECIPIENT, AND FOR A SPECIFIC PURPOSE. WITHOUT THE EXPRESS WRITTEN CONSENT OF AVCON, INC. ANY DISTRIBUTION, REPRODUCTION, OR OTHER USE OF THIS DOCUMENT, IN WHOLE OR IN PART, IS STRICTLY PROHIBITED.

SCALE:

REVISIONS:

NO.	DATE	BY	DESCRIPTION

100% NOT FOR CONSTRUCTION

DESIGNED BY: DJM
DRAWN BY: WEH
CHECKED BY: DJM
APPROVED BY: DJM
DATE: 8/14/2019

AVCON PROJECT NO. 2017.050.02

SHEET NUMBER

S-001



AVCON, INC.
ENGINEERS & PLANNERS
320 BAYSHORE DRIVE, SUITE A - NICEVILLE, FL 32578-2425
OFFICE: (850) 878-0550, FAX: (850) 678-0340
CORPORATE CERTIFICATE OF AUTHORIZATION NUMBER: 5057
www.avconinc.com



McCarthy
ENGINEERING
FL. CA LICENSE NUMBER #29241
214 E. Government St.
Pensacola, Florida 32502
P: (850) 475-1268 F: (850) 502-4210
MEI project: 2017-166

DESTIN-FORT WALTON BEACH AIRPORT

FUEL FARM FALL PROTECTION

FRAMING PLAN

ATTENTION:
THIS DOCUMENT CONTAINS PRIVILEGED AND PROPRIETARY INFORMATION, ALL OF WHICH IS EXPRESSLY PROVIDED BY AVCON, INC., FOR USE BY THE INTENDED RECIPIENT, AND FOR A SPECIFIC PURPOSE. WITHOUT THE EXPRESS WRITTEN CONSENT OF AVCON, INC. ANY DISTRIBUTION, REPRODUCTION, OR OTHER USE OF THIS DOCUMENT, IN WHOLE OR IN PART, IS STRICTLY PROHIBITED.

SCALE: As indicated

REVISIONS:			
NO.	DATE	BY	DESCRIPTION

100% NOT FOR CONSTRUCTION

DESIGNED BY: DJM
DRAWN BY: WEH
CHECKED BY: DJM
APPROVED BY: DJM
DATE: 8/14/2019

AVCON PROJECT NO. 2017.050.02

SHEET NUMBER

S-100

PLAN NOTES:

1. THE CONTRACTOR SHALL FIELD VERIFY ALL DIMENSIONS PRIOR TO CONSTRUCTION.
2. ALL EXTERIOR STEEL SHALL BE HOT DIP GALVANIZED PRIOR TO INSTALLATION.
3. TANKS 7 & 8, AS BID OPTION 1: IN LIEU OF PROVIDING CATWALK, PROVIDE COST TO INSTALL (4) PAD-EYES FOR INSTALLATION OF HORIZONTAL LIFELINE SYSTEM. THE CONTRACTOR SHALL PROVIDE THE HORIZONTAL LIFE LINE SYSTEM CAPABLE OF RESISTING A 5000 LB POINT LOAD IN ANY DIRECTION.
4. PROVIDE OPENINGS FOR PENETRATIONS AS REQUIRED. FIELD FIT AND CUT ANGLES AS REQUIRED. AFTER MODIFYING ANGLES, COLD GALVANIZE ANY EXPOSED END.
5. FOR ALL NEW CATWALKS, PROVIDE McNICHOLS FIBERGLASS GRATING PULTRUDED, I-BAR, MS-16015 - DURAGRID, SPF POLYESTER RESIN, GRAY, 1.5" HEIGHT.
6. ALL NEW COLUMNS SHALL BE HSS4X4X1/4 U.N.O.

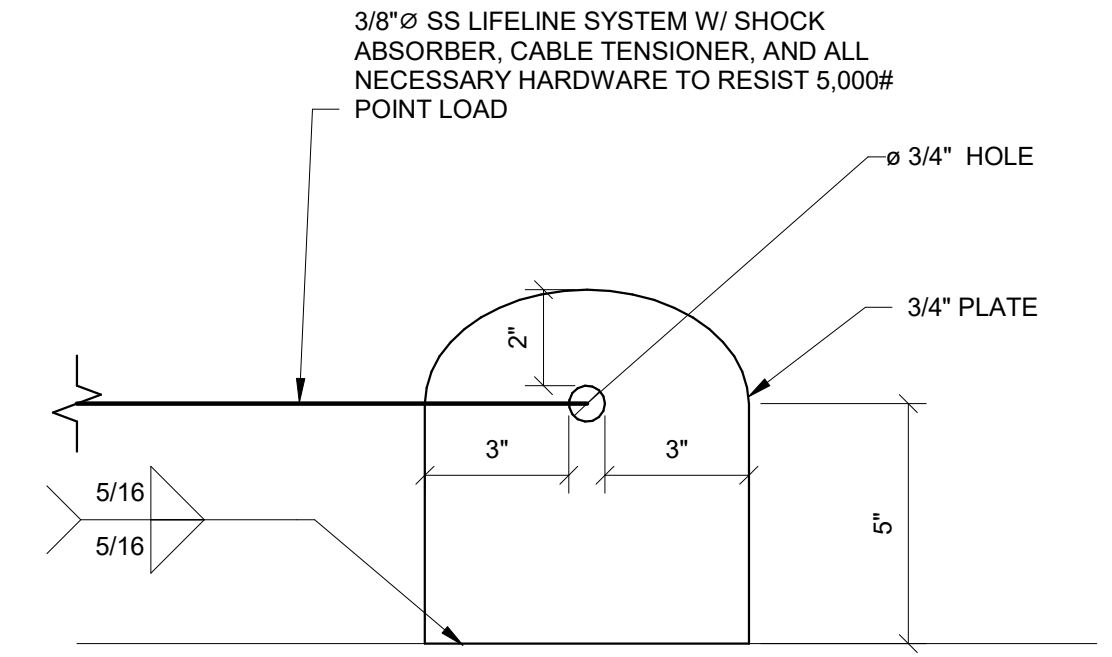
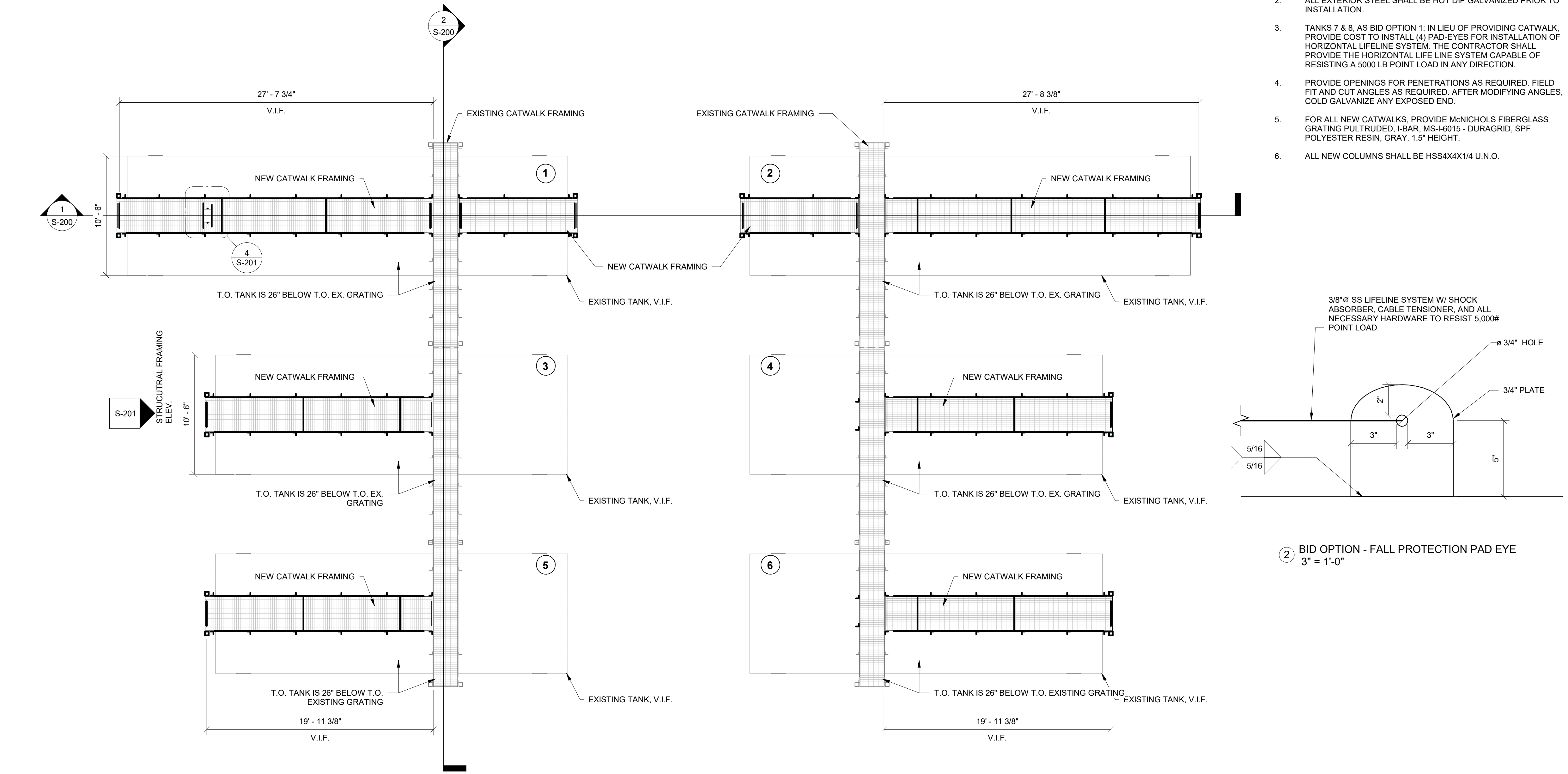

2 BID OPTION - FALL PROTECTION PAD EYE
3" = 1'-0"

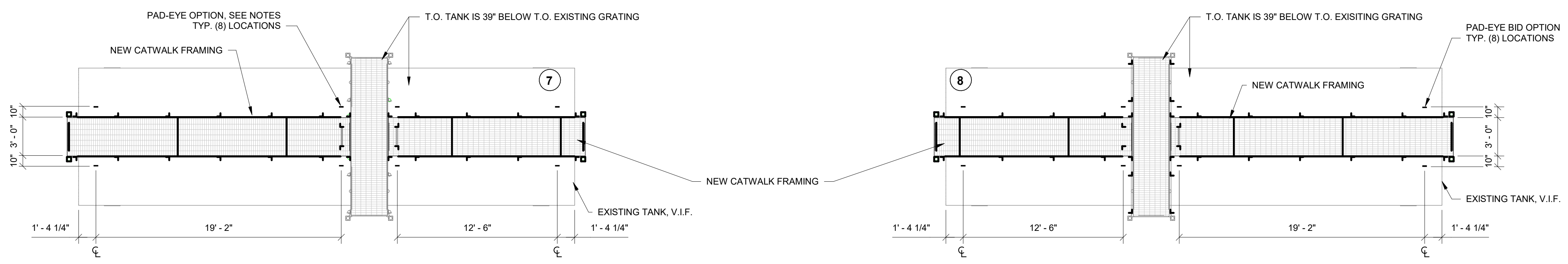

1 CATWALK FRAMING PLAN
3/16" = 1'-0"

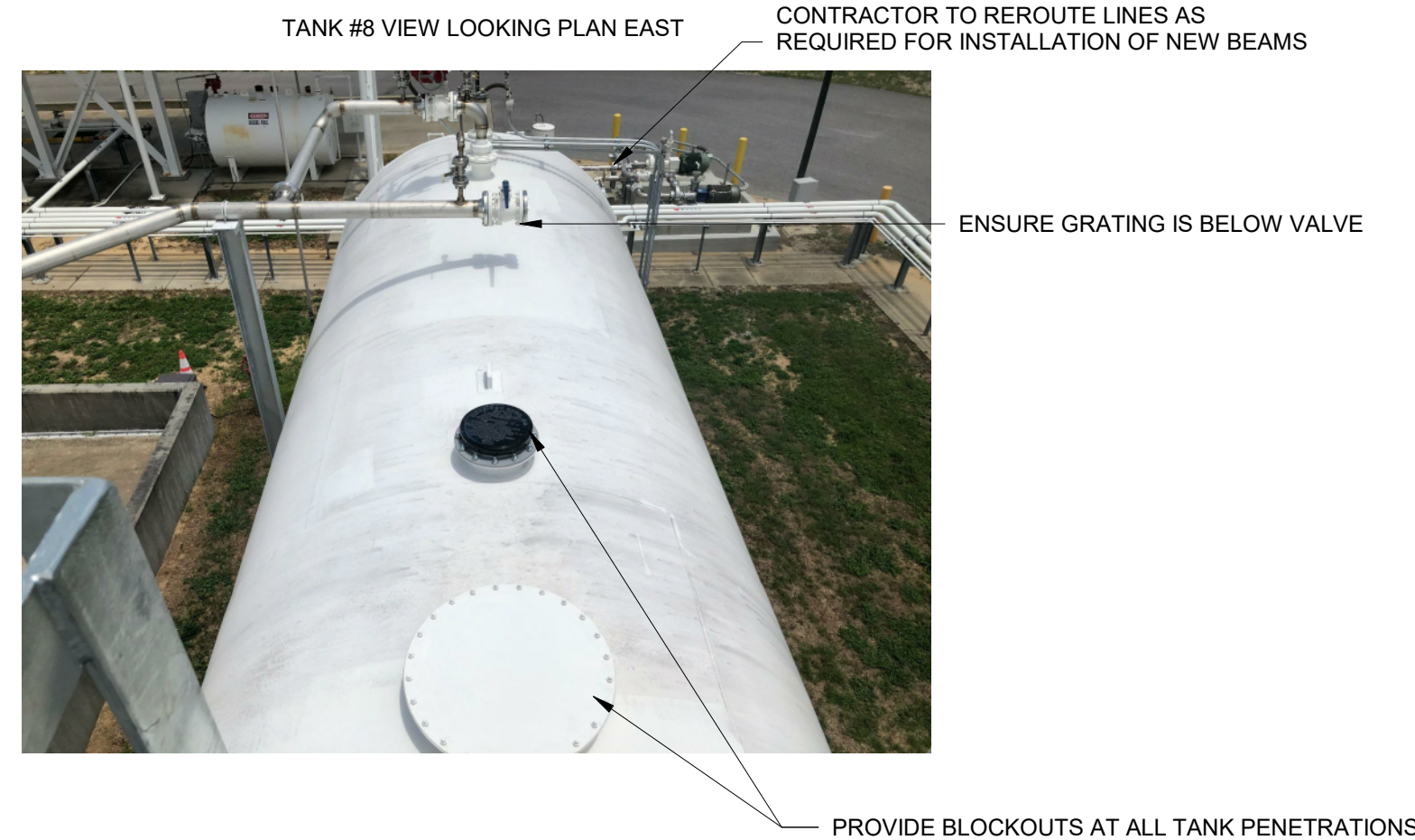

1 TANK #8 PLAN EAST VIEW
3/4" = 1'-0"



2 TANK #8 PLAN WEST VIEW
3/4" = 1'-0"



3 TANK #7 PLAN WEST VIEW
3/4" = 1'-0"



4 TANK #7 PLAN EAST VIEW
3/4" = 1'-0"



5 TANKS #1, #3, #5 PLAN WEST VIEW
3/4" = 1'-0"



6 TANK #2 PLAN WEST VIEW
3/4" = 1'-0"



7 TANK #1 PLAN EAST VIEW
3/4" = 1'-0"



AVCON, INC.
ENGINEERS & PLANNERS
320 BAYSHORE DRIVE, SUITE A - NICEVILLE, FL 32578-2425
OFFICE: (850) 878-0550 FAX: (850) 678-0340
CORPORATE CERTIFICATE OF AUTHORIZATION NUMBER: 5057
www.avconinc.com



McCarthy
ENGINEERING
FL. CA LICENSE NUMBER #29241
214 E. Government St.
Pensacola, Florida 32502
P: (850) 475-1268 F: (850) 502-4210
MEI project: 2017-166

DESTIN-FORT WALTON BEACH AIRPORT

FUEL FARM FALL PROTECTION

STRUCTURAL INFORMATION

ATTENTION:
THIS DOCUMENT CONTAINS PRIVILEGED AND PROPRIETARY INFORMATION, ALL OF WHICH IS EXPRESSLY PROVIDED BY AVCON, INC., FOR USE BY THE INTENDED RECIPIENT, AND FOR A SPECIFIC PURPOSE. WITHOUT THE EXPRESS WRITTEN CONSENT OF AVCON, INC. ANY DISTRIBUTION, REPRODUCTION, OR OTHER USE OF THIS DOCUMENT, IN WHOLE OR IN PART, IS STRICTLY PROHIBITED.

SCALE: 3/4" = 1'-0"

REVISIONS:

NO.	DATE	BY	DESCRIPTION

100% NOT FOR CONSTRUCTION

DESIGNED BY: Designer
DRAWN BY: Author
CHECKED BY: Checker
APPROVED BY: Approver
DATE: 8/14/2019

AVCON PROJECT NO. 2017.050.02

SHEET NUMBER
S-101

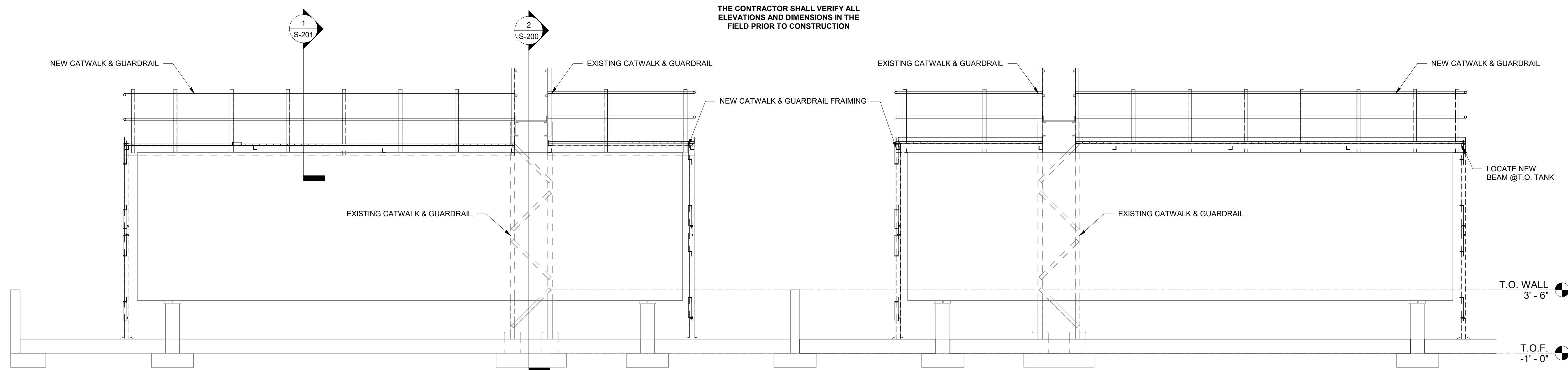

1 Section 1
1/4" = 1'-0"

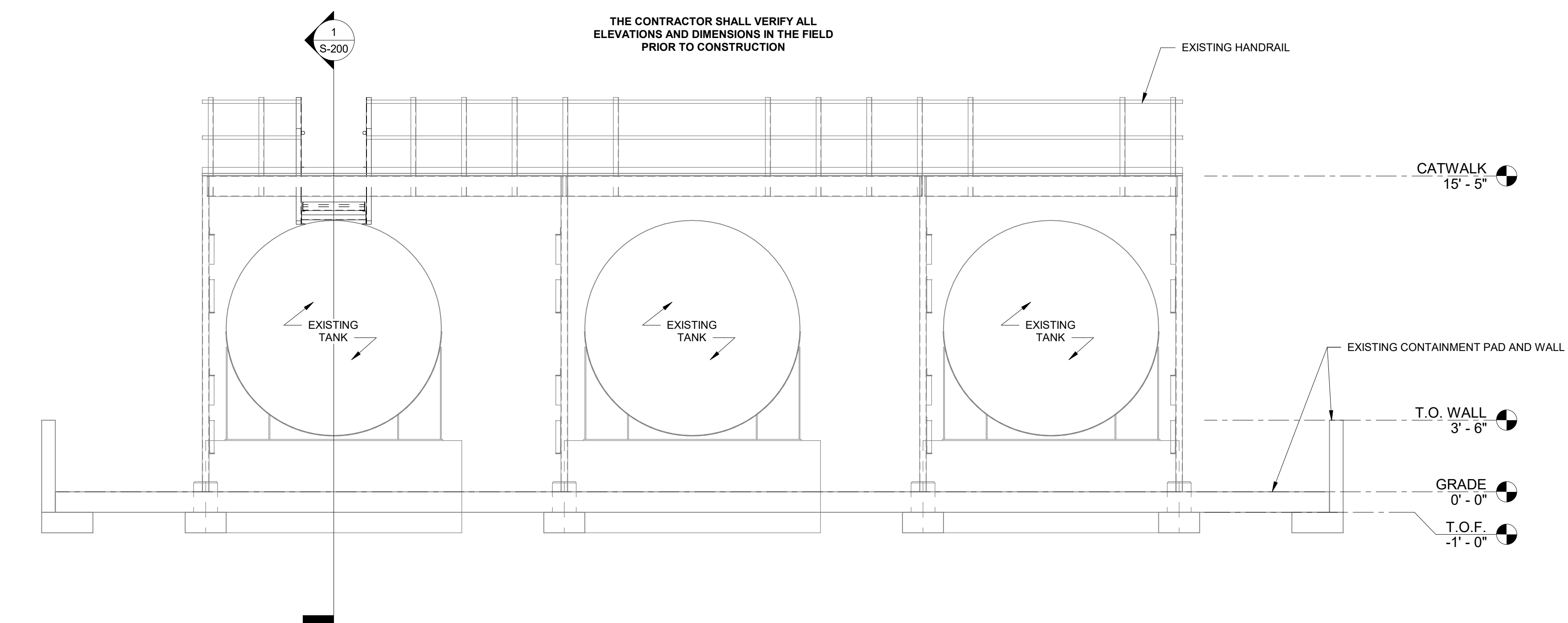

2 Section 2
1/4" = 1'-0"

OKALOOSA COUNTY AIRPORTS



AVCON, INC.
ENGINEERS & PLANNERS
320 BAYSHORE DRIVE, SUITE A - NICEVILLE, FL 32578-2425
OFFICE: (850) 878-0050 - FAX: (850) 678-0040
CORPORATE CERTIFICATE OF AUTHORIZATION NUMBER: 5057
www.avconinc.com



McCarthy
ENGINEERING
FL. CA LICENSE NUMBER #29241
214 E. Government St.
Pensacola, Florida 32502
P: (850) 475-1268 F: (850) 502-4210
MEI project: 2017-166

DESTIN-FORT
WALTON BEACH
AIRPORT

FUEL FARM FALL
PROTECTION

STRUCTURAL SECTIONS

ATTENTION:
THIS DOCUMENT CONTAINS PRIVILEGED AND PROPRIETARY INFORMATION, ALL OF WHICH IS EXPRESSLY PROVIDED BY AVCON, INC., FOR USE BY THE INTENDED RECIPIENT, AND FOR A SPECIFIC PURPOSE. WITHOUT THE EXPRESS WRITTEN CONSENT OF AVCON, INC. ANY DISTRIBUTION, REPRODUCTION, OR OTHER USE OF THIS DOCUMENT, IN WHOLE OR IN PART, IS STRICTLY PROHIBITED.

SCALE: 1/4" = 1'-0"

REVISIONS:			
NO.	DATE	BY	DESCRIPTION

100% NOT FOR CONSTRUCTION

DESIGNED BY: DJM
DRAWN BY: WEH
CHECKED BY: DJM
APPROVED BY: DJM
DATE: 8/14/2019

AVCON PROJECT NO. 2017.050.02

SHEET NUMBER

S-200

THE CONTRACTOR SHALL VERIFY ALL ELEVATIONS AND DIMENSIONS IN THE FIELD PRIOR TO CONSTRUCTION

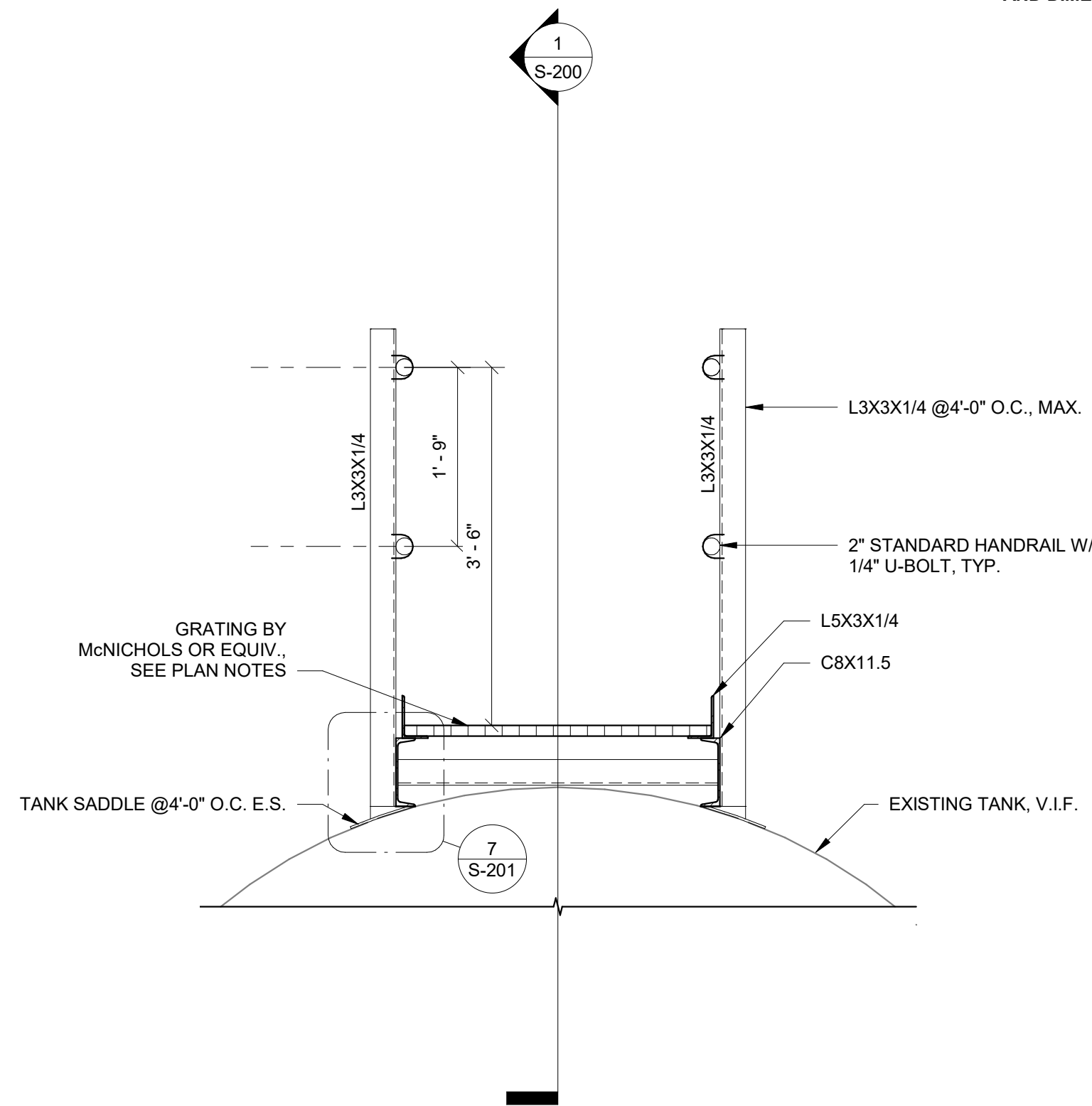

1 SECTION THRU CATWALK
3/4" = 1'-0"

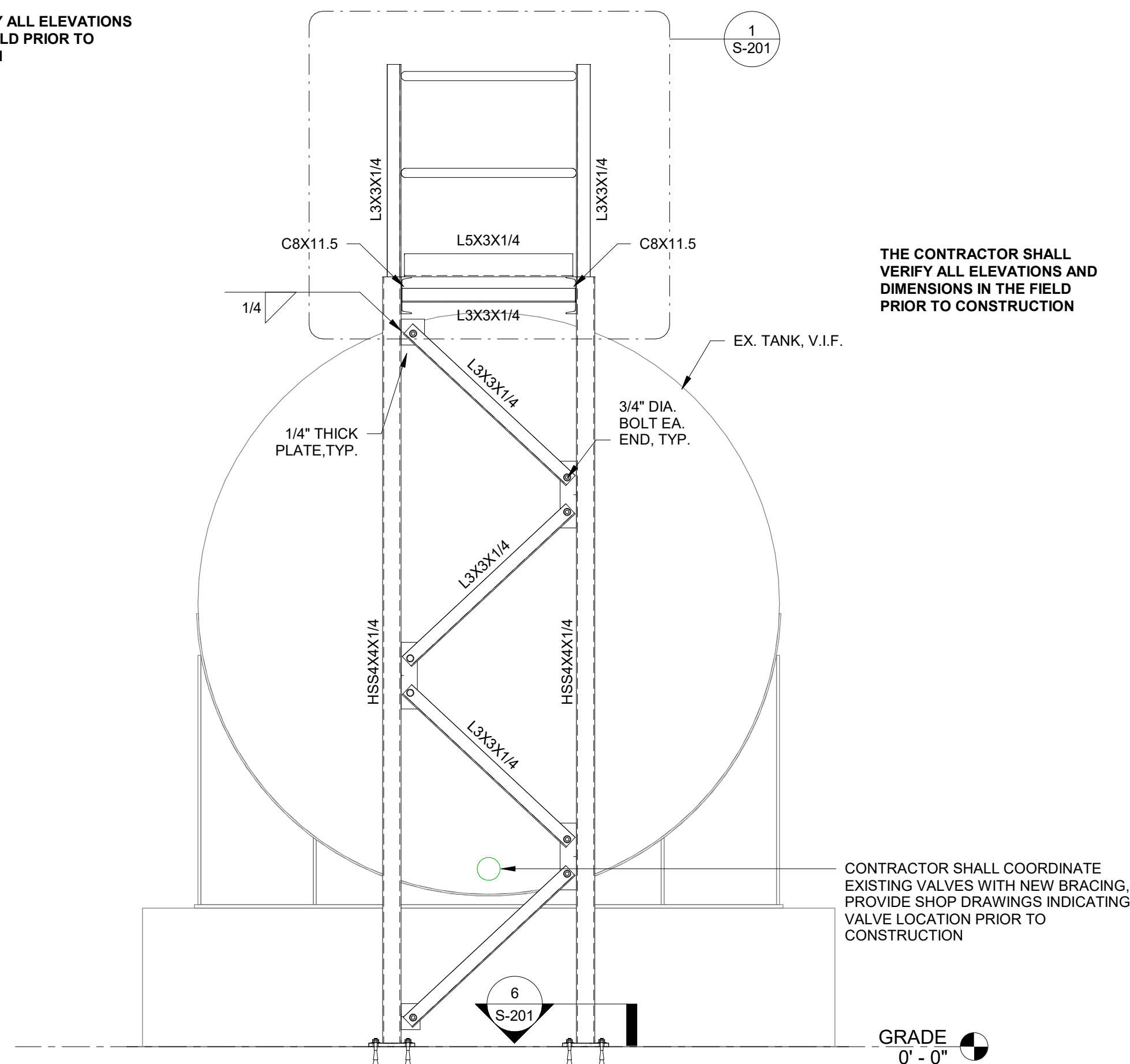

2 STRUCTURAL FRAMING ELEV.
1/2" = 1'-0"

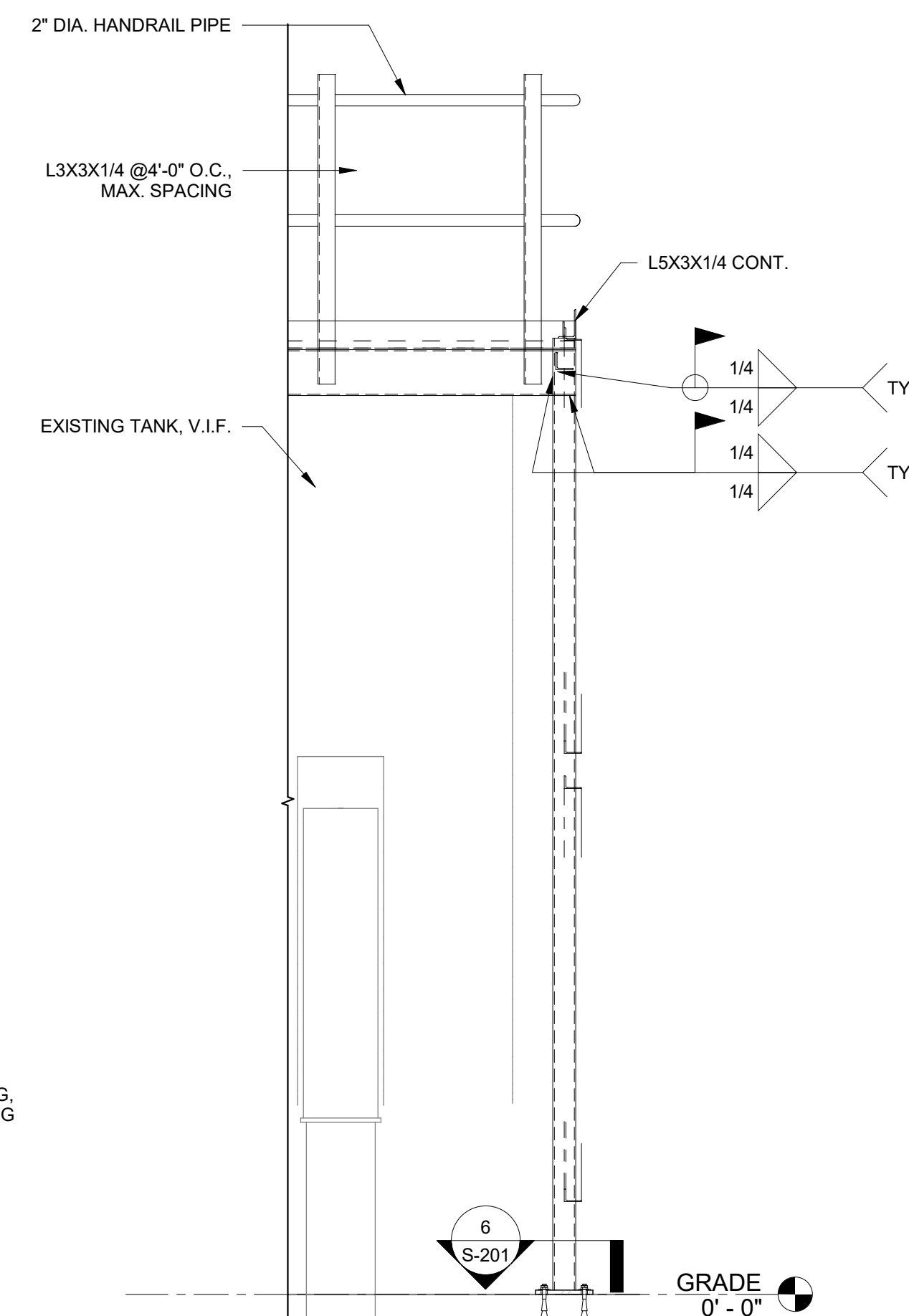

3 SECTION AT CATWALK
1/2" = 1'-0"

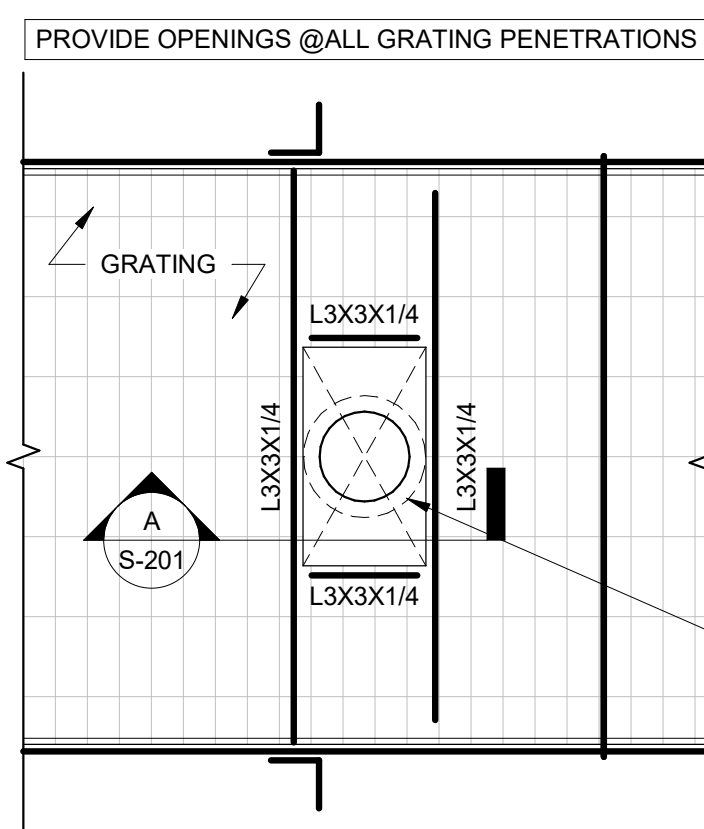

4 GRATING OPENING DETAIL
1" = 1'-0"

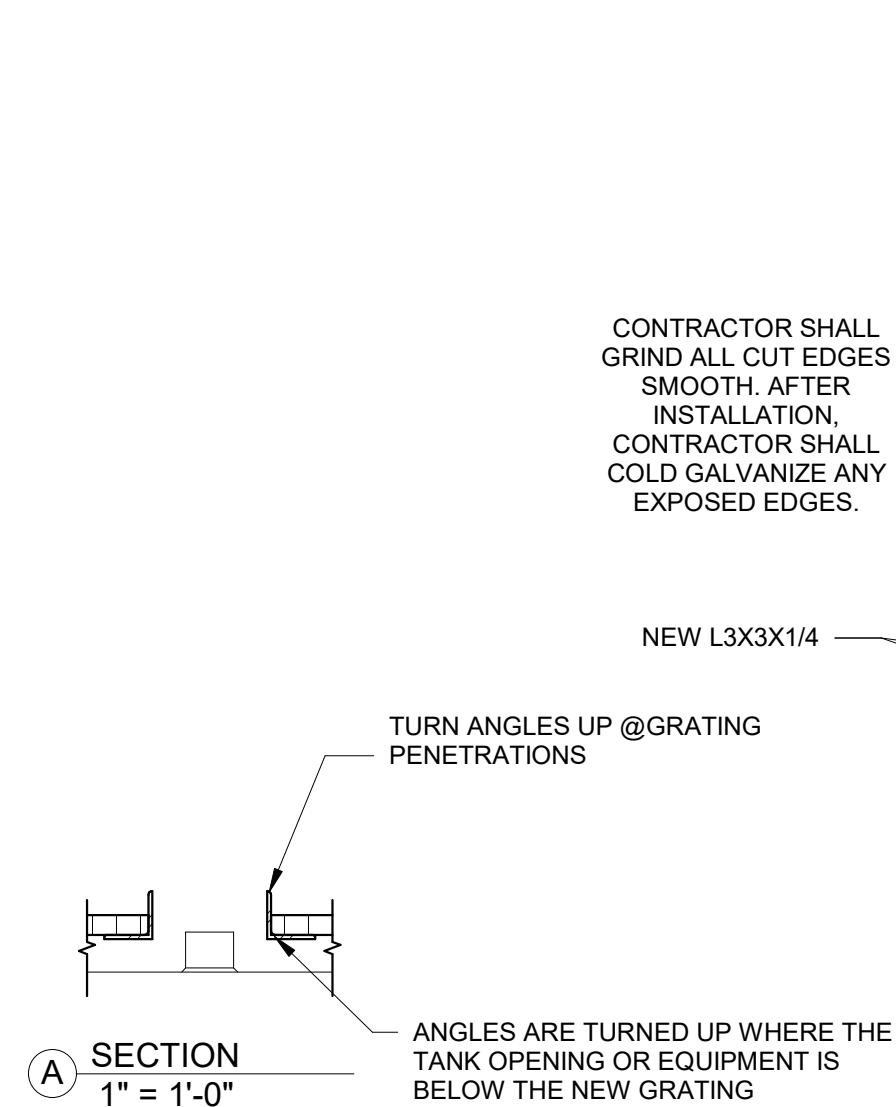

5 NEW CATWALK ATTACHMENT DETAIL
1 1/2" = 1'-0"

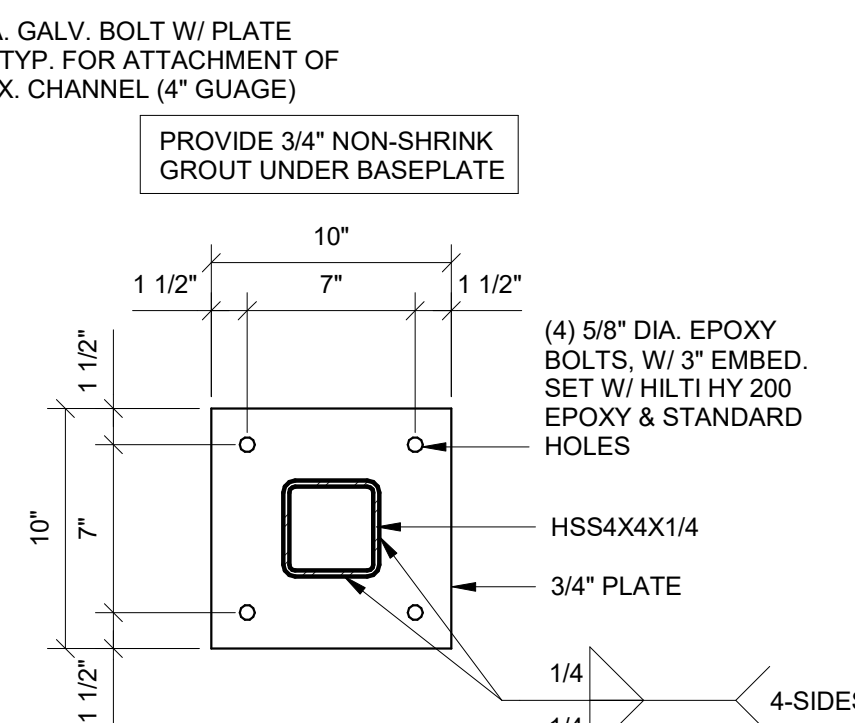

6 HSS4X4X1/4 BASEPLATE
1 1/2" = 1'-0"

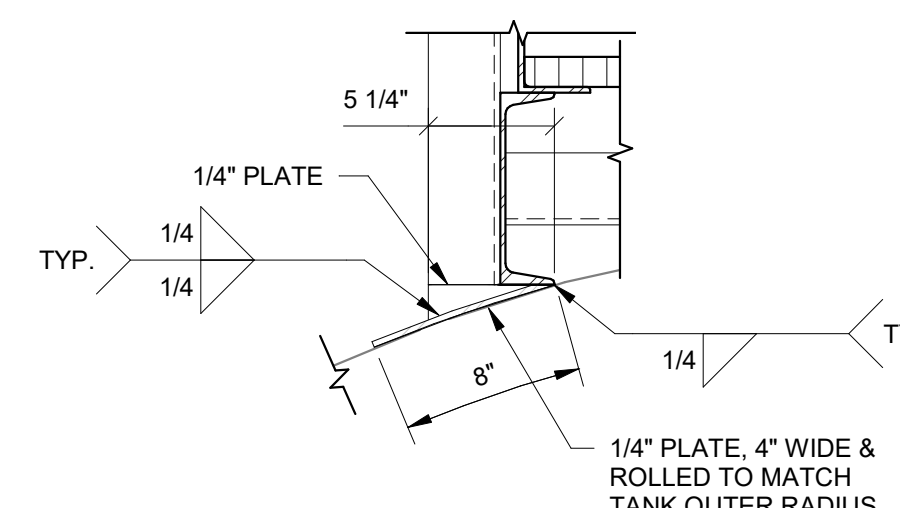

7 TANK SADDLE DETAIL
1 1/2" = 1'-0"

THE CONTRACTOR SHALL VERIFY ALL ELEVATIONS AND DIMENSIONS IN THE FIELD PRIOR TO CONSTRUCTION

CONTRACTOR SHALL COORDINATE EXISTING VALVES WITH NEW BRACING. PROVIDE SHOP DRAWINGS INDICATING VALVE LOCATION PRIOR TO CONSTRUCTION



AVCON, INC.
ENGINEERS & PLANNERS
320 BAYSHORE DRIVE, SUITE A - NICEVILLE, FL 32578-2425
OFFICE: (850) 878-0550 FAX: (850) 678-0340
CORPORATE CERTIFICATE OF AUTHORIZATION NUMBER: 5057
www.avconinc.com



McCarthy
ENGINEERING
FL. CA LICENSE NUMBER #29241
214 E. Government St.
Pensacola, Florida 32502
P: (850) 475-1268 F: (850) 502-4210
MEI project: 2017-166

DESTIN-FORT
WALTON BEACH
AIRPORT

FUEL FARM FALL
PROTECTION

STRUCTURAL DETAILS

ATTENTION:
THIS DOCUMENT CONTAINS PRIVILEGED AND PROPRIETARY INFORMATION, ALL OF WHICH IS EXPRESSLY PROVIDED BY AVCON, INC., FOR USE BY THE INTENDED RECIPIENT, AND FOR A SPECIFIC PURPOSE. WITHOUT THE EXPRESS WRITTEN CONSENT OF AVCON, INC., ANY DISTRIBUTION, REPRODUCTION, OR OTHER USE OF THIS DOCUMENT, IN WHOLE OR IN PART, IS STRICTLY PROHIBITED.

SCALE: As indicated

REVISIONS:			
NO.	DATE	BY	DESCRIPTION

100% NOT FOR CONSTRUCTION

DESIGNED BY: DJM
DRAWN BY: WEH
CHECKED BY: DJM
APPROVED BY: DJM
DATE: 8/14/2019

AVCON PROJECT NO. 2017.050.02

SHEET NUMBER

S-201